

# ORIGINAL

## BEFORE THE ILLINOIS POLLUTION CONTROL BOARD

IN THE MATTER OF: )  
 )  
 PROPOSED AMENDMENTS TO )  
 EXEMPTIONS FROM STATE )  
 PERMITTING REQUIREMENTS )  
 FOR PLASTIC INJECTION MOLDING )  
 OPERATIONS )  
 (35 Ill. Admin. Code 201.146) )

R 05-20

**RECEIVED**  
 CLERK'S OFFICE  
 JUN 16 2005  
 STATE OF ILLINOIS  
 Pollution Control Board

### NOTICE OF FILING

TO: Ms. Dorothy M. Gunn  
 Clerk of the Board  
 Illinois Pollution Control Board  
 100 West Randolph Street  
 Suite 11-500  
 Chicago, Illinois 60601  
**(VIA HAND DELIVERY)**

(PERSONS ON ATTACHED SERVICE LIST)

PLEASE TAKE NOTICE that on June 16, 2005, I filed with the Office of the Clerk of the Illinois Pollution Control Board an original and nine copies each of 1) PREFILED TESTIMONY OF LISA FREDE ON BEHALF OF THE CHEMICAL INDUSTRY COUNCIL OF ILLINOIS; 2) PREFILED TESTIMONY OF LYNNE R. HARRIS ON BEHALF OF THE SOCIETY OF THE PLASTICS INDUSTRY, INC., and 3) PREFILED TESTIMONY OF PATRICIA F. SHARKEY ON BEHALF OF THE CHEMICAL INDUSTRY COUNCIL OF ILLINOIS, copies of which are hereby served upon you.

Dated: June 16, 2005

Respectfully submitted,

CHEMICAL INDUSTRY COUNCIL OF ILLINOIS

By: \_\_\_\_\_

One of its Attorneys

Patricia F. Sharkey  
 Mayer, Brown, Rowe & Maw LLP  
 190 South LaSalle Street  
 Chicago, Illinois 60603-3441  
 (312) 782-0600

ORIGINAL

RECEIVED  
CLERK'S OFFICE

JUN 16 2005

CERTIFICATE OF SERVICE

STATE OF ILLINOIS  
Pollution Control Board

I, Patricia F. Sharkey, an attorney, hereby certify that I have served the following documents: 1) Prefiled Testimony of Lisa Frede on Behalf of the Chemical Industry Council of Illinois; 2) Prefiled Testimony of Lynne R. Harris on Behalf of The Society of the Plastics Industry, Inc. and 3) Prefiled Testimony of Patricia F. Sharkey on Behalf of the Chemical Industry Council of Illinois upon:

Ms. Dorothy M. Gunn  
Clerk of the Board  
Illinois Pollution Control Board  
100 West Randolph Street  
Suite 11-500  
Chicago, Illinois 60601  
(Hand Delivery)

Charles E. Matoesian  
Division of Legal Counsel  
Illinois Environmental Protection Agency  
1021 North Grand Avenue East  
Post Office Box 19276  
Springfield, Illinois 62794-9276  
(U.S. Mail and E-Mail)

Matthew Dunn, Chief  
Division of Environmental Enforcement  
Office of the Attorney General  
188 West Randolph Street, 20<sup>th</sup> Floor  
Chicago, Illinois 60601  
(U.S. Mail)

Office of Legal Services  
Illinois Department of Natural Resources  
One Natural Resources Way  
Springfield, Illinois 62702-1271  
(U.S. Mail)

Donald Sutton  
Manager, Permit Section  
Division of Air Pollution  
Bureau of Air  
Illinois Environmental Protection Agency  
1021 North Grand Avenue East  
Post Office Box 19276  
Springfield, Illinois 62794-9276  
(U.S. Mail)

as indicated above, by delivery, e-mail and/or by depositing said documents in the United States Mail, postage prepaid, in Chicago, Illinois on June 16, 2005.

  
\_\_\_\_\_  
Patricia F. Sharkey

Patricia F. Sharkey  
Mayer, Brown, Rowe & Maw LLP  
190 South LaSalle Street  
Chicago, Illinois 60603-3441  
(312) 782-0600

BEFORE THE ILLINOIS POLLUTION CONTROL BOARD

IN THE MATTER OF:

PROPOSED AMENDMENTS TO )  
EXEMPTIONS FROM STATE )  
PERMITTING REQUIREMENTS )  
FOR PLASTIC INJECTION MOLDING )  
OPERATIONS )  
(35 Ill. Admin. Code 201.146) )

ORIGINAL

RECEIVED  
CLERK'S OFFICE

JUN 16 2005

STATE OF ILLINOIS  
Pollution Control Board

R 05 -20

**PRE-FILED TESTIMONY OF LISA FREDE  
ON BEHALF OF THE  
CHEMICAL INDUSTRY COUNCIL OF ILLINOIS**

My name is Lisa Frede, and I am the Director of Regulatory Affairs for the Chemical Industry Council of Illinois ("CICI"), a not-for-profit Illinois corporation. CICI is pleased to be the proponent of the rulemaking proposal in this proceeding.

I would like to begin by giving you an overview of CICI and its membership and then briefly discuss the significance of this proposed rulemaking to our members.

CICI is a statewide trade association representing the chemical industry in Illinois. CICI has offices in Des Plaines and Springfield, Illinois. We have 198 member companies with over 54, 000 employees employed in 745 manufacturing facilities and 975 wholesale and distribution facilities in Illinois.

One of CICI's functions is to represent its member companies in the formation of public policies and programs which are mutually beneficial to the citizens of Illinois and the chemical industry. In this capacity, CICI monitors statewide legislation and regulations in Illinois, including environmental permitting programs, and provides information and makes recommendations to its membership. CICI also often advocates on behalf of its membership for more cost effective and efficient regulatory requirements.

Chemical manufacturers in Illinois produce a wide array of products from plastics, pesticides and industrial chemicals to lifesaving medicines and household products. Workers directly employed in the chemical industry represent 7.3% of the state's manufacturing work force and have an average wage over \$60,000 per year. The chemical industry generates an additional 296,000 jobs in Illinois at industry suppliers, manufacturers, transporters, trade and business services companies, and construction companies.

The proposal in this proceeding will amend the Board's regulations governing state air pollution control permits to exempt plastic injection molding operations from the state construction and operation permitting procedures. CICI is proposing this amendment to clarify the Board's regulations and achieve efficiencies and cost savings for its plastic injection molding company members in Illinois and for the State permitting program.

As will be discussed by another witness in this proceeding, the emissions from plastic injection molding machines are extremely low – on the order of a few tenths of a ton of volatile organic emissions per year. This is on the order of – and in fact less than – the 0.1 lb/ hour or 0.44 tons per year that defines an “insignificant activity” under the Board's major source regulations at 35 Ill. Adm. Code 201.210 (a)(2) and(3).

These emission levels are also on the order of – or less than – the emissions recognized to be associated with other categories of emission sources that are currently exempt from state permitting under Section 201.146. In fact, the emission factors accepted by Illinois EPA and other regulators across the country for determining emissions from plastic injection molding operations are the same as those that are used

for plastic extrusion – a process which is exempted from Illinois state permitting in Section 201.146(cc) and defined as an “insignificant activity” in Section 201.210(a)(5). While many owners and operators believe that “plastic injection molding” is a form of extrusion covered under the existing categorical exemption, the adoption of the specific language proposed in this rulemaking is designed to resolve any question.

Here’s what this amendment will do:

- It will appropriately regulate the insignificant level of emissions generated by plastic injection molding operations by treating those operations in the same fashion as other operations with similarly low levels of emissions.
- It will reduce unwarranted permitting costs to plastic injection molding businesses across Illinois.
- It will also relieve owners and operators of plastic injection molding operations from the risk of enforcement actions based upon differences in interpretation of existing categorical exemptions.
- Finally, it will allow Illinois EPA to allocate its permitting and enforcement resources to more significant emission sources.

What this amendment will not do:

- It will not relieve affected emission units from any applicable requirement other than state construction and operating permitting. Thus, for example, a plastic injection molder – like any other exempt emission source under Section 201.146 – remains subject to the generic volatile organic matter emissions limit of 8 lb/hour found in the Board’s rules at 35 Ill. Admin. Code 215.301.
- It will not result in an increase in emissions and will not have an impact on air quality in Illinois. Because this is only an exemption from procedural requirements, it will not affect emissions to the environment.

Prior to proposing this regulatory amendment, CICI’s Executive Director, Mark Biel, had several discussions with Don Sutton, the Manager of the Illinois EPA Permit Section, about adding a categorical exemption to the list of existing categorical exemptions in 35 Ill. Admin. Code § 201.146 for plastic injection molding and associated resin handling and storage activities. Mr. Sutton agreed that this is a category of

insignificant emission sources for which a permit exemption is consistent with other categorical exemptions in Section 201.146. He also agreed that relieving the State of the burden of permitting these insignificant sources would be beneficial to the State.

CICI believes that reducing the permitting burden on the Agency is in the interest of its members. Agency resources should be focused on significant emission sources. In the pending rulemaking proceeding, R05-19, Mr. Sutton testified that the Agency still hasn't issued 30 of the Title V major source permits that were due to be issued back in 1997. Transcript, pp. 29-30, April 12, 2005 Hearing, IPCB Docket R05-19. In addition, CICI is aware that many of its members have Title V permit renewals and permit revisions that have been pending before the Agency for several years. Mr. Sutton testified that while IEPA issues roughly 1,900 air permits a year, it has at any time a backlog of 900 to 1,000 permit applications. *Id.*, p. 31. Yet the Agency is required to spend its resources on a host of construction and operating permits for very minor emission sources. The transcript of the R05-19 April 12, 2005 hearing reveals that 70% of the Agency's construction permits are issued for modifications involving no emission increase or increases of less than 1 ton. *Id.* p. 12. At the same time, 95% of the actual emissions emitted in Illinois are emitted by the top 15% of the State's major sources. *Id.* p. 53. Permitting very small emission sources, while large emission source applications are backlogged isn't a good use of tax dollars, it isn't good for the environment, and it isn't good for regulated businesses.

That burden will be significantly reduced when the rulemaking in R05-19 is adopted. However, because that rulemaking only exempts insignificant emission sources at *facilities with other significant or non-exempt emission sources*, it does not relieve the

Agency from permitting a plastic injection molding facility that has no other emission sources. This is an anomaly with no rationale in terms of emissions or the environment when it comes to plastic injection molding. Given the limitation in the proposal in R05-19, the adoption of a clear categorical exemption for plastic injection molding operations in this rulemaking proceeding will harmonize the Board's regulatory approach for a category recognized by all to emit at levels that do not warrant separate state permitting.

CICI would like to thank the Board for its consideration of this proposal, and I would be happy to answer any questions you may have.

Date: 6/16/05

Respectfully submitted,

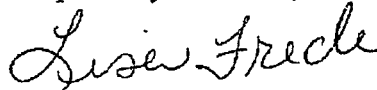

Lisa Frede

Director of Regulatory Affairs  
Chemical Industry Council of Illinois

ORIGINAL

BEFORE THE ILLINOIS POLLUTION CONTROL BOARD

RECEIVED  
CLERK'S OFFICE

JUN 16 2005

STATE OF ILLINOIS  
Pollution Control Board

IN THE MATTER OF: )  
)  
PROPOSED AMENDMENTS TO )  
EXEMPTIONS FROM STATE )  
PERMITTING REQUIREMENTS )  
FOR PLASTIC INJECTION MOLDING )  
OPERATIONS )  
(35 Ill. Admin. Code 201.146) )

R 05 -20

**PRE-FILED TESTIMONY OF LYNNE R. HARRIS  
ON BEHALF OF THE  
SOCIETY OF THE PLASTICS INDUSTRY, INC.**

My name is Lynne R. Harris, and I am the Vice President, Science and Technology, for The Society of the Plastics Industry, Inc. ("SPI"), a not-for-profit 501(c)6 trade association headquartered in Washington D.C., predominantly serving members across the United States. I have been employed by SPI for over 14 years. My current work focuses on science and technology, environment, health and safety, and codes and standards for the plastics industry. My educational background includes a Bachelor of Science and Masters of Engineering in chemical engineering. My publications include co-authorship on a paper for the development of emission factors for the extrusion processing of polyethylene resin.<sup>1</sup> I have worked in and around the plastics industry for over 25 years.

I have been asked by the Chemical Industry Council of Illinois (CICI) to provide an overview of the plastics injection molding industry, a description of the plastic injection molding process, and a discussion of the types and volumes of emissions generated during the plastic injection molding process for various resins.



### **The Society of the Plastics Industry: Who Are We?**

Let me begin by describing SPI and the work it performs on behalf of its members. Founded in 1937, The Society of the Plastics Industry, Inc., is the trade association representing one of the largest manufacturing industries in the United States. SPI's members represent the entire plastics industry supply chain, including processors, machinery and equipment manufacturers and raw materials suppliers. The U.S. plastics industry employs 1.4 million workers and provides more than \$310 billion in annual shipments. SPI represents the entire plastics industry and has more than 1000 members. SPI has been involved in the development of state and federal environmental regulations affecting the plastics industry for decades. As I will be discussing, SPI has also coordinated a number studies of emissions generated by the extrusion processing of thermoplastics.

### **Background on the Plastic Injection Molding Industry**

My testimony today is focused on plastic injection molding ("PIM"), a category of plastic product manufacturing. There are over 7,700 PIM facilities in the United States and approximately 500 operating in Illinois.<sup>2,3</sup> These facilities range in size from small facilities with a few machines and less than 20 employees to larger facilities with dozens of machines employing over a hundred employees.<sup>2,4</sup> The trade publication *Plastics News* surveys the PIM industry annually and publishes an annual listing of over 600 PIM companies in North America. That listing indicates the top PIM companies responding to the survey with annual sales ranging from approximately \$100,000 to \$1.5 billion, with median annual sales on the order of \$10 million. The components produced in PIM processes are generally small plastic components used in a multitude of products. For

example, PIM products include knobs and handles used in the automotive industry and hole plugs used in household appliances. PIM products tend to be molded to meet specific needs in customized molds and made with resins meeting the temperature, strength and durability specifications required for a specific use. As a result, PIM machines are generally dedicated to molding specific component parts and cannot be used to produce other parts without physical modification of the equipment.

### **Description of PIM Equipment and Process**

The PIM process essentially involves forcing molten plastic into a mold cavity. This takes place in several steps. A diagram of a standard PIM machine, attached to my pre-filed testimony, depicts the components of the PIM process. *Exhibit 1*. As can be seen from that diagram, the essential components are a hopper from which pelletized resin is fed into the extruder screw, a heated extruder barrel which melts the resin as it is advanced by the extruder screw under pressure, and a die head through which the molten resin is injected into a mold cavity.

Note that the fundamental piece of equipment involved in this process is a heated screw extruder. The equipment that is required to extrude resin into molds in the PIM process is the same as that which is required to extrude resin into a continuous strand except that the resin is injected into an enclosed mold at the end of the process rather than simply conforming to the shape of the extrusion die. A PIM machine is essentially a non-continuous extruder. As I will discuss later, this is why the emission factors developed for extrusion processes are appropriate for the PIM process.

Plastic injection molding machines, like other types of extruders, vary in size. A small PIM machine may have a throughput of 10 pounds per hour, while a large machine

may process as much as 200 pounds per hour. These numbers are derived based on a typical injection capacity of 4 to 100 ounces and typical tonnage of 50 to 600 tons. Injection capacity can go to around 400 ounces and tonnage can go up to around 10,000 tons.<sup>5</sup> These data are consistent with product information compiled from several equipment manufacturers, as illustrated in *Exhibit 2*. Very large PIM machines can process over 1,000 pounds per hour. PIM machines of all sizes are in use in Illinois and across the United States. However, the most commonly used machines in the PIM industry have an average daily throughput of less than 100 pounds per hour.

The five most commonly used plastic resins in the PIM industry according to the 2005 survey of North American injection molders by *Plastics News*<sup>2</sup> are polypropylene (PP), acrylonitrile butadiene styrene (ABS), polycarbonate (PC), high density polyethylene (HDPE) and nylon (polyamide, PA).

#### **Emissions from Extrusion Processes**

Until 1995, little quantitative information was publicly available regarding emissions from thermoplastic extrusion processes. While it was assumed that any volatile organic, particulate or hazardous air emissions were very low, emission factors simply did not exist. To fill this gap, SPI sponsored a number of studies published between 1995 and 2002 to develop emission factors for a range of plastic resins. The studies were intended to provide emission factors for processors who needed Title V permits under the US Environmental Protection Agency Clean Air Act Amendments of 1990.

The SPI-sponsored studies were conducted at an independent testing laboratory operated by Battelle in Columbus, Ohio. Studies were conducted using a strand extruder with a 1.5-inch single screw and fitted with an eight-strand die for commonly used resins.

Resins with basic additives were provided by a number of suppliers and tested as aggregates; the resins tested were PP, PC, PE, PA and ethylene-vinyl acetate and ethylene-methyl acrylate copolymer (EVA/EMA).

The extruder system was chosen as the process likely to overestimate emissions. As a continuous system, it was anticipated to mimic extrusion processes and overestimate closed mold operations, such as injection molding. This assumption was supported by a two-year study that found extrusion processes generated a higher level of emissions than injection molding.<sup>6</sup> Emissions from the die head of the extruder system were captured and analyzed for volatile organic compounds (VOC; volatile organic material or VOM in Illinois), particulate matter (PM-10), and a variety of hazardous air pollutants (HAPs).

The SPI sponsored studies of the commonly used resins PP, PS, PE and PA are attached to my pre-filed testimony as *Exhibits 3 –6* and will be referred to herein as the “SPI Studies.” The EVA/EMA study (*Exhibit 7*) is provided for informational purposes. A study on ABS, conducted at the same laboratory as the SPI Studies, is also provided for informational purposes. *Exhibit 8*. That study was not conducted under SPI auspices, and thus I have limited knowledge of the conditions under which it was performed.

The above-mentioned studies form the basis for the plastics industry’s understanding of emissions from these processes and are recognized by industry and regulatory authorities, as defining emission factors for both simple extrusion and the extrusion process utilized in PIM.

What these studies demonstrate is that extrusion processing of different resins under various operating conditions produces different types and amounts of emissions. *Exhibit 9* attached to my pre-filed testimony is a chart summarizing the emission factors

developed in the SPI Studies for each of the emissions of interest for the resins studied. The information in this chart was compiled from information contained in each of the SPI Studies to make it easier to review this data in this proceeding.

As can be seen from this chart, the emissions of interest include VOM, PM and a variety of HAPs.

The type and volume of emissions varies from a high of approximately 0.4 lb of VOM per ton of resin processed to a low of approximately 0.1 lb per ton of resin processed. HAPs ranged from a high of approximately 0.3 lb per ton of resin processed to a low of approximately 0.02 lb per thousand tons of resin processed. Particulate emissions ranged from a high of approximately 0.5 lb PM per ton of resin processed to a low of approximately 0.02 lb PM per ton of resin processed for the commonly used resins. *Exhibit 10*

Based on the emission factors developed in the SPI Studies and the capacity of PIM machines, across the range from small to large PIM machines discussed above, one can obtain an overview of the annual volume of emissions associated with PIM processes. *Exhibit 11* to my pre-filed testimony is a chart showing the estimated volume of VOM, PM and HAP emissions in tons per year, associated with the various types of resins studied by SPI. As can be seen from this chart, the emissions range from a high of 0.2 tons per year of VOM to a low of 0.002 tons per year VOM. HAP emissions range from 0.1 tons per year to 0.0004 thousandths of a ton per year. PM emissions range from 0.2 tons per year to 0.0004 tons per year.

That concludes my pre-filed testimony describing the PIM industry, PIM process and types and volumes of emissions associated with the processing of various resins. I

appreciate the opportunity to testify and am available to answer any questions the Board or other participants in this proceeding may have.

Respectfully submitted,

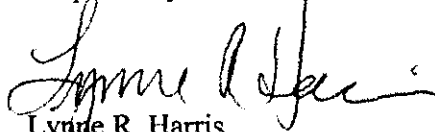

Lynne R. Harris

On Behalf of

The Society of the Plastics Industry, Inc.

---

<sup>1</sup> Barlow, A.; Contos, D.; Holdren, M. W.; Garrison, P.; Harris, L.; Janke, B. (1996). Development of emission factors for polyethylene processing. *J. Air & Waste Manage. Assoc.*, 46, 569-580.

<sup>2</sup> 2002 Economic Census, Manufacturing Industry Series, All Other Plastics Product Manufacturing: 2002. US Census Bureau, EC02-311-326199 (RV), December 2004; p. 2.

<sup>3</sup> SPI Plastics Data Source. (2001). State-by-State Guide to Resin and Equipment, p. A-2.

<sup>4</sup> Survey of North American Injection Molders. *Plastics News*. April 11, 2005.

<sup>5</sup> Rosato, D.V., Rosato, D.V. and Rosato, M.G. (2000). *Injection Molding Handbook*. 3<sup>rd</sup> ed. Boston: Kluwer Academic Publishers. p. 28.

<sup>6</sup> Forrest, M.J., Jolly, A.M., Holding, S.R., and Richards, S.J. (1995). Emissions from Processing Thermoplastics. *Annals of Occupational Hygiene*, 39 (1), 35-53.

**EXHIBITS**

1. Plastic Injection Molding Machine Diagram, *Injection Molding Handbook*, 3<sup>rd</sup> Edition, 2000, Kluwer Academic Publishers.
2. Plastic Injection Molding Equipment Manufacturer Product Information.
3. Adams, K.; Bankston, J.; Barlow, A.; Holdren, M.; Meyer, J.; Marchesani, V. (1999) "Development of Emission Factors for Polypropylene Processing," *J. Air & Waste Manage. Assoc.*, 49, 49-56.
4. Rhodes, V.; Kriek, G.; Lazear, N.; Kasakevich, J.; Martinko, M.; Heggs, R.P.; Holdren, M.W.; Wisbith, A.S.; Keigley, G.W.; Williams, J.D.; Chuang, J.C.; Satola, J.R. (2002) "Development of Emission Factors for Polycarbonate Processing" *J. Air & Waste Manage. Assoc.*, 52, 781-788.
5. Barlow, A.; Contos, D.; Holdren, M.; Garrison, P.; Harris, L.; Janke, B (1996) "Development of Emission Factors for Polyethylene Processing" *J. Air & Water Manage. Assoc.*, 46, 569-580.
6. Kriek, G.; Lazear, N.; Rhodes, V.; Barnes, J.; Bollmeier, J.; Chuang, J.; Holdren, M.; Wisbith, A.; Hayward, J.; Pietrzyk, D. (2001) "Development of Emission Factors for Polyamide Processing," *J. Air & Waste Manage. Assoc.*, 51, 1001-1008.
7. Barlow, A.; Moss, P.; Parker, E.; Schroer, T.; Holdren, M.; Adams, K. (1997) "Development of Emission Factors for Ethylene-Vinyl Acetate and Ethylene-Methyl Acrylate Copolymer Processing," *J. Air & Waste Manage. Assoc.*, 47, 1111-1118.
8. Contos, D.A.; Holdren, M.W.; Smith, D.L.; Brooke, R.C.; Rhodes, V.L.; Rainey, M.L. (1995) "Sampling and Analysis of Volatile Organic Compounds Evolved During Thermal Processing of Acrylonitrile Butadiene Styrene Composite Resins," *J. Air & Waste Manage. Assoc.*, 45, 686-694.
9. SPI Studies Emission Factor Summary Chart.
10. Estimated Emissions Using a Range of Emission Factors and Throughputs.
11. Overview of Estimated Emissions.

PLASTIC INJECTION MOLDING MACHINE DIAGRAM

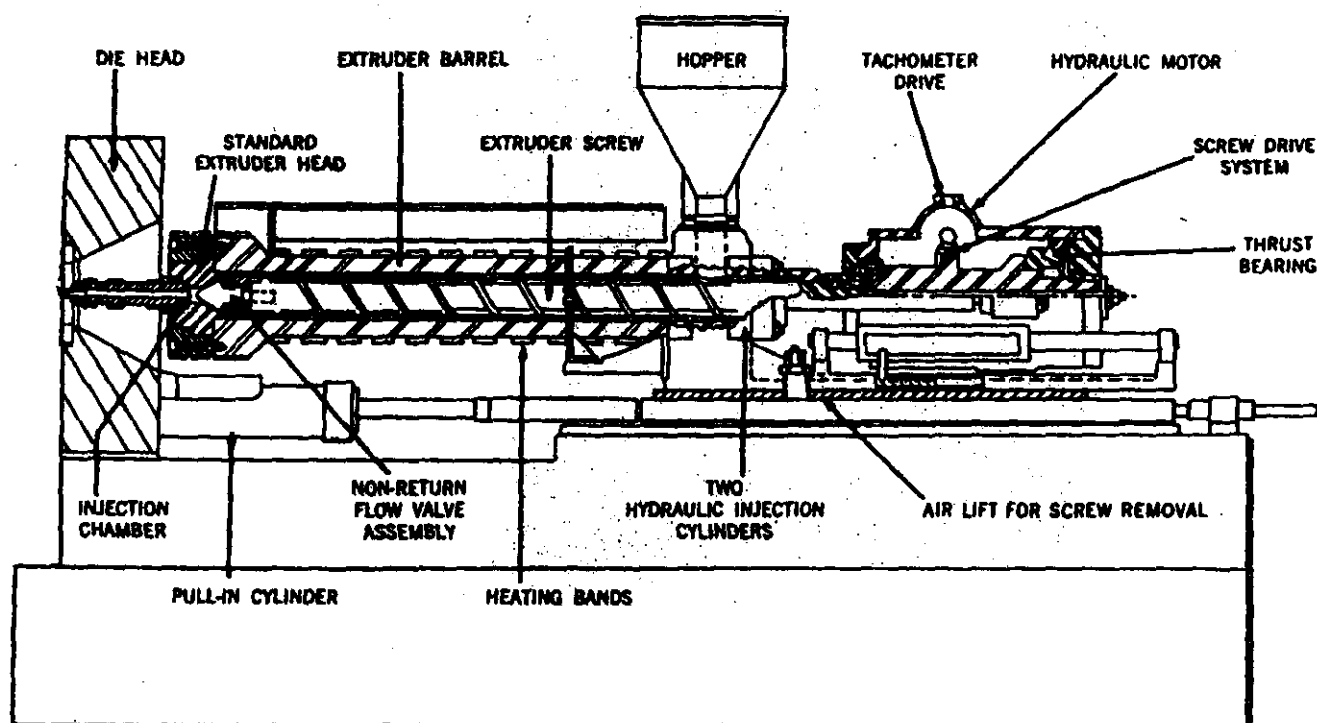

Fig. 2-2 In-line reciprocating screw unit with hydraulic drive schematic.

Source: *Injection Molding Handbook*, 3<sup>rd</sup> Edition, 2000, Kluwer Academic Publishers.



**PLASTIC INJECTION MOLDING  
EQUIPMENT MANUFACTURER PRODUCT INFORMATION**

Equipment Manufacturer	Model	Tonnage	Maximum Shot Weight (oz)	(1) Cycle Time (sec)	(2) Maximum Throughput (lb/hr)
A	A-1	17	0.47	10	11
		33	0.95	25	9
		55	1.95	25	18
		110	6.02	25	54
		165	10.59	25	95
		330	31.4	50	141
(3) A	A-2	990	362	100	815
		1100	362	100	815
		1500	540	100	1215
		1760	769	150	1154
		2200	769	150	1154
		3000	1054	200	1186
		3500	1054	200	1186
		4000	1054	200	1186
B	B-1	28	1.7	25	15
		40	2.8	25	25
		55	7	25	63
		90	9.3	25	84
		110	9.3	25	84
		120	12.7	30	95
		140	12.7	30	95
		165	12.7	30	95
		220	20.1	45	101
B	B-2	85	5	25	45
		120	10.7	25	96
		170	14.7	35	95
		230	25.4	50	114
		300	40.3	80	113
		400	59.2	100	133
		500	89.6	100	202
C	C-1	30	3.76	25	34
		50	6.04	25	54
		80	11.9	25	107
		130	11.9	25	107
		280	34	50	153
C	C-2	150	28	50	126
		200	28	50	126
		250	28	50	126
		300	28	50	126
C	C-3	225	22	45	110
		310	54	90	135
		450	76	100	171
		550	105	100	236

**NOTES:**

(1) Typical cycle time is from 10 to 100 seconds for injection molding machines with typical injection capacity of 4 to 100 ounces and typical tonnage of 50 to 600 tons.

References: Typical cycle times - Chemical Engineering Department, University of Connecticut  
[www.engr.uconn.edu/cheg/polymer/inimold.htm](http://www.engr.uconn.edu/cheg/polymer/inimold.htm)

Typical injection capacity and tonnage - Rosato, Rosato and Rosato. Injection Molding Handbook 2000; page 28.  
3rd edition. Boston, Kluwer Academic Publishers.

(2) Max. Throughput (lb / hr) = Max. Shot Weight (oz / cycle) x lb / 16 oz x cycle / cycle time (sec) x 3600 sec / hr

(3) Injection molding machines outside of the typical injection capacity and tonnage ranges.

**TECHNICAL PAPER**ISSN 1047-3289 *J. Air & Waste Manage. Assoc.* 49:49-56

Copyright 1999 Air &amp; Waste Management Association

**Development of Emission Factors for Polypropylene Processing****Ken Adams***The Society of the Plastics Industry, Inc., Washington, District of Columbia***John Bankston***Aristech Chemical Corporation, Pittsburgh, Pennsylvania***Anthony Barlow***Quantum Chemical Company, Cincinnati, Ohio***Michael W. Holdren***Battelle, Columbus, Ohio***Jeff Meyer***Amoco Polymers, Inc., Alpharetta, Georgia***Vince J. Marchesani***Montell North America, Inc., Wilmington, Delaware***ABSTRACT**

Emission factors for selected volatile organic compounds and particulate emissions were developed during extrusion of commercial grades of propylene homopolymers and copolymers with ethylene. A small commercial extruder was used. Polymer melt temperatures ranged from 400 to 605 °F. However, temperatures in excess of 510 °F for polypropylene are considered extreme. Temperatures as high as 605 °F are only used for very specialized applications, for example, melt-blown fibers. Therefore, use of this data should be matched with the resin manufacturers' recommendations.

An emission factor was calculated for each substance measured and reported as pounds released to the atmosphere per million pounds of polymer processed [ppm (wt/wt)]. Based on production volumes, these emission factors can be used by processors to estimate emission

quantities from polypropylene extrusion operations that are similar to the resins and the conditions used in this study.

**INTRODUCTION**

The Clean Air Act Amendments of 1990 (CAAA90) mandated the reduction of various pollutants released to the atmosphere. Consequently, companies are being faced with the task of establishing an "emissions inventory" for the chemicals released or generated in their processes. The chemicals targeted are those that either produce volatile organic compounds (VOCs) and/or compounds that are on the U.S. Environmental Protection Agency's (EPA) list of 189 hazardous air pollutants (HAPs). Title V of the amended Clean Air Act establishes a permit program for emission sources to ensure an eventual reduction in emissions. When applying for a state operating permit, processing companies are first required to establish a baseline of their potential emissions.<sup>1</sup>

In response to the needs of the plastics industry, the Society of the Plastics Industry, Inc. (SPI) organized a study to determine the emission factors for extrusion of homopolymer and copolymer of polypropylene. Sponsored by ten major resin producers, the study was performed at Battelle, an independent research laboratory. This work follows a previous SPI/Battelle study on the emissions of

**IMPLICATIONS**

This study provides quantitative emissions data that were collected during extrusion of homopolymers and copolymers of propylene. These data are directly related to production volumes and can be used as reference points to estimate emissions from similar polypropylene resins extruded on similar equipment.

polyethylene<sup>2</sup> and was performed in conjunction with emission studies on ethylene-vinyl acetate and ethylene-methyl acrylate copolymers.<sup>3</sup>

A review of the literature reveals that thermo-oxidation studies have been performed on polypropylene.<sup>4,5</sup> The primary concerns about these previous emissions data are that they were generated using static, small-scale,<sup>6</sup> or otherwise unspecified procedures.<sup>7,8</sup> These procedures may not adequately simulate the temperature and oxygen exposure conditions typically encountered in the extrusion process. That is, in most extruders, the polymer melt continuously flows through the system, limiting the residence time in the heated zones. This contrasts with static procedures, in which the polymer may be exposed to the equivalent temperature, but for an effectively longer period of time, thus resulting in an exaggerated thermal exposure. In a similar way, the concern over oxygen in the industrial extrusion process is minimized as the extruder screw design forces entrapped air back along the barrel during the initial compression and melting process. The air exits the system via the hopper; consequently, hot polymer is only briefly in contact with oxygen when it is extruded through the die. Again, this is in contrast to static testing, in which hot polymer may be exposed to air for extended periods of time. In view of these concerns, the accuracy of data obtained from these procedures may be limited when used to predict emissions generated by polypropylene processors.

As an alternative to small-scale static technology, a better approach is to measure emissions directly from the extrusion process. Since the type and quantity of emissions are often influenced by operational parameters, the ideal situation is to study each process under the specific operating conditions of concern. Parameters that can alter the nature of the emissions include extruder size and type, melt temperature and rate, the air-exposed surface to volume ratio of the extrudate, the cooling rate of the extrudate, and the shear effect from the extruder screw. Other variables related to the material(s) being extruded can also influence emissions. These include resin type, age of the

resin, additive package, and any additional materials added to the resin prior to extrusion. If a processor uses recycled materials, the thermal history is also an important factor.

In view of these variables, a considerable task would be to devise and conduct emission measurement studies for all major extrusion applications. Therefore, SPI's objective in this work was to develop baseline emission factors for polypropylene processing under conditions that would provide reasonable reference data for processors involved in similar extrusion operations.

The five resin types evaluated were a reactor grade homopolymer, a controlled rheology homopolymer with and without antistat, a random copolymer, and a reactor impact copolymer. The samples used were mixtures of commercial resins from the sponsoring companies. The test matrix used was designed to provide emissions data as a function of their resin type and typical melt temperature(s). This information is provided in Table 1, together with the average additive content of the resin mixtures. These are typical additives normally found in polypropylene.

A small commercial extruder was equipped with a 1.5-in. screw and fitted with an eight-strand die. The emissions were measured over a 30-min. period and were related to the weight of resin extruded. The emission factor for each substance measured is reported as pounds evolved to the atmosphere per million pounds of polymer processed [ppm(wt/wt)]. Processors using similar equipment can use these emission factors as reference points to assist in estimating emissions for their specific process.

**Table 1.** Polypropylene emission test runs; resin characteristics additive concentration and melt temperature.

Run No. Sequence	Resin Type	Melt Flow Rate (g/10 min @ 230 °C)	Number of Resins In Composite	Melt Temp (°F)	Average Additive Concentration (ppm)
1	Controlled Rheology	30-35	6	400	Antioxidant 1,700
2	Homopolymer			510	PA* 1,000
3	Non Antistat			605	
4	Controlled Rheology	30-35	6	490	Antioxidant 1,700
	Homopolymer				AS** 3,400
	with Antistat				PA* 2,500
5	Reactor Grade	3-7	7	490	Antioxidant 1,700
6	Homopolymer			570	PA* 900
7	Reactor Impact	3-10	4	505	Antioxidant 2,500
	Copolymer				PA* 1,500
	15-20 wt % EPR				
8	Random Copolymer	3-7	3	510	Antioxidant 2,000
	3-6 wt % Ethylene				PA* 2,200
					Slip/AB 3,000

\*Process aid

\*\*Antistat

The substances targeted for monitoring included particulate matter, VOCs, light hydrocarbons (ethane, ethylene, and propylene), aldehydes (formaldehyde, acrolein, acetaldehyde, and propionaldehyde), ketones (acetone and methyl ethyl ketone), and organic acids (formic, acetic, and acrylic acid). These are the analytes of interest, either because they are on the HAPs list, as stated earlier, or they are the expected thermal and thermo-oxidative breakdown products of the polymers tested.

**EXPERIMENTAL**

In the following section, brief descriptions of the extruder, the entrainment zone, and sampling manifolds are provided. Details of the sampling methods, procedures, and analytical instrumentation are provided elsewhere.<sup>2,12</sup>

**Experimental Process Conditions**

An HPM Corporation 15-hp unvented extruder was used to process the polypropylene test sample mixtures at Battelle. The extruder was equipped with a 1.5-in. single screw (L/D ratio of 30:1) and fitted with an eight-strand die (Figures 1 and 2). Extruded resin strands were allowed to flow into a stainless steel drum located directly under the die head (Figure 2). Processing conditions, shown in Table 2, were selected to be representative of commercial processing applications. The order of the polypropylene emissions test runs is listed in Table 1.

**Capture and Collection of Emissions**

Emissions released at the die head were separately collected for 30 min. during the extrusion runs (Table 3). Emissions from the hopper were excluded from analysis since previous emission studies showed their contribution to be insignificant (less than 2% of the total).<sup>2</sup> Table 3 shows the sampling strategy and overall analytical scheme employed for the polypropylene test runs.

**Die Head Emissions**

Emissions released at the die head during extrusion were captured at the point of release in a continuous flow of clean air. A portion of this air flow was subsequently sampled downstream is described in the following paragraphs. The emissions were initially captured in a stainless steel enclosure surrounding the die head (Figure 3). The air stream was

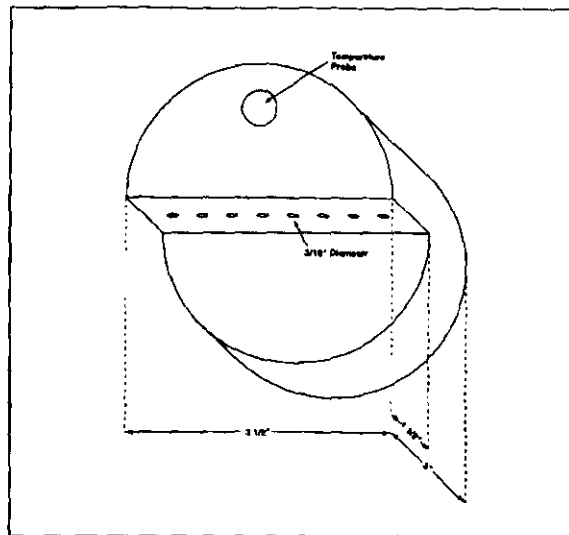

**Figure 1.** Extruder strand die head used in polypropylene emissions testing program.

immediately drawn through a divergent nozzle entrainment cone, which provided a sheath of clean air between the die head emission flow and the walls of the carrier duct. This minimized interaction of the hot exhaust with the cooler duct walls.

The total air flow employed for capturing die head emissions was set at 700 L/min. This was composed of the die head entrainment flow at 525 L/min, the sheath flow at L/min, and 75 L/min of residual air flow that was made up from room air drawing into the open bottom of the stainless steel die head enclosure. This residual air flow was used to facilitate effective capture of emissions from

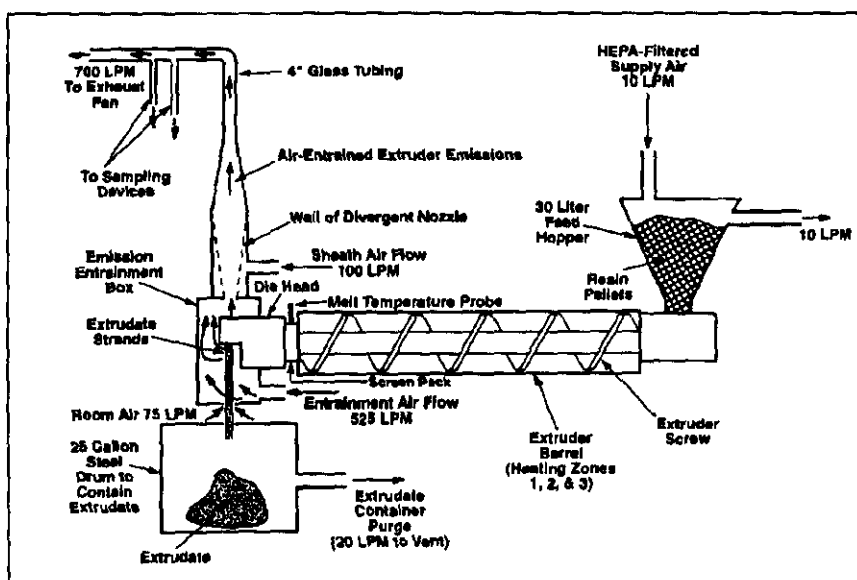

**Figure 2.** View of the extruder system and the various sampling locations.

**Table 2.** Resin throughput and key flow parameters during the polypropylene extrusion runs.

Test Run No.	1	2	3	4	5	6	7	8
<b>Extruder Conditions</b>								
Resin Type	Controlled rheology homopolymer	Controlled rheology homopolymer	Controlled rheology homopolymer	Controlled rheology homopolymer (with antistat)	Reactor grade homopolymer	Reactor grade homopolymer	Reactor impact copolymer (15-20 wt % EPR)	Random copolymer (3-6 wt % ET)
Melt Flow Rate	MFR 30-35	MFR 30-35	MFR 30-35	MFR 30-35	MFR 3-7	MFR 3-7	MFR 3-10	MFR 3-7
Average Die Head	400	510	605	490	490	570	505	510
Melt Temp (°F)								
Zone 3 Temp (°F)	428	488	568	471	497	643	496	497
Zone 2 Temp (°F)	403	430	469	320	369	436	369	369
Zone 1 Temp (°F)	382	318	315	308	312	313	300	308
Pressure (psig)	< 50	< 50	< 50	< 50	750	250	400	200
Resin Throughput [(lb/hr)/(gms/min)]	12.1/ 91.6	9.29/ 70.3	9.23/ 69.8	7.58/ 57.4	53.8/ 407	41.9/ 317	39.5/ 299	23.6/ 179
Rotor Speed (rpm)	98	98	98	98	83	68	83	83
Run Duration (min)	30	30	30	30	30	30	30	30
<b>Air Flows</b>								
Total Manifold Flow (L/min)	700	700	700	700	700	700	700	700
Flow Rate Into Sheath Area (L/min)	100	100	100	100	100	100	100	100
Flow Rate Into Entrainment Area (L/min)	525	525	525	525	525	525	525	525
Flow Rate Through Hopper (L/min)	10	10	10	10	10	10	10	10
Flow Through Tubes for Carbonyls (L/min)	0.5	0.5	0.5	0.5	0.5	0.5	0.5	0.5
Flow Through Tubes for Organic Acids (L/min)	5	5	5	5	5	5	5	5
Flow Into Canisters (L/min)	0.16	0.16	0.16	0.16	0.16	0.16	0.16	0.16
Flow Through 402 THC Analyzer (L/min)	1	1	1	1	1	1	1	1
Flow Through Filter Holder (L/min)	15	15	15	15	15	15	15	15

**Table 3.** Analytical scheme for polypropylene test runs.

Substances Monitored	Organic Acids	Aldehydes/ Ketones	Particulate	VOCs			
				Heavy Hydrocarbon	Light Hydrocarbon		
Collection Media	KOH Impregnated Filter	DNPH Tube	Glass Fiber Filter	SUMMA Canister			
Analytical Method	Desorption With Dilute H <sub>2</sub> SO <sub>4</sub> and Analysis by Ion Exclusion Chromatography/UV	Desorption With Acetonitrile and Analysis by HPLC	Gravimetric	Modified TO-14			
				HP-1 Fused Silica Capillary Column		Al <sub>2</sub> O <sub>3</sub> /Na <sub>2</sub> SO <sub>4</sub> Capillary Column	
				GC/MS	GC/FID	GC/FID	
Sampling Location		Manifold					
Melt Temp (°F)	Run No.	Number of Samples Analyzed					
400	1	2	2	1	1	2	1
510	2	2	2	1	1	2	1
605	3	2	2	1	1	2	1
490	4	2	2	1	1	2	1
490	5	2	2	1	1	2	1
570	6	2	2	1	1	2	1
505	7	2	2	1	1	2	1

the polymer. These flows are depicted in Figures 2 and 3. An orifice plate and control valve were used to set the flow at each location. A calibrated mass flow meter was used before and after the test runs to verify the settings. The flow setpoints were within  $\pm 3\%$  of the stated values.

Die head emissions were transported by the 700-L/min air flow to a sampling point 10 ft downstream of the die head using 4-inch-diameter glass tubing. The location for this sampling point (Figure 2) was based on previous studies performed at Battelle that involved design, engineering, implementation, and proof-of-principle stages for the pilot plant system.<sup>2,12</sup>

Two separate sampling manifolds were used at the sampling location; one for collecting gases and vapors and the other for collecting particulates (Figure 4). For gases and vapors, a 10-L/min substream was diverted from the main emission entrainment stream using a 0.5-inch stainless steel tube (0.425 inch i.d.) wrapped with heating tape and maintained at 50 °C. VOCs and oxygenates were sampled from this manifold. Similarly, particulates were sampled isokinetically from a separate 15-L/min substream using a 0.25-inch stainless unheated steel probe (0.1375 in. i.d.)

Two different methods were used to measure VOC emissions. One was the Beckman 402 Hydrocarbon Analyzer, which continually analyzed the air emission stream throughout the run and provided a direct reading of all VOC substances responding to the flame ionization detector. The other method used an evacuated canister for sample collection and gas chromatography for analysis. With this method, total VOCs were determined by summing up the heavy hydrocarbon (containing a carbon number ranging from  $C_3$  through  $C_{14}$ ) and light hydrocarbon (containing a carbon number ranging from  $C_2$  through  $C_3$ ) results.

The total VOCs determined with the 402 Analyzer are in general agreement with the VOC values obtained by summing up the light and heavy hydrocarbons species from the two GC methods. The 402 Analyzer results are consistently higher. The data obtained with the GC speciation method more closely resembles the TO-12 method, which is frequently used to measure source emissions of VOCs. Information on the TO-12 method and the GC speciation method (TO-14) can be obtained from the literature.<sup>9</sup>

This study did not include any measurements of emissions from the drum collection area, as all commercial extrusion processes quench the molten resin shortly

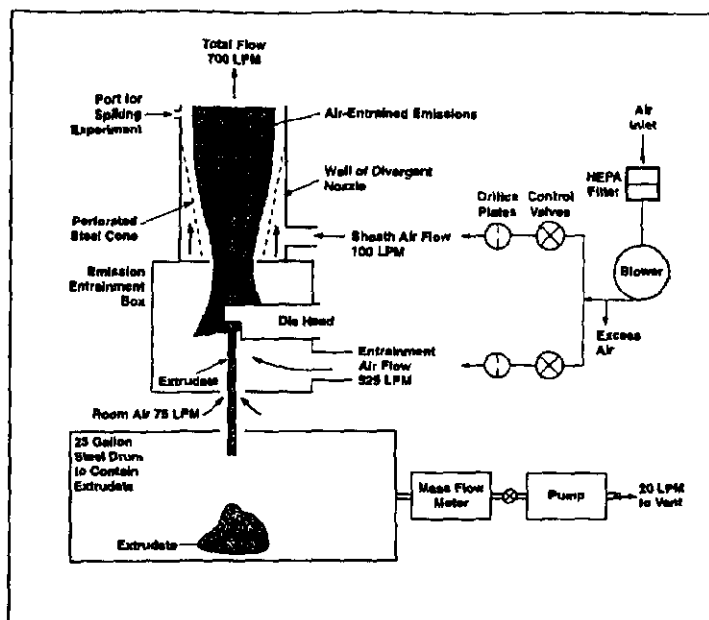

Figure 3. View of emission entrainment area.

after it exits the die. Emissions from the extrudate in the collection drum were prevented from entering the die head entrainment area by drawing air from the drum at 20 L/min and venting to the exhaust duct. Several background samples were taken, and smoke tubes were employed to confirm that the discharge from the entrainment area was not contributing material to the sampling manifold.

#### VALIDATION OF THE ANALYTICAL METHOD

The purpose of the manifold spiking experiments was to determine the collection and recovery efficiencies of the canister, acid, and carbonyl collection methods. During the first spiking experiment, all three collection methods were evaluated.<sup>2</sup> During the second spiking experiment, collection/recovery efficiencies were determined only for the canister sampling method. The results from the two spiking experiments are summarized in Table 4. The analytes measured by the spiking experiments are listed in column one. Column two shows the method used. Column three shows the calculated concentrations of the spiked compounds in the air stream of the manifold. The concentrations found from duplicate sampling and analyses, corrected for background levels, are shown in the next two columns. Finally, the average percent recovered is given in the last column.

The results from the first experiment are summarized in Table 4 to show recoveries of the manifold spiked compounds. The three organic acids were spiked at a nominal air concentration of about 0.6 to 0.8  $\mu\text{m/L}$ . Recoveries using the KOH-coated filters ranged from 107 to 122%.

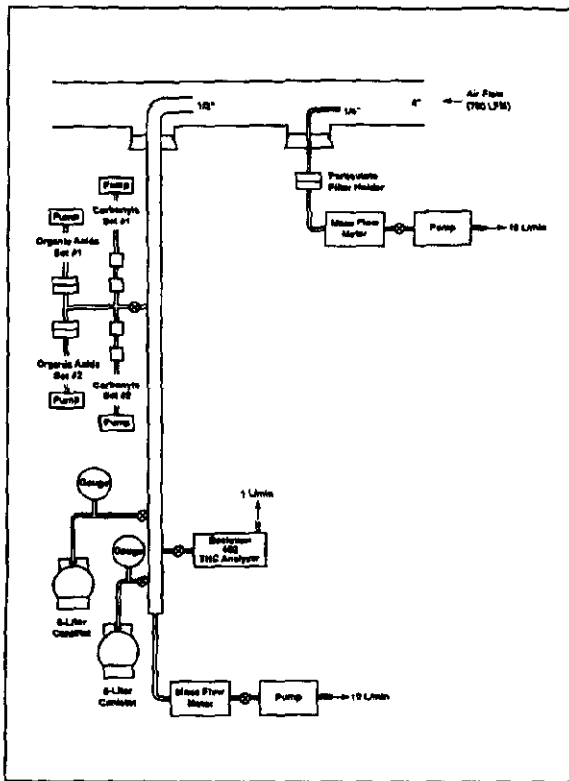

Figure 4. Sampling manifolds for emissions generated in die head.

Formaldehyde (1.63  $\mu\text{m/L}$ ) served as the surrogate for the aldehyde/ketone species, and the DNPH cartridge method showed a recovery of 130%. Deuterated benzene (0.092  $\mu\text{m/L}$ ) served as the representative compound for the canister collection method. The amount recovered was 95%.

During the second experiment, additional recovery data was obtained for the canister method using an expanded list of compounds. The additional compounds included deuterated benzene for comparison with the first experiment as well as benzene, methyl acrylate, deuterated methyl acrylate, and vinyl acetate. The expected spike level of these five species was nominally 0.24  $\mu\text{m/L}$ . Mass ions from the mass spectrometric detector that were specific for each compound were used in calculating recovery efficiencies, since the five species were not well-resolved with the analytical column (i.e., the two methyl acrylates were seen as one peak when monitoring the flame ionization detector).

#### POLYPROPYLENE EMISSION FACTOR RESULTS

The extrusion test run results from the eight polypropylene resin mixtures are shown in

Table 5. This shows the average die head melt temperature for each run and provides emission values in  $\mu\text{g/g}$  for the target species in the following categories: particulate matter, VOCs, and oxygenated species—aldehydes, ketones, and organic acids. The concentrations are directly translatable to pounds of material generated per million pounds of resin processed at that extrusion temperature. Figure 5 shows a bar graph of the just-mentioned emission categories by test run. Emissions plotted include particulate matter, VOCs as measured by the Beckman 402 Analyzer, VOCs as measured by the gas chromatographic speciation methods (e.g., light and heavy hydrocarbon methods), and, finally, the sum of the oxygenate species—aldehydes, ketones, and organic acids.

Examination of the five different resin mixtures extruded at a similar temperature (500 °F), that is, Test Runs 2, 4, 5, 7, and 8 show the controlled rheology homopolymer samples (2 and 4) generate the highest concentration of particulates and VOCs. Figure 5 clearly demonstrates the effect of melt temperature (400 to 600 °F) on emissions from a single resin type. Test Runs 1, 2, and 3 show, as expected, that emissions of all species increase with increasing extrusion temperature; Test Runs 5 and 6 show similar behavior, but to a lesser extent. Note that these data may not be extrapolated to the higher temperatures used for the melt spinning process.

Individual organic acid emissions ranged from less than the detection level to 6.6  $\mu\text{g/g}$ . Formic and acetic acid concentration varied by factors of 20 and 15, respectively, over the eight runs, but the relative levels of formic and acetic acid were similar (within a factor of 2) from test run to test run. Acrylic acid emissions, if any, were below the detection limits of the equipment. Test Runs 3

Table 4. Results from spiking experiments.

Analyte	Method	Spike Level ( $\mu\text{g/L}$ )	Recovery ( $\mu\text{g/L}$ )		Average % Recovered <sup>a</sup>
			Set 1	Set 2	
<b>First Experiment<sup>2</sup></b>					
Formic Acid	KOH filters	0.71	0.987	0.733	122 ± 18
Acetic Acid	KOH filters	0.77	1.023	0.640	121 ± 12
Acrylic Acid	KOH filters	0.59	0.687	0.567	107 ± 11
Formaldehyde	DNPH Cartridge	1.63	2.20	2.03	130 ± 5
Benzene-d <sub>6</sub>	Canister	0.092	0.088	0.066	95 ± 2
<b>Second Experiment<sup>a</sup></b>					
Benzene-d <sub>6</sub>	Canister	0.24	0.27	0.25	106 ± 4
Benzene	Canister	0.22	0.22	0.22	100
Methyl Acrylate-d <sub>3</sub>	Canister	0.25	0.26	0.24	100 ± 4
Methyl Acrylate	Canister	0.25	0.25	0.23	95 ± 4
Vinyl Acetate	Canister	0.24	0.28	0.25	110 ± 6

<sup>a</sup>Relative error is the relative percent difference: the absolute difference in the two samples multiplied by 100 and then divided by their average.

and 4 showed the highest levels of organic acids. The total organic acid emission values for these runs were 10.6 and 10.9  $\mu\text{g/g}$ , respectively. Figure 5 graphically shows the total oxygenates detected. Even at the highest melt temperatures employed in this study, the oxygenates contributed less than 11% of the total VOCs emitted.

The individual carbonyl species ranged in emission values from less than the detection level to 26.9  $\mu\text{g/g}$ . All eight species were resolved. Acetone was the most predominant component, followed by formaldehyde and acetaldehyde. Test Runs 3, 4, and 6 showed the highest level of total carbonyl species. The total carbonyl content from these runs were 73.8, 14.9, and 21.8  $\mu\text{g/g}$ , respectively.

Note that the EPA is proposing to revise its definition of VOCs for purposes of preparing state implementation plans (SIPs) to attain the national ambient air quality standards (NAAQS) for ozone under Title I of the CAAA90 and for the federal implementation plan for the Chicago ozone nonattainment area. The proposed revision would add acetone to the list of compounds excluded from the

definition of VOC on the basis that these compounds have negligible contribution to tropospheric ozone formation.<sup>10</sup>

The significance of this data becomes apparent when placed in the context of the 1990 CAAA90 definition of "major" source for VOC emissions. Categorization of an emission source as a major source subjects it to more stringent permitting requirements. The definition of a major source varies with the severity of the ozone nonattainment situation of the area where the source is located. The current VOC emission limits are 10 tons/yr for an emission source within an extreme ozone nonattainment classification, 25 tons/yr for a source in the severe classification, and 50 tons/yr for a source in the serious classification. Currently, the only extreme nonattainment area in the United States is the Los Angeles area.

The utility of this data can be illustrated in the following examples. Based on the emissions data developed in this effort, a processor with equipment similar to that used in this study can extrude annually up to 24.4 million pounds of controlled rheology polypropylene at a

**Table 5.** Summary of polypropylene extrusion emissions for generic resin grades (mg/g).

Test Run No.	1	2	3	4	5	6	7	8
<b>Extruder Conditions</b>								
Resin Type	Controlled rheology homopolymer	Controlled rheology homopolymer	Controlled rheology homopolymer	Controlled rheology homopolymer (with antistat)	Reactor grade homopolymer	Reactor grade homopolymer	Reactor impact copolymer (15-20 wt % EPR)	Random copolymer (3-6 wt % ET)
Melt Average Die Melt Temp (°F)	400	510	605	490	490	570	505	510
Particulate Matter	30.3	68.4	653	150	17.3	218	34.5	27.9
<b>VOCs</b>								
Beckman 402 - THC <sup>a</sup>	104	177	819	191	33.4	202	80.3	59.4
Heavy Hydrocarbons	79.1	175	587	104	24.6	127	65.1	29.8
Light Hydrocarbons								
Ethane	0.90	1.39	4.65	0.78	0.07	0.37	0.02	0.08
Ethylene	0.38	1.44	1.36	0.50	0.03	0.05	0.02	0.05
Propylene	0.21	0.80	13.9	0.70	0.12	2.24	0.06	0.26
<b>Aldehydes</b>								
Formaldehyde <sup>b</sup>	0.74	1.30	19.1	1.30	0.17	7.05	0.18	0.09
Acrolein <sup>b</sup>	< 0.01	0.05	0.81	0.14	< 0.01	0.10	< 0.01	< 0.01
Acetaldehyde <sup>b</sup>	0.46	0.54	15.8	0.53	0.09	5.63	0.20	0.08
Propionaldehyde <sup>b</sup>	0.05	0.07	1.60	3.31	0.02	0.97	0.95	0.02
Butyraldehyde	0.78	1.05	3.32	0.92	0.04	0.36	0.08	0.01
Benzaldehyde	0.12	0.14	5.21	0.51	0.08	0.88	0.02	0.06
<b>Ketones</b>								
Acetone	9.66	12.6	26.9	9.36	0.15	2.82	0.31	0.18
Methyl Ethyl Ketone <sup>b</sup>	0.19	0.24	9.62	0.26	0.07	5.23	0.04	0.04
<b>Organic Acids</b>								
Formic Acid	0.69	1.43	3.98	5.98	< 0.2	1.19	< 0.2	0.31
Acetic Acid	1.10	1.25	6.60	4.90	< 0.2	2.64	0.25	0.52
Acrylic Acid	< 0.08	< 0.08	< 0.08	< 0.08	< 0.08	< 0.08	< 0.08	< 0.08

<sup>a</sup>THC = Total hydrocarbons (methane is not included).<sup>b</sup>Hazardous air pollutants (HAPs).

Note: The emission values are averages from duplicate runs. In general, the differences were  $\leq \pm 15\%$ .



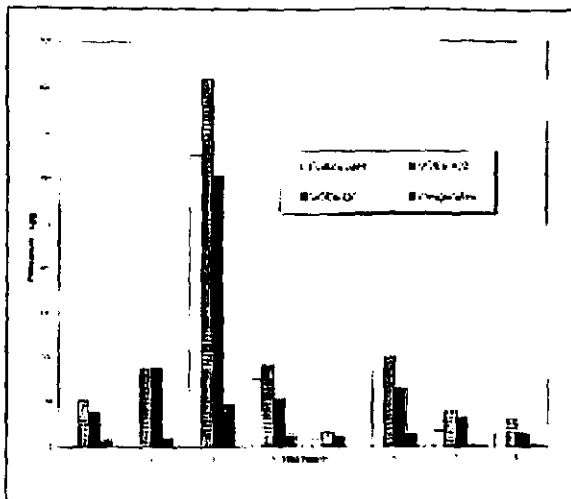

**Figure 5.** Bar graph showing the particulates, VOCs obtained with the 402 Analyzer, VOCs obtained by GC speciation and oxygenated organic species (factors in µg/g).

melt temperature of 600 °F or 1,156 million pounds of reactor grade homo polypropylene at a melt temperature of 500 °F without exceeding the 10-ton/yr limit for an extreme ozone nonattainment area.

## CONCLUSIONS

Based upon the results of this study, the following six conclusions are made:

- (1) For the resins studied, the major emission components were particulate matter and VOCs. Much lower amounts were found of the oxygenated species—aldehydes, ketones, and organic acids.
- (2) Emission rates are directly correlatable with the melt temperature.
- (3) Although the collection and MS speciation of VOCs most closely follows the EPA procedures (TO-12 and TO-14) for measuring VOCs, the more conservative approach using the Beckman 402 Analyzer, which yields higher VOCs values, should be employed.
- (4) The data provides polypropylene processors with a baseline for estimating the VOCs generated by the resins they handle on a daily basis under processing conditions similar to those used in this study and at the maximum melt temperatures reported. The following weights of each resin can be processed without exceeding the 10-ton limit of an "extreme" ozone nonattainment area: 24.4 million pounds of controlled rheology polypropylene at 600 °F, 99.0 million pounds of reactor grade homopolymer at 570 °F, 249.1 million pounds of reactor impact copolymer at 505 °F, and 336.7 million pounds of random copolymer at 510 °F.

- (5) In some cases, the emission factors determined in this study may overestimate<sup>11</sup> or underestimate emissions from a particular process. Professional judgement and conservative measures must be exercised as necessary when using the data for estimating emission quantities.
- (6) This study was not designed to meet the needs of industrial hygienists. However, this type of apparatus can be used at different extrusion conditions to gather data on other types of extrudates such as fiber, film, or sheet.

## REFERENCES

1. Sherman, L.M. "Clean-air rules challenge processors," *Plastics Technol.* 1995, 41, 2, 83-86.
2. Barlow, A.; Contos, D.; Holdren, M.; Garrison, P.; Harris, L.; Janke, B. "Development of emission factors for polyethylene processing," *J. Air & Waste Manage. Assoc.* 1996, 46, 569-580.
3. Battelle Final Report to the Society of the Plastics Industry, "Sampling and analysis of emissions evolved during thermal processing of ethylene-vinyl acetate and ethylene methyl acrylate resin composites," March 1995.
4. Hoff, A.; Jacobson, S. "Thermal oxidation of polypropylene close to industrial processing conditions," *J. Applied Polym. Sci.* 1982, 27, 2, 539.
5. Patel, S.H.; Xanthos, M. "Volatile emissions during thermoplastics processing—A Review," *Advances in Polym. Technol.* 1995, 14, 67.
6. Hoff, A.; Jacobson, S. "Thermo-oxidative degradation of low density polyethylene close to industrial processing conditions," *J. Applied Polym. Sci.* 1981, 26, 3, 409-3, 423.
7. Hughes, T.W.; Boland, R.F.; Rinaldi, G.M. Source Assessment: Plastic Processing, State of the Art. Monsanto Research Corporation. March 1978, EPA-600/2-78/004C, 27-28.
8. "Air facility subsystem source classification codes and emission factor listing for criteria air pollutants," EPA, March 1990, EPA 450/4-90/003.
9. Compendium of Methods For The Determination of Toxic Organic Compounds in Ambient Air, U.S. Environmental Protection Agency, June 1988. Available from NTIS as PB90-127374.
10. *Fed. Regist.* 1994, 59, 189, 49, 877.
11. Forrest, M.J.; Jolly, A.M.; Holding, S.R.; Richards, S.J. "Emissions from processing thermoplastics," *Annals of Occupational Hygiene.* 1995, 39, 1, 35-53.
12. Battelle Final Report to the Society of the Plastics Industry, "Sampling and analysis of emissions during thermal processing of polypropylene resin mixtures," April 1995.

### About the Authors

Anthony Barlow, Ph.D., is a product steward for Quantum Chemical Company. John Bankston is supervisor of product regulation at Aristech Chemical Corporation. Michael Holdren is a senior research scientist at Battelle Memorial Institute. Vince Marchesani, Ph.D., is director of health and environmental affairs for Montell North America. Jeffrey Meyer, Ph.D., is manager of polymer physics and testing at Amoco Polymers, Inc. Ken Adams (corresponding author) is assistant technical director for the Society of the Plastics Industry, Inc., 1801 K St., NW, Suite 600K, Washington, DC 20006.

**TECHNICAL PAPER**ISSN 1047-3289 *J. Air & Waste Manage. Assoc.* 52:781-788  
Copyright 2002 Air & Waste Management Association**Development of Emission Factors for Polycarbonate Processing****Verne L. Rhodes***Product Regulatory Services, Inc., Gulf Breeze, Florida***George Kriek and Nelson Lazear***Bayer Corporation, Pittsburgh, Pennsylvania***Jean Kasakevich***The Dow Chemical Company, Midland, Michigan***Marie Martinko***The Society of the Plastics Industry, Inc., Washington, DC***R.P. Heggs, M.W. Holdren, A.S. Wisbith, G.W. Keigley, J.D. Williams, J.C. Chuang, and J.R. Satola***Battelle, Columbus, Ohio***ABSTRACT**

Emission factors for selected volatile organic compounds (VOCs) and particulate emissions were developed while processing eight commercial grades of polycarbonate (PC) and one grade of a PC/acrylonitrile-butadiene-styrene (ABS) blend. A small commercial-type extruder was used, and the extrusion temperature was held constant at 304 °C. An emission factor was calculated for each substance measured and is reported as pounds released to the atmosphere/million pounds of polymer resin processed [ppm (wt/wt)]. Scaled to production volumes, these emission factors can be used by processors to estimate emission quantities from similar PC processing operations.

**INTRODUCTION**

The Clean Air Act Amendments of 1990 (CAAA) mandated the reduction of various pollutants released to the atmosphere. As a result, companies are faced with the task of establishing an "emissions inventory" for the chemicals generated and released by their production processes. The chemicals targeted are those considered volatile organic compounds (VOCs) and those that are on the U.S.

Environmental Protection Agency's (EPA) current list of 188 hazardous air pollutants. Title V of the CAAA establishes a permit program for emission sources to ensure an eventual reduction in these chemical emissions. When applying for a state operating permit, processing companies are required to establish a baseline of their potential emissions.<sup>1</sup>

In response to the needs of the plastics industry, the Society of the Plastics Industry, Inc. (SPI) organized a study to determine the emission factors for extruding polycarbonate (PC) homopolymers, copolymers, and blends. Sponsored by two major resin producers, the study was performed at Battelle. This work follows previous SPI/Battelle studies on the emissions from acrylonitrile-butadiene-styrene (ABS),<sup>2</sup> polyethylene,<sup>3</sup> ethylene-vinyl acrylate and ethylene-methyl acrylate copolymers,<sup>4</sup> polypropylene,<sup>5</sup> and polyamide.<sup>6</sup>

There are limited literature references about emissions from PC, but most of these use static, small-scale procedures and were intended to predict emissions from either a fire scenario or worker exposure.<sup>7,8</sup> These procedures do not accurately simulate the temperature profile and oxygen exposure conditions typical of extrusion processing. Static testing usually exposes the resin to temperatures outside (both greater than and less than) typical extrusion temperature ranges and to atmospheric oxygen for extended periods of time. During commercial processing, the resin is molten for a few minutes at most, and the equipment is designed to force air out of contact with the melt in the barrel. Hot resin is in contact with oxygen

**IMPLICATIONS**

This study provides quantitative emission data collected while processing nine types of PC-based resins. These data are directly related to production throughput and can be used as reference points to estimate emissions from similar PC resins processed on similar equipment.

only briefly as it exits the die. In light of these differences, the data obtained from static tests are of limited use in predicting emissions from commercial processing.

Greater accuracy would, of course, be possible by measuring emissions from actual production equipment. Because operating parameters can influence the type and quantity of emissions, the greatest accuracy can be achieved by studying each process. Parameters that can influence emissions include extruder/injection molder size and type, melt temperature, processing rate, the ratio of air-exposed surface to the volume of the product, and shear effects caused by screw design. Variables associated with the material being processed that can also affect emissions include resin type, age of the resin, additive packages, and heat history of any recycled resin. It would be a daunting task to design and implement emission studies for all combinations of processing variables.

To strike a balance between the inapplicability of static tests and the complexity of measuring each process, SPI and major PC producers initiated work to develop baseline emission factors for PC processing under conditions that would provide reasonable reference data for similar processing operations. Extrusion was chosen as the preferred process because of its continuous nature and the ability to reach steady-state conditions for accurate measurement. Extrusion is also believed to have higher emission rates than other processes, such as injection molding operations,<sup>9</sup> and, therefore, should lead to more conservative extrapolations.

For the current study, three composites and six single resins were evaluated (see Table 1). The composites were a blend of Bayer Makrolon and Dow Calibre intended for food contact, compact discs, and UV-stabilized product markets. Bayer then tested three grades of Makrolon intended for radiation-stabilized, impact-modified, and ignition-resistant markets. Dow tested a radiation-stabilized grade, a branched PC, and a PC/ABS blend.

Table 1. Test runs for PC resins program.

Run No.	Resin	Sample Description Applications	Bayer MAKROLON	Dow CALIBRE	Extruding Temperature
1	Composite <sup>a</sup>	Food contact	3108	201	304 °C
2	Composite <sup>a</sup>	Compact discs	MAS-140 and CD2005	XU 73109.01L	304 °C
3	Composite <sup>a</sup>	UV stabilized	3103	302	304 °C
4	Single	Radiation stabilized	RX-2530		304 °C
5	Single	Impact modified	T-7855		304 °C
6	Single	Flame retarded	6485		304 °C
7	Single	Radiation stabilized		2081	304 °C
8	Single	Branched		603-3	304 °C
9	Single	PC/ABS blend		Pulse 830	304 °C

<sup>a</sup>Equal weights of resins dry blended.

Sampling and analytical measurements were conducted to determine emission factors for the following:

- total particulate matter;
- total VOCs;
- eight targeted VOCs: methylmethacrylate, monochlorobenzene, carbon tetrachloride, methylene chloride, *p/m*-xylene, styrene, *o*-xylene, and toluene; and
- four targeted semi-volatile organic compounds (SVOCs): diphenylcarbonate, bisphenol A, phenol, and *p*-cumyl phenol.

The targeted organic species were chosen based on their known or expected presence as thermal and thermal oxidative breakdown products of the polymers selected for study.

## EXPERIMENTAL

### Resin Blending Procedure

For runs 1–3, equal portions of each contributed resin were homogeneously mixed in 10-gal metal cans to form a composite blend immediately before the test run. Each container was filled to approximately two-thirds of capacity and then thoroughly blended by rotation on an automated can-rolling device. Each resin (runs 4–9) or resin mixture (runs 1–3) was placed in a drying hopper and dried at 126.7 °C for 6 hr to a dew point of –28.9 °C.

### Extruder Operating Procedures

The HPM Corp. 1.5-in., single-screw, 30:1 L/D (length-to-diameter ratio), 15-hp plastic extruder was thoroughly cleaned before the PC experiments. The extruder is capable of ~27.2 kg/hr throughput and 426.7 °C (maximum) barrel temperatures for the three heat zones. A specially constructed screw used on a previous polyamide study<sup>6</sup> was used and is shown in Figure 1. An eight-strand die head used in previous SPI-sponsored emission studies was used for this study and is shown in Figure 2. The die head was cleaned and inspected, the holes were reamed to a 3/16-in. diameter, and the surface was polished before the start of experimental work.

Each PC resin or mixture was initially extruded for 10–20 min before the actual test run to ensure stable process conditions. During this time, the total VOCs were monitored by online instrumentation to indicate equilibration of the exhaust effluent. A check of operating parameters was recorded initially and at 5-min intervals during each 20-min test run. These parameters included

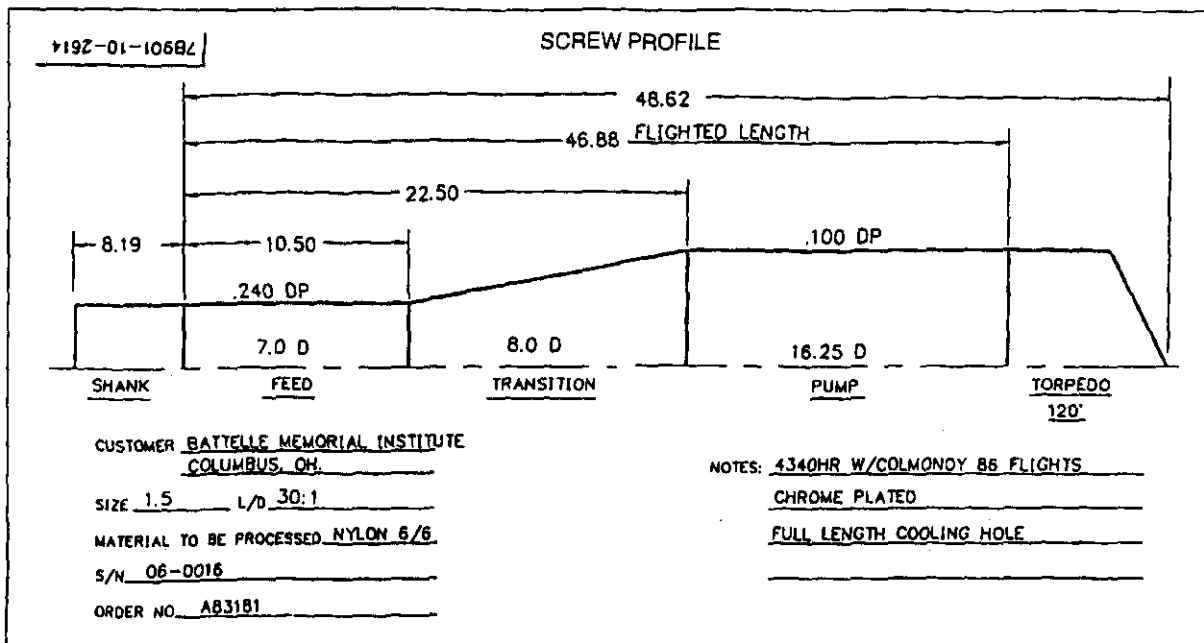

Figure 1. Screw profile (HPM Corporation).

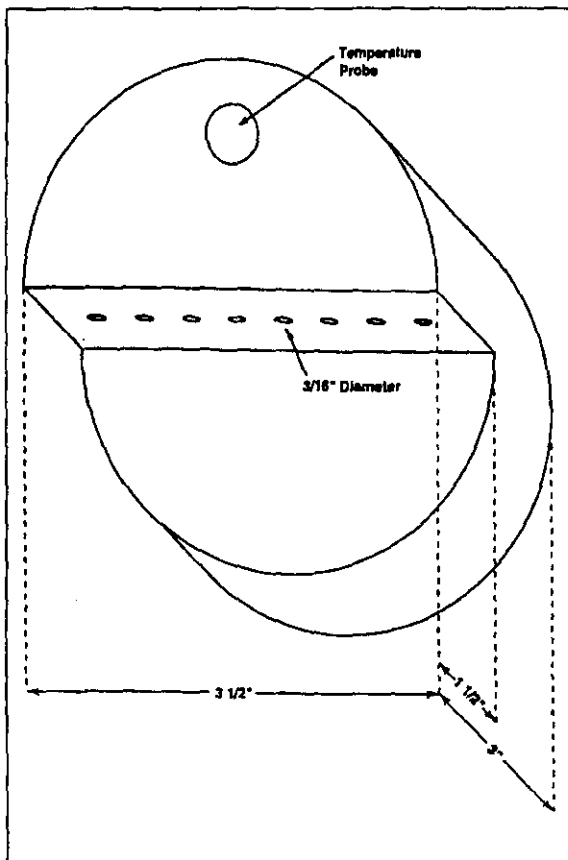

Figure 2. Extruder strand die head used in polyamide emissions testing program.

- check that the temperature at the die head had reached target and was stable;
- check that the RPM setting was at 60% (60 RPM);
- check of the extruder cooling water flow (in and out);
- check of manifold airflow rates; and
- check of the flow settings for all sampling equipment.

For each test run, a second repetitive run was carried out immediately after completion of the first run using the same operating conditions. Duplicate runs were conducted to allow better assessment of sampling and analytical precision.

#### Die Head Emission Collection

The stainless-steel emission-sampling manifold is shown in Figure 3. Emissions were entrained in pre-conditioned air (i.e., purified through a charcoal filter). Incoming filtered air was preset at a flow of 400 L/min using the variable flow blower and were maintained at this rate for all test runs. This flow was directed through the laminar flow head assembly and across the extrusion die head. The variable flow blower on the receiving side of the manifold system was adjusted to match the 400-L/min inlet flow. Additional flow from the sampling equipment resulted in ~10% greater flow into the receiving end of the sampling manifold. Smoke tubes were used during the test runs to confirm efficient transfer of the emissions.

The manifold was equipped with multiple ports for connecting the various sampling devices. Each port was 0.25-in. o.d. and protruded 1 in. into the airstream. The

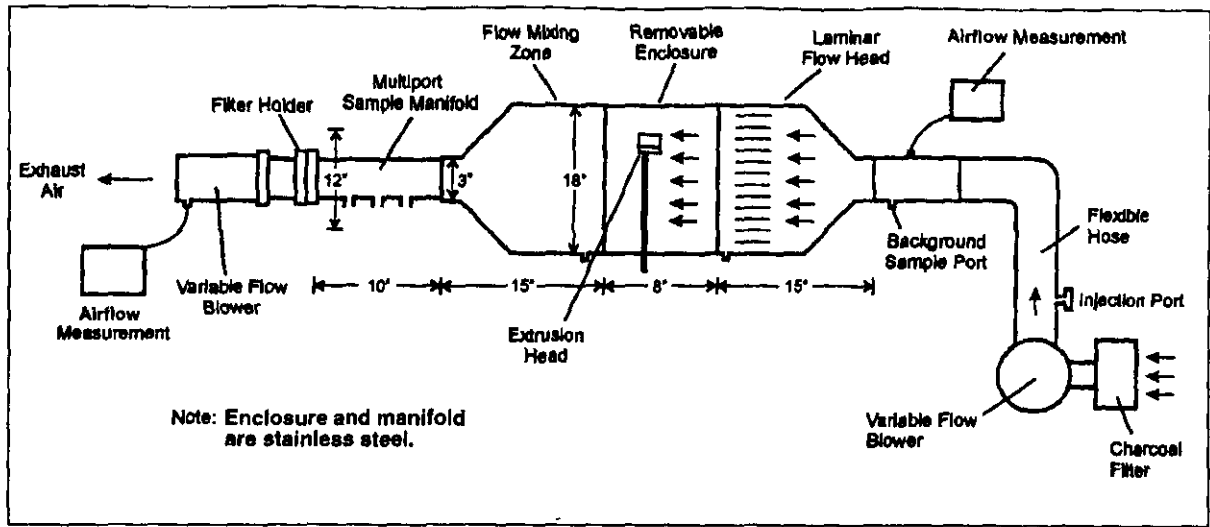

Figure 3. Emission enclosure apparatus.

manifold was also equipped with a 4-in. filter holder assembly and an in-line stainless steel probe (0.25-in. o.d.) connected to a 47-mm filter pack.

**Sampling and Analysis Methods**

The methods employed for characterizing the emissions from the resin extrusion process are summarized in Table 2. Detailed information is provided in the following sections.

**Target VOCs.** The collection and analysis of target VOCs followed EPA Method TO-14A guidelines. Evacuated and polished SUMMA 6-L canisters (100 mtorr) were used to collect whole air samples. The 6-L canisters were initially cleaned by placing them in a 50 °C oven and using a five-step sequence of evacuating to less than 1 torr (1 mm of mercury vacuum) and filling to ~4 psig (lb/in.<sup>2</sup> gauge) using humidified ultra-zero air. A final canister vacuum of 100 mtorr was achieved with an oil-free mechanical pump. Each canister was connected to the sampling manifold, and a 20-min integrated sample was obtained during the collection period. After collection, the canister pressure was recorded, and the canister was filled to 5.0 psig with ultra-zero air to facilitate repeated analyses of air from the canister.

Table 2. Sample collection and analysis methods for polycarbonate test runs.

Substances Monitored	Collection Media	Analytical Method
Total VOCs	Real-time monitoring	Continuous FID
Target SVOCs	XAD-2 adsorbent	GC/MS
Particulate matter	Glass fiber filter	Gravimetric weighing
Target VOCs	SUMMA canister	GC/parallel FID and MSD

A Fisons MD 800 gas chromatographic (GC) system equipped with parallel flame ionization detectors (FID) and mass spectrometric detectors (MSD) was used to analyze the target VOCs present in the canister samples. The GC contained a cryogenic preconcentration trap. The trap was a 1/8- × 8-in. coiled stainless steel tube packed with 60/80 mesh glass beads. The trap was maintained at -185 °C during sample collection and at 150 °C during sample desorption. A six-port valve was used to control sample collection and injection. Analytes were chromatographically resolved on a Restek Rtx-1, 60 m × 0.5 mm i.d. fused silica capillary column (1 μm film thickness). Optimal analytical results were achieved by temperature-programming the GC oven from -50 to 220 °C at 8 °C/min. The column exit flow was split to direct one-third of the flow to the MSD and the remaining flow to the FID. The mass spectrometer (MS) was operated in the total ionization mode so that all masses were scanned between 30 and 300 amu at a rate of 1 scan/0.4 sec. Identification of VOCs was performed by matching the mass spectra acquired from the samples to the mass spectral library from the National Institute of Standards and Technology (NIST). The sample volume was 60 cm<sup>3</sup>. With this sample volume, the FID detection level was 1.0 ppb. Detector calibration was based on instrument response to known concentrations of dilute calibration gas containing the target VOCs (traceable to NIST calibration cylinders). The calibration range extended from 0.1 to 1000 μg/L.

**Target SVOCs.** XAD-2 adsorbent tubes were used to collect SVOC emissions. Analyses were carried out using a GC/MS system. The adsorbent cleaning, sampling, and analytical procedures are described in the next paragraphs.

The sampling module consisted of an inlet jet equipped with a quartz fiber filter (Pallflex) and a glass cartridge packed with precleaned XAD-2 (Supelco). The filters were purged in an oven (450 °C) overnight before use. The XAD-2 cartridge assembly was sealed at both ends, wrapped with aluminum foil, and labeled with a sample code.

Single XAD cartridge sampling was conducted over a 20-min collection period using nominal flow rates of 4 L/min. An SKC sampling pump was used to draw the sample into the cartridge assembly. A mass flow meter (0–5 L/min) was used during the sampling period to measure actual flow rate. After sampling, the XAD-2 assembly was capped and stored in a refrigerator. For runs 1A, 2A, and 5B, a known amount of bisphenol-A (deuterated,  $d_6$ ) was spiked onto the XAD-2 cartridge just before sampling.

The filter/XAD-2 samples from each run were extracted separately with dichloromethane for 16 hr. The extracts were concentrated by evaporation with a Kuderna-Danish (K-D) apparatus to a final volume of 10 mL. The concentrated extracts were analyzed by GC/MS to determine SVOC concentrations.

A Hewlett Packard Model 5973 GC/MS, operated in the electron impact mode, was used. Sample extracts were analyzed by GC/MS in the full mass scan mode to determine SVOC levels. A fused silica capillary DB-5 column, 60 m  $\times$  0.32 mm i.d. (0.25  $\mu$ m film thickness), was used for analyte resolution. The initial GC oven temperature was 70 °C. After 2 min, the temperature was programmed

to 150 °C at 15 °C/min and then to 290 °C at 6 °C/min. Helium was used as the carrier gas. The MS was set to scan from  $m/z$  35 to 500 amu at 3 scans/sec. Identification of the target analyte was based on a comparison of mass spectra and retention times relative to the corresponding internal standards (naphthalene- $d_8$  and phenanthrene- $d_{10}$ ). Tentative identification of nontarget compounds was accomplished by manual interpretation of background-corrected spectra together with an online library search.

**Total Particulate Material.** The concentration of particulate emissions was determined by passing a sample of the exhaust effluent through a pre-weighed filter and then conducting a gravimetric analysis of the sampled filter. The pre-weighed filter (8  $\times$  10 in.) and holder were inserted into the exhaust port of the sampling manifold. The sample volume was determined from a calibrated orifice and Magnehelic gauge located on the sample manifold blower. A flow rate of 200 L/min was used during the 20-min test runs. Gravimetric analyses of the filter before and after sampling were carried out in a controlled environmental facility (temperature  $21 \pm 1$  °C, relative humidity  $50 \pm 5\%$ ). The filters were preconditioned to the controlled environment for 24 hr and then weighed.

**Total VOCs.** A VIG Industries Model 20 total hydrocarbon analyzer equipped with a hydrogen flame ionization

Table 3. Total manifold exhaust flow and resin throughput rates for generic PC resin grades.

Test Run No.	Resin Type	Orifice (inches of water)	Blower @ 140 °F or 60 °C (L/min)	Blower @ 75 °F or 24 °C (L/min)	Total VOC Analyzer (L/min)	XAD-2 Sampler (L/min)	Canister Sampler (L/min)	Total Manifold Flow (L/min)	Resin Throughput (g/min)
1A	Food contact	4	417	393	2	4.0	0.2	399.2	354
1B		4	417	393	2	4.0	0.2	399.2	333
2A	Compact discs	4	417	393	2	4.0	0.2	399.2	370
2B		4	417	393	2	4.0	0.2	399.2	368
3A	UV stabilized	4	417	393	2	3.9	0.2	399.1	341
3B		4	417	393	2	3.9	0.2	399.1	322
4A	Radiation stabilized	4	417	393	2	4.0	0.2	399.2	356
4B		4	417	393	2	3.9	0.2	399.1	359
5A	Impact modified	4	417	393	2	3.9	0.2	399.1	309
5B		4	417	393	2	3.9	0.2	399.1	310
6A	Ignition resistant	4	417	393	2	3.9	0.2	399.1	344
6B		4	417	393	2	3.9	0.2	399.1	351
7A	Radiation stabilized	4	417	393	2	4.0	0.2	399.2	348
7B		4	417	393	2	4.0	0.2	399.2	346
8A	Branched	4	417	393	2	4.0	0.2	399.2	325
8B		4	417	393	2	4.0	0.2	399.2	323
9A	PC/ABS blend	4	417	393	2	4.0	0.2	399.2	285
9B		4	417	393	2	4.0	0.2	399.2	287

Table 4. Summary of extrusion emissions of target chemicals from generic polycarbonate resin grades (µg/L).\*

Test Run No.	Resin Type	Particulate Matter	Total VOCs	Speciated VOCs (total)	Methyl methacrylate	Monochlorobenzene	Carbon Tetrachloride	Methylene Chloride	p,p'-DDE	Styrene	o-Xylene	Toluene	Target SVOCs	Diphenylcarbazone	Bis-phenol A	Phenol	p-Cumyl Phenol
1A	Food contact	7.52	34.20	28.23	<0.01	26.22	<0.01	<0.01	<0.01	0.02	<0.01	0.03	0.03	1.14	0.34	0.84	<0.01
1B	Compact discs	7.54	30.60	31.87	<0.01	26.10	<0.01	<0.01	<0.01	0.02	<0.01	0.03	0.03	1.32	0.30	0.89	<0.01
2A	UV stabilized	12.12	19.80	21.68	<0.01	20.38	<0.01	<0.01	<0.01	<0.01	<0.01	<0.01	<0.01	0.49	0.49	0.49	0.49
2B		11.80	21.60	22.43	<0.01	21.52	<0.01	<0.01	<0.01	<0.02	<0.01	<0.01	<0.01	0.37	0.28	0.28	<0.01
3A		24.77	32.40	39.43	<0.01	36.07	<0.01	0.29	0.08	0.02	0.02	0.03	0.03	1.91	0.28	0.43	<0.01
3B		24.89	32.40	42.89	<0.01	38.20	<0.01	0.29	0.08	0.02	0.02	0.03	0.03	2.21	0.27	0.98	<0.01
4A	Radiation stabilized	7.15	63.00	78.64	<0.01	50.61	<0.01	<0.01	<0.01	<0.01	<0.01	<0.01	<0.01	3.48	0.23	1.05	<0.01
4B		5.34	55.80	76.83	<0.01	51.14	<0.01	0.14	<0.01	0.02	0.02	<0.01	<0.01	4.21	0.17	1.07	<0.01
5A	Impact modified	16.12	90.00	114.5	58.26	28.58	<0.01	<0.01	<0.01	<0.01	<0.01	0.02	0.02	4.68	0.23	1.43	<0.01
5B		13.85	84.60	108.6	57.61	29.92	<0.01	<0.01	<0.01	<0.01	<0.01	0.02	0.02	4.94	0.30	1.59	<0.01
6A	Ignition resistant	8.01	16.20	6.56	0.03	5.25	<0.01	0.14	<0.01	<0.01	<0.01	0.02	0.02	1.56	0.10	0.59	<0.01
6B		8.49	18.00	8.43	<0.01	7.83	<0.01	<0.01	<0.01	<0.01	<0.01	<0.01	<0.01	1.62	0.10	0.57	<0.01
7A	Radiation stabilized	19.85	12.60	6.06	<0.01	0.05	<0.01	<0.01	<0.01	<0.01	<0.01	<0.01	<0.01	2.51	0.36	0.35	<0.01
7B		19.64	12.60	6.43	<0.01	0.02	<0.01	<0.01	<0.01	<0.01	<0.01	0.02	0.02	1.19	0.30	0.47	<0.01
8A	Branched	25.34	9.00	1.13	<0.01	0.07	0.18	<0.01	0.08	<0.01	0.02	0.02	0.02	0.55	0.24	0.21	<0.01
8B		26.58	9.00	1.41	<0.01	0.05	0.16	<0.01	0.09	<0.01	0.02	0.02	0.02	0.17	0.21	0.25	<0.01
9A	PC/ABS blend	98.96	84.60	135.9	<0.01	<0.01	<0.01	<0.01	49.05	47.81	0.31	1.25	1.25	0.25	0.47	0.92	<0.01
9B		99.56	82.80	118.8	<0.01	<0.01	<0.01	<0.01	43.30	39.57	0.26	1.14	1.14	0.14	0.44	0.82	<0.01

\*Micrograms of target chemical per liter of manifold exhaust flow.

detector (HFID) was used to continuously monitor the VOC content of the exhaust effluent. A heated sample line (149 °C) was connected to the extruder sample manifold, and the sample flow was maintained at 2 L/min. The analyzer was calibrated at the beginning of each test day against a NIST-traceable reference cylinder containing a mixture of propane in 42-µg/L ultra-zero air (minimal total hydrocarbons, water, CO<sub>2</sub>, CO, or other impurities). Linearity was demonstrated by challenging the analyzer calibration standards of 3, 46, 280, and 4480 µg/L of methane.

**Total Manifold Flow**

The total manifold exhaust flow for the individual test runs was needed for the eventual calculation of emission factors. Table 3 lists the total flows for each test run. The orifice ΔP value is the observed reading for each run. From the experimentally derived regression equation, flow = 74.223(ΔP) + 119.77 (R<sup>2</sup> = 0.9943), a flow rate (typically expressed as L/min) through the blower can be determined using this ΔP value. However, the flow across the orifice was originally calibrated at 75 °F (23.8 °C). The Rankine temperature (°R) is commonly employed (°R = °F + 459.67). To correct the flow to the manifold operating temperature of 140 °F (60 °C), the following flow orifice equation was used:

$$Q_2 = Q_1 \left[ \frac{T_2}{T_1} \right]^{1/2} \quad (1)$$

where Q<sub>1</sub> was the flow rate during test runs, Q<sub>2</sub> was the flow rate at 75 °F (535 °R), T<sub>1</sub> was the temperature of the exhaust air (°R), and T<sub>2</sub> was the temperature at calibration (535 °R).

A temperature correction factor of 0.944 was applied to the flow rate during the test runs to determine the flow rate at 75 °F. In addition, the flow rates from the individual sampling components were needed to obtain a total manifold flow. The total manifold flow is shown in the last row of Table 3. For all test runs, the total manifold flow was balanced at the preset incoming flow rate of 400 L/min.

Table 5. Summary of extrusion emissions of target chemicals from generic polycarbonate resin grades ( $\mu\text{g/g}$ ).

Test Run No.	Resin Type	Particulate Matter	Total VOCs	Specialized VOCs (total)	Methyl methacrylate	Monochlorobenzene	Carbon tetrachloride	Methylene Chloride	p-Xylene	Styrene	m-Xylene	Toluene	Target SVOCs	Biphenyl-carbonate	Bisphenol A	Phenol	p-Cumyl Phthalate
1A	Food contact	8.48	38.57	31.83	<0.01	29.56	<0.01	<0.01	0.02	0.02	<0.01	0.04	1.28	0.39	0.95	<0.01	<0.01
1B		9.04	36.68	38.20	<0.01	31.29	<0.01	<0.01	0.02	0.03	<0.01	0.04	1.59	0.36	1.07	<0.01	<0.01
2A	Compact discs	13.07	21.36	23.40	<0.01	21.98	<0.01	<0.01	<0.01	0.02	<0.01	<0.01	0.53	0.30	0.19	<0.01	<0.01
2B		12.80	23.43	24.33	<0.01	23.35	<0.01	<0.01	<0.01	0.02	<0.01	<0.01	0.40	0.22	0.15	<0.01	<0.01
3A	UV stabilized	28.99	37.93	46.16	<0.01	42.23	<0.01	0.34	0.09	0.02	0.03	0.03	2.23	0.33	0.51	<0.01	<0.01
3B		30.85	40.17	53.18	<0.01	47.36	<0.01	0.36	0.09	0.03	0.03	0.04	2.74	0.33	1.22	<0.01	<0.01
4A	Radiation stabilized	8.02	70.64	88.19	<0.01	56.75	<0.01	<0.01	<0.01	<0.01	<0.01	<0.01	3.90	0.26	1.18	<0.01	<0.01
4B		5.94	62.05	85.43	<0.01	56.87	<0.01	0.16	<0.01	0.02	0.02	<0.01	4.68	0.19	1.19	<0.01	<0.01
5A	Impact modified	20.83	116.3	147.9	75.27	36.92	<0.01	<0.01	0.03	<0.01	<0.01	0.03	6.04	0.30	1.84	<0.01	<0.01
5B		17.83	108.9	139.9	74.19	38.53	<0.01	<0.01	<0.01	<0.01	<0.01	0.02	6.36	0.38	2.04	<0.01	<0.01
6A	Ignition resistant	9.30	18.80	7.61	0.03	6.09	<0.01	0.16	<0.01	<0.01	<0.01	0.03	1.81	0.12	0.69	<0.01	<0.01
6B		9.66	20.47	9.58	<0.01	8.68	<0.01	<0.01	<0.01	<0.01	<0.01	<0.01	1.84	0.11	0.65	<0.01	<0.01
7A	Radiation stabilized	22.77	14.45	6.95	<0.01	0.06	<0.01	<0.01	<0.01	<0.01	<0.01	<0.01	2.88	0.41	0.41	<0.01	<0.01
7B		22.66	14.54	7.42	<0.01	0.02	<0.01	<0.01	<0.01	<0.01	<0.01	0.02	1.38	0.35	0.54	<0.01	<0.01
8A	Branched	31.12	11.05	1.39	<0.01	0.08	0.22	<0.01	0.10	<0.01	0.02	0.02	0.68	0.29	0.25	<0.01	<0.01
8B		32.85	11.12	1.75	<0.01	0.06	0.19	<0.01	0.11	<0.01	0.03	0.02	0.21	0.26	0.31	<0.01	<0.01
9A	PC/ABS blend	138.6	118.5	190.3	<0.01	<0.01	<0.01	<0.01	68.71	66.96	0.43	1.74	0.35	0.65	1.28	<0.01	<0.01
9B		138.5	115.2	165.3	<0.01	<0.01	<0.01	<0.01	60.23	55.05	0.36	1.58	0.19	0.61	1.14	<0.01	<0.01

\*Micrograms of target chemical per gram of test material.

**Emission Factors**

Amounts of the target chemicals detected in the manifold exhaust flow are shown in Table 4 ( $\mu\text{g/L}$ ). Emission factors for the amount of target chemicals detected for each resin tested ( $\mu\text{g/G}$ ) were calculated from the measured emission levels in Table 4 using this formula:

$$E = (C \times F) / O \quad (2)$$

where  $E$  was  $\mu\text{g}$  emissions/g processed resin,  $C$  was the measured concentration of emissions in  $\mu\text{g/L}$ ,  $F$  was the total manifold flow rate in  $\text{L/min}$ , and  $O$  was the resin throughput in  $\text{g/min}$ . Emission factors ( $\mu\text{g/G}$ ) are summarized in Table 5. Dimensional analysis shows that these emission factors can also be read as  $\text{lb emissions/million lb resin processed}$ .

**Significance of Emission Factors**

This study provides emission data collected during extrusion of various PC resins under specific operating conditions. The calculated emission factors can be used by processors to determine their expected annual emissions, which are used to categorize industrial sites under the 1990 CAAA. The most stringent current limitation is 10 t/year of VOC emissions within an extreme  $\text{O}_3$  management area. A processor with equipment similar to that used in this study could extrude 100–800 million lb/year of PC, depending upon the product mix, before achieving maximum permit levels. In less restricted areas, where the VOC emissions can be up to 50 t/year, the processor could potentially process 5 times this amount.

**RESULTS**

The primary results of the study are shown in Table 5. Some specific observations are as follows:

- (1) Overall emissions were low. Many grades indicated less than 100 lb emissions/million lb PC processed. Processing conditions differed from resin to resin, most notably by temperature, so emission data from different resins were not directly comparable.



- (2) The PC/ABS blend produced the highest emissions. This was predicted by the previous SPI-sponsored ABS study.
- (3) Impact-modified PC was the next highest emitter. Again, this was expected because this blend contained a toughener component.

Table 5 shows that very good precision was observed for the nine duplicate runs across all four measurement techniques. Calculated precision was 8% for particulate matter, 6% for VOCs, 14% for targeted VOCs, and 15% for SVOCs. Several of the targeted VOCs were either nondetectable or present at extremely low levels in all resins, particularly carbon tetrachloride, methylene chloride, *o*-xylene, and toluene. Others, such as *p,m*-xylene and styrene, were only present in the PC/ABS blend.

### CONCLUSIONS

The data collected in this study provide processors with a baseline for estimating emissions generated by PC resins processed under similar conditions. Discrepancies between total VOCs (as measured by the total hydrocarbon analyzer) and total SVOCs (as measured by gas chromatography) are a result of differences in instrument calibrations. The larger value of the two should be used to ensure conservative estimates. The emission factors reported here may not represent those for other PC types or for other methods of processing. Professional judgment and conservative measures must be exercised as necessary when using these data for estimating emission quantities.

### REFERENCES

1. Sherman, L.M. Clean-Air Rules Challenge Processors; *Plastics Technol.* 1995, 41 (2), 83-86.
2. Contos, D.A.; Holdren, M.W.; Smith, D.L.; Brooke, R.C.; Rhodes, V.L.; Rainey, M.L. Sampling and Analysis of Volatile Organic Compounds Evolved during Thermal Processing of Acrylonitrile-Butadiene-Styrene Composite Resins; *J. Air & Waste Manage. Assoc.* 1995, 45, 686-694.
3. Barlow, A.; Contos, D.; Holdren, M.; Garrison, P.; Harris, L.; Janke, B. Development of Emission Factors for Polyethylene Processing; *J. Air & Waste Manage. Assoc.* 1996, 46, 569-580.

4. Barlow, A.; Moss, P.; Parker, E.; Schroer, T.; Holdren, M.; Adams, K. Development of Emission Factors for Ethylene-Vinyl Acetate and Ethylene-Methyl Acrylate Copolymer Processing; *J. Air & Waste Manage. Assoc.* 1997, 47, 1111-1118.
5. Adams, K.; Bankston, J.; Barlow, A.; Holdren, M.; Marchesani, V.; Meyer, J. Development of Emission Factors for Polypropylene Processing; *J. Air & Waste Manage. Assoc.* 1999, 49, 49-56.
6. Kriek, G.; Barnes, J.; Lazear, N.; Bollmeier, J.; Pietrezyk, D.; Rhodes, V.; Holdren, M. Development of Emission Factors for Polyamide Processing; *J. Air & Waste Manage. Assoc.* 2001, 51, 1001-1008.
7. Ball, G.L.; Boettner, E.A. Volatile Combustion Products of Polycarbonate and Polysulfone; *J. Appl. Polymer Sci.* 1972, 16, 855-863.
8. Edgerley, P.G. A Study of Fume Evolution at Polymer Processing Temperatures; *Plastics Rubber Process. Applic.* 1981, 1 (1), 81-86.
9. Forrest, M.J.; Jolly, A.M.; Holding, S.R.; Richards, S.J. Emissions from Processing Thermoplastics; *Ann. Occup. Hygiene* 1995, 39 (1), 35-53.

#### About the Authors

M.W. Holdren and J.C. Chuang are senior research scientists, J.D. Williams and G.W. Keigley are master research technicians, A.T. Wisbith is a principal research scientist, J.R. Satola is a researcher, and R.P. Heggs is a program manager, all at Battelle Memorial Institute. Jean Kasakevich is environmental health and safety manager at the Dow Chemical Company. George Kriek is an associate research and development scientist at Bayer. Nelson Lazear is manager, Environmental & Industry Issues, at Bayer. Verne Rhodes is president of Product Regulatory Services, Inc. Marie Martinko (corresponding author) is manager, Environmental and Health Projects, for SPI, Suite 600K, 1801 K St. NW, Washington, DC 20006; phone: (202) 974-5330; e-mail: mmartink@socplas.org.

# Development of Emission Factors for Polyethylene Processing

**Anthony Barlow**

*Quantum Chemical Company, Allen Research Center, Cincinnati, Ohio*

**Denise A. Contos and Michael W. Holdren**

*Battelle, Columbus, Ohio*

**Philip J. Garrison**

*Lyondell Petrochemical Company, Lyondell Technical Center, Alvin, Texas*

**Lynne R. Harris**

*The Society of the Plastics Industry, Inc., Washington, D.C.*

**Brian Janke**

*Exxon Biomedical Sciences, Inc., East Millstone, New Jersey*

## ABSTRACT

Emission factors for selected volatile organic and particulate emissions were developed over a range of temperatures during extrusion of polyethylene resins. A pilot scale extruder was used. Polymer melt temperatures ranged from 500 °F to 600 °F for low density polyethylene (LDPE), 355 °F to 500 °F for linear low density polyethylene (LLDPE), and 380 °F to 430 °F for high density polyethylene (HDPE). An emission factor was calculated for each substance measured and reported as pounds released to the atmosphere per million pounds of polymer processed (ppm[wt/wt]). Based on production volumes, these emission factors can be used by processors to estimate emissions from polyethylene extrusion operations that are similar to the conditions used in this study.

## INTRODUCTION

The Clean Air Act Amendments of 1990 (CAAA) mandated the reduction of various pollutants released to the atmosphere, such as volatile organic compounds (VOCs) and the U.S. Environmental Protection Agency's (EPA) list of 189 hazardous air pollutants (HAPs). Title V of the amended

Clean Air Act establishes a permit program for emission sources to ensure a reduction in emissions. This program will radically impact tens of thousands of companies that will have to apply for state operating permits. In response to the needs of the industry, the Society of the Plastics Industry, Inc. (SPI) organized a study to measure emissions produced during polyethylene processing to assist processors in complying with the CAAA. Sponsored by nine major resin producers, the work was performed at Battelle, a not-for-profit research organization in Columbus, Ohio.

Prior to this study, a review of the literature revealed earlier polyethylene thermal emissions work that provided a wealth of qualitative data as well as some quantitative data on emissions. However, because of the concerns about the emission generation techniques used, the quantitative information is not deemed adequate for addressing the regulatory issues currently at hand.

The primary concern about previous emissions data is that they were generated using static, small-scale,<sup>1</sup> or otherwise unspecified procedures.<sup>2,3</sup> These techniques may not adequately simulate the temperature and oxygen exposure condition typically encountered in the extrusion process. That is, in most extruders, the polymer melt continuously flows through the system, limiting the residence time in the heated zones. This contrasts with static procedures where the polymer may be exposed to the equivalent temperature but for an effectively longer period of time, thus resulting in an exaggerated thermal exposure. In a similar way, the concern over oxygen in the industrial extrusion process is minimized as the extruder screw design forces entrapped air back along the barrel during the initial compression and melting process. The air exits the system via the hopper; consequently, hot polymer is only briefly in contact with oxygen

## IMPLICATIONS

This study provides quantitative emissions data collected during extrusion of polyethylene under specific operating conditions. The emission factors developed in this study are two orders of magnitude lower than those reported in an earlier EPA document. These data can be used by processors as a point of reference to estimate emissions from similar polyethylene extrusion equipment based on production volumes.

when it is extruded through the die. Again, this is in contrast to static testing where hot polymer may be exposed to air for extended periods of time. In view of these concerns, it is apparent that the accuracy of data obtained from these techniques may be limited when used to predict emissions generated by polyethylene processors.

As an alternative to small-scale static technology, a better approach would be to measure emissions directly from the extrusion process. Since the type and quantity of emissions are often influenced by operational parameters, the ideal situation would be to study each process under the specific operating conditions of concern. Parameters that can alter the nature of the emissions include: extruder size and type, extrusion temperature and rate, the air-exposed surface to volume ratio of the extrudate, the cooling rate of the extrudate, and the shear effect from the extruder screw. Other variables related to the material(s) being extruded can also influence emissions. These include: resin type, age of the resin, additive package, and any additional materials added to the resin prior to extrusion. If a processor uses recycled materials, the thermal history is also an important factor.

In view of these variables, it is clear that it would be a considerable task to devise and conduct emission measurement studies for all major extrusion applications. Therefore, SPI's objective in this work was to develop baseline emission factors for polyethylene processing under conditions that would provide reasonable reference data for processors involved in similar extrusion operations.

A pilot-scale extruder equipped with a 1.5 inch screw and fitted with an eight-strand die was chosen to process resins associated with three major applications: extrusion coating, blown film, and blow molding. The resin types were respectively: low density polyethylene (LDPE), linear low density polyethylene (LLDPE), and high density polyethylene (HDPE).

The emissions were measured over a 30-minute period and were related to the weight of resin extruded. The emission factor for each substance measured was reported as pounds evolved to the atmosphere per million pounds of polymer processed (ppm{wt/wt}). Processors using similar equipment can use these emission factors as relative reference points to assist in estimating emissions from their specific polyethylene application.

## EXPERIMENTAL

### Test Resins

Resins were selected for this study to cover the main processing applications for each major type of polyethylene, i.e., LDPE, LLDPE, and HDPE. Where applicable, project sponsors submitted a fresh sample of their most common resin grade using their standard additive package for each application. Equal portions of the sponsor samples were mixed by Battelle to provide an aggregate test sample for each resin type. The additives in the final LLDPE blend were slip (900 ppm), antioxidants/stabilizers (1775 ppm), process aids (580 ppm), and antiblock (4750 ppm). The additives in the final HDPE blend were antioxidants/stabilizers (350 ppm), and process aids (200 ppm). None of the LDPE resins contained additives in their formulation. All resins were eight months old or less at the start of testing.

### Experimental Process Conditions

A HPM Corporation 15 horsepower unvented extruder was used to process the polyethylene composite test samples at Battelle. The extruder was equipped with a 1.5 inch single screw (L/D ratio of 30) and fitted with an eight strand die.<sup>4</sup> Extruded resin strands were allowed to flow into a stainless steel drum located directly under the die head (see Figure 1). Process conditions were selected to be representative of several commercial processing applications. These are provided in Tables 1 and 2.

### Capture and Collection of Emissions

Emissions released at the die head and hopper areas were separately collected for 30 minutes during the extrusion runs. Table 3 shows the sampling strategy employed for the three types of polyethylene resins. Air sampling/collection rates for the various analytical samplers employed are provided in Table 4.

*Die Head Emissions.* Emissions released at the die head during extrusion were captured at the point of release in a continuous flow of clean

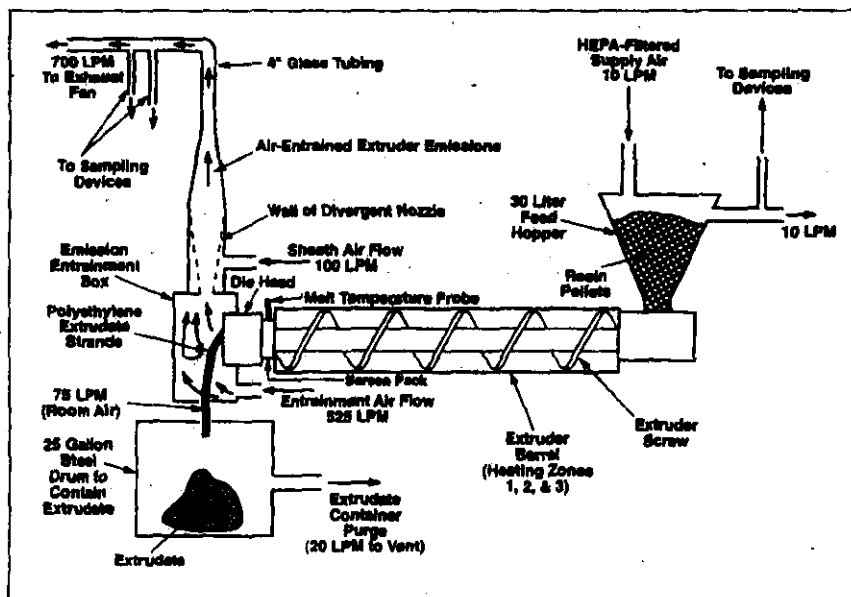

Figure 1. View of the extruder system and the various sampling locations.

**Table 1.** Resin type characterization and extrusion temperatures.

Resin Grade	Number of Resins in Composite	Use	Melt Index grams/10 minutes	Density g/cc	Extrusion Temperatures °F
LDPE	5	Extrusion Coating	7	0.92	500, 600
LLDPE	6	Blown Film	1	0.92	355, 395, 450, 500
HDPE	5	Blow Molding	0.2	0.95	380, 430

**Table 2.** Experimental process conditions.

	LDPE		LLDPE		HDPE			
Number of Extrusion Runs	2	2 <sup>a</sup>	1	1	1	2 <sup>b</sup>	1	2
Diehead Melt Temperature, °F	500	600	355 <sup>c</sup>	395	450	500	380	430
Zone 3 Temperature, °F	487	610	310	335	425	485	365	415
Zone 2 Temperature, °F	485	590	310	335	400	475	335	375
Zone 1 Temperature, °F	411	450	300	325	350	400	325	325
Pressure, psig	NA <sup>d</sup>	NA <sup>d</sup>	2,000	3,000	1,000	800	1,750	1,500
Resin Throughput lb/hr [gm/min]	38.3/290	38.3/290	37.0/280	36.9/279	38.1/288	38.4/291	37.4/283	34.1/258
Rotor Speed, rpm	96	96	96	96	96	96	96	96
Run Duration, min	30	30	30	30	30	30	30	30

<sup>a</sup> In addition to the duplicate tests at 600 °F, a (third) spiking test was performed at this temperature for benzene-d<sub>6</sub>.

<sup>b</sup> In addition to the duplicate tests at 500 °F, a (third) spiking test was performed at this temperature for formaldehyde and formic, acetic and acrylic acids.

<sup>c</sup> Screenpack was removed for 355 °F run with LLDPE to achieve target melt temperature at die head.

<sup>d</sup> NA = Not available.

air. A portion of this air flow was subsequently sampled downstream as described below. The emissions were initially captured in a stainless-steel enclosure surrounding the die head (see Figure 2). The air stream was immediately drawn through a divergent nozzle entrainment cone which provided a sheath of clean air between the die head emission

flow and the walls of the carrier duct. This minimized interaction of the hot exhaust with the cooler duct walls.

The total air flow employed for capturing die head emissions was set at 700 liters per minute. This was comprised of the die head entrainment flow at 525 liters per minute, the sheath flow at 100 liters per minute, and 75 liters per minute of residual air flow which was made up from room air drawn into the open bottom of the stainless-steel die head enclosure. This residual air flow was used to facilitate effective capture of the polymer emissions. These flows are depicted in Figures 1 and 2.

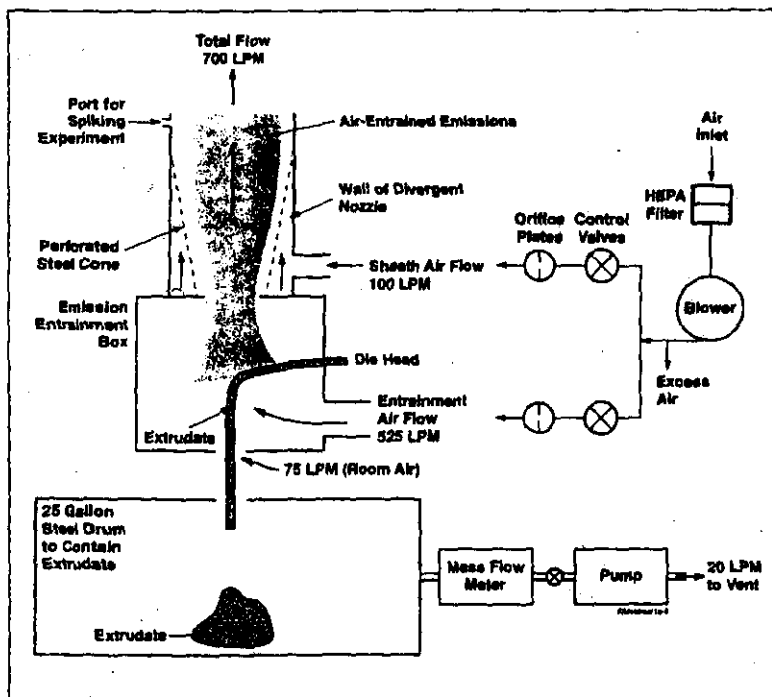
**Figure 2.** View of emission entrainment area.

Die head emissions were transported by the 700-liter per minute air flow to a sampling point 10 feet downstream of the die head using 4-inch diameter glass tubing. The location for this sampling point (see Figure 1) was based on previous studies performed at Battelle which involved design, engineering, implementation, and proof-of-principle stages for the laboratory system.<sup>4</sup>

Two separate sampling manifolds were used at the sampling location; one for collecting gases and vapors and the other for collecting particulates (see Figure 3). For gases and vapors, a 10-liter per minute substream was diverted from the main emission entrainment stream using a 1/2-inch stainless steel tube (0.425 inch i.d.) wrapped with heating tape

**Table 3.** Sample collection and analysis scheme.

Substances Monitored	Organic Acids	Aldehydes/ Ketones	Particulates	VOCs					
				HHC <sup>a</sup>	LHC <sup>b</sup>	HHC	LHC		
Collection Media	KOH Impregnated Filter	DNPH Tube	Glass Fiber Filter	SUMMA Canister					
Analytical Method	Desorption with Dilute H <sub>2</sub> SO <sub>4</sub> and Analysis by Ion Exclusion Chromatography/UV	Desorption with Acetonitrile and Analysis by HPLC	Gravimetric	Modified TO-14					
				HP-1 Fused Silica Capillary Column	Al <sub>2</sub> O <sub>3</sub> /Na <sub>2</sub> SO <sub>4</sub> Capillary Column	HP-1 Fused Silica Capillary Column	Al <sub>2</sub> O <sub>3</sub> /Na <sub>2</sub> SO <sub>4</sub> Capillary Column		
				GC/MS	GC/FID	GC/FID	GC/MS	GC/FID	GC/FID
Sampling Location	Manifold			Hopper					
	Number of Samples Analyzed Per Run								
	2	2	1	1	2	2	1	2	2

<sup>a</sup> HHC = Heavy hydrocarbons - includes C<sub>4</sub> to C<sub>16</sub> compounds present in canister samples

<sup>b</sup> LHC = Light hydrocarbons - includes ethane, ethylene, propylene

and maintained at 50 °C. VOCs and oxygenates were sampled from this manifold. Similarly, particulates were sampled from a separate 15-liter per minute substream using a 1/4-inch stainless unheated steel probe (0.1375 inch i.d.).

This study did not include any emissions from the drum collection area as all commercial extrusion processes quench the molten resin shortly after exiting the die. Any emissions from the extrudate in the collection drum were prevented from entering the die head entrainment area by drawing air from the drum at 20 liters per minute and venting to the exhaust duct.

**Hopper Emissions.** One of the underlying objectives of this study was to determine if substances evolved from the hopper area had any substantial contribution to the overall emissions. Any such emissions would likely be released during the heating and homogenization of the resin pellets in the initial zones of the screw. Since the process temperatures used in this area were substantially lower than those encountered at the die head, the likelihood of generating oxidation products or particulates is low. Therefore, only VOCs were monitored in this area.

Emissions released from the extruder throat of the hopper area were captured using a 30-liter stainless steel enclosure. The enclosure was equipped with a specially designed air-tight lid that would also allow rapid delivery of additional resin material as needed. As shown in Figure 1, a 10-liter per minute air flow was drawn through the enclosure to entrain any emissions and remove them to a downstream

location for analytical sampling. The sampling manifold was located 2 feet downstream of the hopper, and a portion of the 10-liter per minute flow was directed to the total VOC analyzer as well as to air sampling canisters (as shown in Figure 3).

#### Target Analytes

The chemicals measured in this study were selected by cross referencing the substances identified in the thermal emission literature<sup>1</sup> with the EPA's list of Hazardous Air Pollutants (HAPs). Many of these were oxygenated compounds, including acetaldehyde, acrolein, acrylic acid, formaldehyde, methyl ethyl ketone, and propionaldehyde. Although not on the HAPs list, acetic acid, acetone, and formic acid were added to the list of target analytes because they have been

**Table 4.** Air flow rates for capture and collection of emissions.

PARAMETER	LDPE (L/min)	LLDPE/ HDPE (L/min)
Total Manifold Flow	700	700
Flow Rate Into Sheath Area	100	100
Flow Rate Into Entrainment Area	525	525
Flow Rate Through Hopper	10	10
Flow Through Tubes for Aldehydes/Ketones	1	0.5
Flow Through Tubes for Organic Acids	10	5
Flow Into Canisters	0.16	0.16
Flow Through 402 THC Analyzer	1	1
Flow Through Filter Holder	15	15

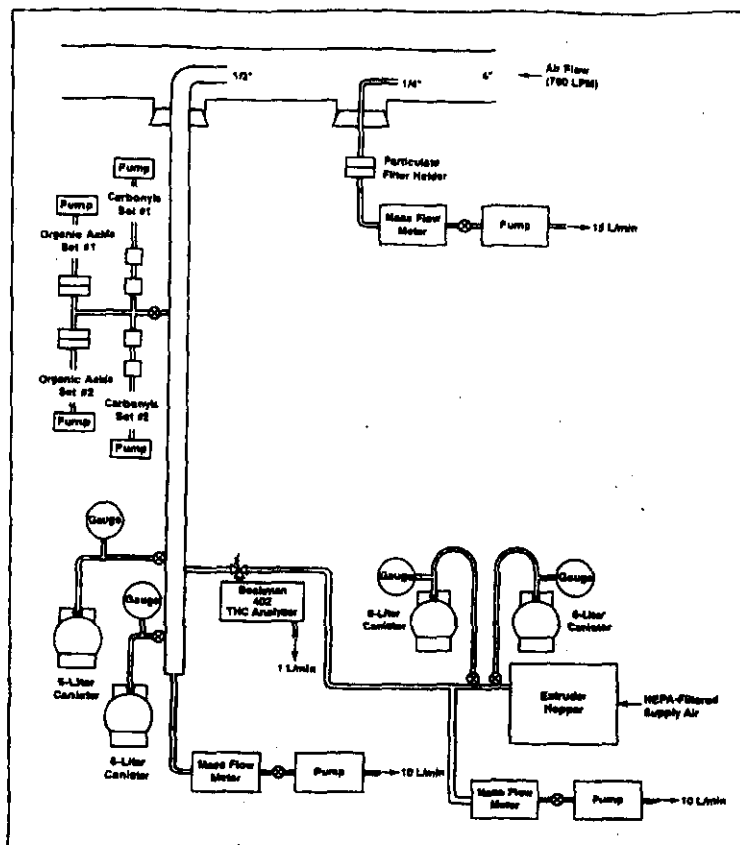

Figure 3. Sampling manifolds for emissions generated at die head and hopper.

commonly reported in the literature as thermal emission components, and they were easily included in the selected analytical protocol.

All gaseous and volatile hydrocarbons were grouped together and monitored as Volatile Organic Compounds (VOCs). This included compounds such as ethane, ethylene, propylene, butane, hexane, and octane. The analytical approach (discussed below) provided a collective measurement for a broad range of volatile hydrocarbons as well as the ability to speciate individual analytes, such as hexane, which is the only hydrocarbon on the HAPs list that is identified in the thermal emission literature associated with polyethylene.

Nonvolatile material (analyzed as "Particulates") was also included as a target substance as this material has been identified in some polyethylene thermal emissions by the study sponsors.

### Measurement of Emissions

Emission samples were analyzed as outlined in Table 3. The following classes of materials were measured: volatile organic compounds (VOCs), specific organic acids, specific aldehydes and ketones, and particulates. The emissions from each run were collected over the course of the 30-minute extrusion run and analyzed using the methods described below. VOCs were also monitored in real-time using an on-line heated probe flame ionization detection system.

*Volatile Organic Compounds (Time-integrated measurement).* Evacuated SUMMA polished 6-liter canisters were used to collect whole air samples. The 6-liter canisters were initially cleaned by placing them in a 50 °C oven, and utilizing a five-step sequence of evacuating to less than 1 torr and filling to ~4 psig using humidified ultra-zero air. A final canister vacuum of 100 mtorr was achieved with an oil-free mechanical pump. Each canister was connected to an orifice/gauge assembly during sampling to assure that an integrated sample was obtained over the 30-minute collection time. The orifice was sized to deliver ~160 mL/min. Canister samples were collected in duplicate at the manifold and hopper locations. After collection, the canister pressure was recorded and the canister was pressurized to 5.0 psig with ultra-zero air to facilitate repeated sampling and analysis of the canister.

Analyses of canister samples were accomplished with two gas chromatographic (GC) systems. The light hydrocarbon (LHC) GC system was used for the analyses of the target compounds ethane, ethylene, and propylene. The GC system was a Varian 3 Model 3600 equipped with a flame ionization detector (FID) and a sample cryogenic preconcentration trap. The trap was a 1/8-inch by 8-inch coiled stainless steel tube packed with 60/80 mesh glass beads. The trap was maintained at

-185 °C during sample collection and 100 °C during sample desorption. A six-port valve was used to control sample collection and injection. Analytes were chromatographically resolved with a Chrompack 50 meter by 0.32 mm i.d.  $Al_2O_3/Na_2SO_4$  fused silica capillary column (5- $\mu$ m film thickness). The column was operated isothermally at 50 °C to resolve the three target species and then ramped to 200 °C to purge the column of the remaining organic species. The sample size was 200 cc.

Propane was the detector calibration gas (traceable to NIST calibration cylinders). The calibration range extended from 0.5 to 1000 parts per billion carbon (ppbC). The ppbC unit is equivalent to part per billion by volume multiplied by the number of carbons in the compound. For the calibrant propane, 1 ppb by volume compound (or 3 ppb carbon) converts to 1.80 nanograms per liter of air (at 25 °C, 1 atm). For this study, an equal per carbon response was used for all hydrocarbon species (i.e., 1 ppbC of benzene will produce the same FID response as 1 ppbC of hexadecane). This procedure permits one calibrant to be used for calculating concentrations of all hydrocarbons species.<sup>4</sup>

A Hewlett Packard Model 5880 GC equipped with parallel flame ionization FID and mass spectrometric detectors MSD was used for the analyses of the heavier hydrocarbons which includes  $C_4$  to  $C_{16}$  compounds present in the canister samples. For the heavy hydrocarbons (HHC) analysis,

canisters were heated to 120°C to assure quantitative recovery of the C<sub>6</sub> to C<sub>16</sub> organic compounds. The GC contained a similar cryogenic preconcentration trap as described earlier. Analytes were chromatographically resolved on a Hewlett Packard HP-1, 50 m by 0.32 i.d. fused silica capillary column (1 μm film thickness). Optimal analytical results were achieved by temperature programming the GC oven from -50 °C to 200 °C at 8°/min. The column exit flow was split to direct one-third of the flow to the MSD and the remaining flow to the FID. The mass spectrometer was operated in the total ionization mode so that all masses were scanned between 35 and 300 daltons at a rate of 1 scan per 0.6 seconds. Identification of major components were performed by matching the mass spectra acquired from the samples to the mass spectral library from the National Institute of Standards and Technology (NIST). Interpretation also included manual review of all mass spectral data. The sample size was 80cc. Detector calibration was based upon instrument response to known concentrations of dilute benzene calibration gas (traceable to NIST calibration cylinders). The calibration range extended from 1.0 to 1,000 ppbC.

**Volatile Organic Compounds (Real-Time).** The real-time VOC method involved the Beckman 402 analyzer as an on-line continuous instrument using a heated probe flame ionization detection (FID) system. This method has been frequently used by Battelle to determine total organic concentrations from emission sources<sup>5,6</sup> and is the method specified in the Code of Federal Regulations (CFR) for determining the total hydrocarbon content from automobile exhaust.<sup>7</sup> It is essentially equivalent to EPA method 25A.<sup>8</sup>

A Beckman 402 heated probe (150 °C) flame ionization detector (HFID) was calibrated against a NIST traceable reference cylinder containing 94 ppmC of propane. Challenges with NIST traceable standards have demonstrated instrument linearity from a detection level of 1 ppmC to 1,000 ppmC.

The analyzer was connected to the sampling manifold and the hopper via a three-way solenoid valve. The valve was manually switched during the test runs so that VOC levels could be determined at both hopper and manifold locations. The analyzer was also used to verify the extruder system stability prior to the beginning of each test run.

VOC emission factors were determined using the average of real-time data acquired over the course of the 30-minute run.

**Organic Acids (Formic, Acetic, Acrylic).** The method for monitoring organic acids was successfully demonstrated by Battelle on an earlier automotive exhaust study for the determination of formic acid.<sup>9</sup>

The target analytes were formic, acetic and acrylic acids. An all-Teflon, three stage, 47-mm diameter filter holder (Berghof/America) was used for sample collection. Potassium hydroxide impregnated filters were prepared by dipping

47-mm diameter Gelman A/E glass fiber filters in a solution of 0.05 N KOH in ethanol. After dipping, the filters were placed individually on a stainless steel rack in a drying oven (45 °C). The oven was continually purged with zero air. Filters were stored in covered petri dishes in a dry box that was also purged with zero air. Each filter holder was loaded with 3 filters. The loaded filter holder was connected to the sampling manifold and the exit side of the holder was connected to a mass flow controller and pump assembly. The flow was set to 10 liters per minute for the LDPE resin runs and to 5 liters per minute for the LLDPE and HDPE test runs. Manifold samplers were collected in duplicate for each test run.

For analyses, filters were taken out of the filter-pack and individually placed into wide mouth jars containing 5 mL of a 3 mM H<sub>2</sub>SO<sub>4</sub> solution and 20 μL chloroform (to retard microbial losses). The jar was sonicated for 5 minutes and the solution was pipetted into a centrifuge tube. The tube was centrifuged to separate solid material from solution. A 200 μL aliquot was extracted and analyzed by ion exclusion chromatography with UV detection at 210 nm. A Bio-Rad Aminex HPX-87H HPLC column (7.8 mm i.d. by 300 mm length) was used to resolve the organic acids. The analytical method was shown to be linear for all three acids over a concentration range from the detection limit to 200 μg/mL. These concentrations are expressed in terms of the free organic acid in dilute sulfuric acid solution. The detection limits were 2 μg/mL for formic and acetic acid, and 0.2 μg/mL for acrylic acid. The standards were prepared with neat material (>99 % purity) diluted with a 3 mM H<sub>2</sub>SO<sub>4</sub> solution.

**Selected Aldehydes and Ketones.** The analysis of selected, aldehydes and ketones followed procedures identified in U.S. EPA Method TO-11.<sup>10</sup> The target analytes included formaldehyde, acetaldehyde, acrolein, acetone, propionaldehyde, and methyl ethyl ketone (MEK). C<sub>18</sub> Sep-Pak cartridges (Waters, Assoc.) coated with dinitrophenylhydrazine (DNPH) were used to collect carbonyl species. The stock reagent contained 0.2 grams of DNPH dissolved in 50 mL of acetonitrile. Orthophosphoric acid (50 μL) was added to provide an acidified solution. Each C<sub>18</sub> cartridge was precleaned with 2 mL of the acetonitrile and then loaded with 400 μL of DNPH stock reagent. Clean nitrogen gas was used to "dry" the DNPH coated cartridge. The coated cartridges were sealed with polyethylene plugs, placed in 10 cc glass vials and refrigerated until needed. Sample collection was carried out with two cartridges in tandem and a flow control/pump assembly downstream of the cartridges. The flow was set to 1 liter per minute for the LDPE resin runs and to 0.5 liters per minute for the LLDPE and the HDPE test runs. Manifold samples were collected in duplicate for each test run.

For analyses, individual cartridges were backflushed with 2 mL acetonitrile. An aliquot (30 μL) of the extracted solution was analyzed with a Waters Model 600 high performance liquid chromatograph equipped with a UV detector

(360 nm). Carbonyl separations were achieved with two Zorbax ODX (4.6 mm i.d. by 25 cm) columns connected in series. The mobile phase was acetonitrile/water; the flow rate was 0.8 mL/min. The analytical method was shown to be linear for the carbonyl species over a concentration range from the detection limit of 0.1 to 20 µg/mL. These concentrations were expressed in terms of the underivatized aldehyde/ketone in acetonitrile solvent. Standards were prepared with weighed amounts of individual DNPH-derivatives in acetonitrile solution.

**Particulate Matter.** Particulate emissions were collected under isokinetic conditions on a single in-line 25-mm glass fiber filter (1 µm pore size). The filter was attached to a 0.4 inch i.d. stainless steel sampling probe that was positioned in the 4" glass manifold airstream approximately 12 inches in front of the organic sampling manifold. Gravimetric analyses of the filter before and after sampling were carried out to determine mass loading.

#### Verification of the Measurement System

The ability of the system to accurately measure emissions was insured in a number of ways including ongoing observation and documentation of system performance as well as manifold spiking tests to measure the recovery of substances released at the die head in known quantities. These are further described below.

**Extruder Cleaning.** The extruder was thoroughly purged and cleaned<sup>4</sup> prior to extrusion of the polyethylene test resins. The test resins were extruded in order of increasing melt viscosity to minimize cross-contamination.

**Homogeneity of Emission Stream.** Prior to collection of air samples the air-entrained emissions were verified to be homogeneous at the sampling location for die head emissions. A Beckman 402 hydrocarbon analyzer and a TSI-Aerodynamic Particle Sizer were used for real-time, cross-sectional measurements during the extrusion of LDPE.

**Capture Efficiency.** Prior to testing, the capture efficiency of the air entrainment system at the die head was visually confirmed with the aid of smoke tubes (Mine Safety Appliance, #458480-Lot 176) prior to testing. The 25-gallon collection drum was also tested to ensure that potential emissions from this area were excluded from the entrainment system.

**System Equilibration.** Each test resin was extruded for 30 minutes prior to collection of emissions. During this period, total VOCs were monitored by the on-line Beckman 402 Hydrocarbon Analyzer to confirm equilibration of the system.

**Confirmation of Critical Operating Parameters.** Operating parameters were recorded initially and at 5 minute intervals during the 30-minute test. These include: extruder temperatures, extruder cooling water flow, air flows for the total manifold, sheath and entrainment zones and hopper, and flow settings of all sampling equipment.

**Manifold Spiking Tests.** Spiking studies were conducted at the outset of the study to verify the recovery efficiencies for each type of target analyte. Compounds representing VOCs, organic acids, and aldehydes were spiked into the sampling manifold about 2 feet downstream of the die head during the extrusion. The spike conditions are provided in Table 5. Additional details about the spiking experiments are provided below.

**VOCs (as benzene-d<sub>6</sub>).** Benzene-d<sub>6</sub> (deuterated benzene) was chosen to represent VOC recoveries in the spiking experiment because (1) its response on the GC/MSD is not prone to interferences from other expected VOC components, and (2) it is generally in the middle of the volatility range of the VOCs likely to be encountered.

A measured amount of benzene-d<sub>6</sub> was injected into a high pressure cylinder through a heated injection port and the cylinder was then filled with zero grade nitrogen to 1000 psig. The cylinder was equipped with a regulator and mass flow controller set at 10 liters per minute. The exit tube was

**Table 5.** Spike recovery data during extrusion.

Substance	Test Run	Amount Spiked	Amount of Spiked Material Recovered <sup>a</sup>	Percent Recovery and Relative Error <sup>b</sup>
Pounds Released Per Million Pounds of Polymer Processed ppm(wt/wt)				
Benzene-d <sub>6</sub>	LDPE @ 600 °F	0.22	0.21	95 ± 2
Formaldehyde	LLDPE @ 500 °F	3.93	5.10	130 ± 5
Formic Acid	LLDPE @ 500 °F	1.71	2.07	121 ± 18
Acetic Acid	LLDPE @ 500 °F	1.86	2.24	121 ± 12
Acrylic Acid	LLDPE @ 500 °F	1.42	1.51	106 ± 11

<sup>a</sup> The corresponding unspiked run showed a formaldehyde background level of 0.19 lb/million lb. The other species contained background levels less than the detection level.

<sup>b</sup> The relative error was determined as the difference in results from duplicate samples multiplied by 100 and then divided by the average amount.



inserted into the sampling manifold 2 feet downstream of the die head. The resulting manifold gaseous concentration was 0.092 µg/L. VOC samples were collected using a 6-liter evacuated canister to measure the "spiked" emission concentration as described under Measurement of Emissions.

**Organic Acids and Formaldehyde.** Aqueous solutions of the three organic acids and formaldehyde were mixed just before the spiking experiment commenced. The solution was dispensed at a rate of 0.57 mL/min using a CADD-PLUS infusion pump. The flow rate was digitally displayed and confirmed by measuring the weight loss of water after the experiment was completed. The water solution was directed through a heated injection system which was inserted into the manifold approximately 2 feet downstream of the die head. Complete evaporation of the water occurred at a temperature of 160 °C.

The spiking apparatus described above has been recently developed at Battelle<sup>11</sup> and has been successfully used for applications which require minimal temperature for the vaporization of liquid material. The vaporizer, shown in Figure 4, consists of a 21-cm length of thin wall 6.35-mm o.d. nickel chamber containing approximately 1 ml of water as the working fluid. A nickel capillary (0.60 mm o.d., 0.35 mm i.d.) coaxially traverses the length of the chamber. The outer surface of the capillary is in contact only with the vapor and liquid phase of the working fluid. The nickel chamber is heated with insulated resistance wire wrapped around and along the length of the chamber. A copper jacket between the resistance heater and the nickel chamber improves temperature uniformity of the chamber and provides additional thermal ballast for the working fluid. The generated gaseous concentrations in the manifold with the vaporizer were: formic acid, 0.60 µg/L; acetic acid, 0.71 µg/L; acrylic acid, 0.59 µg/L; and formaldehyde, 1.63 µg/L.

#### Calculation of Emission Factors

The emission concentrations in micrograms/L of air were converted to emission factors in micrograms/gram of

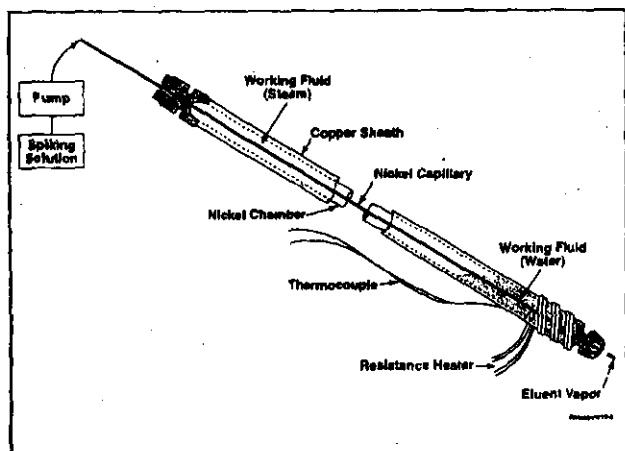

Figure 4. Battelle-developed water vaporizer.

processed resin using the following equation:

$$Y = C \cdot F/O$$

where:

- Y = micrograms of material per gram of processed resin
- C = concentration of emissions material in the manifold air (micrograms/L)
- F = delivery flow rate in liters per minute (700 liters per minute for manifold, 10 liters per minute for hopper)
- O = resin throughput in grams/minute.

The emission factors in units of micrograms/gram (ppm[wt/wt]) are equivalent to pounds of emissions per million pounds of processed resin.

## RESULTS AND DISCUSSION

### Accuracy and Precision of Emission Measurements

The Manifold Spiking Tests (described earlier) provided a measure of accuracy for the emission factor data. Precision (or relative error) of the data was measured by calculating the relative percent difference (RPD) of the duplicate analysis results. Based on these evaluations, the emission factors generated in this project are, on a conservative basis, expected to be within ±30 percent of the actual values. The accuracy and precision results are further discussed below.

**Accuracy.** Benzene-d<sub>6</sub> served as the surrogate compound for the hydrocarbon method (i.e., canister sampling and GC/FID analysis). Formaldehyde represented the compounds analyzed with the carbonyl species method, whereas all three acids were used to validate the organic acid method. Spike recoveries for these substances range from 95% to 130% and are presented in Table 5.

**Precision.** By definition, the relative percent difference (RPD) for duplicate measurements is determined by calculating the absolute difference of the two results, multiplying by 100, and then dividing by the mean. For this study, duplicate samples were collected with the following sampling/analytical methods, light and heavy hydrocarbons (canisters), organic acids (KOH coated filters) and aldehydes/ketones (DNPH impregnated cartridges). Duplicate sampling was not carried out for particulates. Additionally, repeated extrusion runs at one or more of the target die head melt temperatures were carried out for all three types of resins. As a result, there are both within-run and between-run components of precisions.

The within-run precision was calculated as follows. For every analyte which contained duplicate values, a RPD was calculated. An average RPD was then calculated for all analytes within a method. Table 6 shows these within-run average RPD values for each method, along with the range of individual results.

The between-run precision was calculated as follows. For the repeated extrusion test runs, a RPD value was calculated for each analyte across each repeated extrusion run. An average RPD was then calculated for all analytes within a method. Table 6 shows these between-run average RPD values for each method, along with the range of the individual results.

### Emission Factor Results

The emission factor results are presented in Table 7. Overall, VOCs and particulates for all three test resins had much higher emission factors than the oxygenates. VOC emissions for polyethylene ranged from 8 to 157 ppm (wt/wt), while particulates were as high as 242 ppm (wt/wt). The higher test temperatures generally produced higher emission factors, as illustrated for VOCs and particulates in Figures 5 and 6, respectively.

As discussed in the experimental section, two different methods were used to measure VOC emissions. One was the Beckman 402 Hydrocarbon Analyzer which continually analyzed the air emission stream throughout the run and provided a direct reading of all (VOC) substances responding to the flame ionization detector. The other method utilized an evacuated canister for sample collection and gas chromatography for analysis. With this method, total VOCs are determined by summing the Heavy Hydrocarbons and Light Hydrocarbons results.

As can be seen in Table 7, the results between the two methods do not always correlate. For LDPE, the Beckman 402 results are about twice as high as the sum of the HHC and LHC results. However, for LLDPE, the VOC emissions at 355 °F and 395 °F indicate the opposite situation. There are a number of possible explanations for these discrepancies as the techniques are inherently different, but that discussion is beyond the scope of this paper. However, as a conservative measure, it is recommended that the higher result of either VOC method be used when estimating emission quantities.

One advantage of the canister method is that it can provide emission data on total VOCs as well as individual compounds. Based on visual observation of the VOC

chromatograms, the VOC measurements were due to the additive response of many individual compounds. Even at the highest test temperature used for each resin, the majority of individual VOCs were below 1 ppm (wt/wt), and no single VOC compound exceeded 6 ppm (wt/wt). Those that exceeded 1 ppm (wt/wt) were aliphatic hydrocarbons in the C<sub>6</sub> to C<sub>16</sub> range. Hexane, which is listed as a Hazardous Air Pollutant, was present in some of the resin emissions, but never at levels exceeding 1 ppm (wt/wt).

In almost all cases, oxygenates were either present in the emission at levels less than 1 ppm (wt/wt), or they were not detected at all. The exception is LDPE processed at 600 °F. At this temperature, formic acid, formaldehyde, methyl ethyl ketone (or butyraldehyde), acetaldehyde, propionaldehyde, and acetic acid had emission factors of more than 1 ppm (wt/wt). Formic acid was the highest oxygenated compound detected at 12 ppm (wt/wt). The oxygenated compounds on the HAPs list are designated as such in Table 7.

### Comparison of VOC Quantities from Hopper and Die Areas

VOCs were measured from both potential emission sources to determine "total" VOCs released during extrusion. The results of this study indicate that the die area of the extruder was the predominant source of VOC emissions. For all three test resins, the emissions collected in the hopper area represent less than 2% of the total VOCs. Hence, the contribution from the hopper area was not included in the calculation of emission factors.

### Predicting Emissions Within Experimental Temperature Range

The data in Table 7 were reduced to the following equation that predicts the level of emissions at a specific extrusion temperature:

$$Y = (M * T) + C,$$

where:

Y = emissions in pounds per million pounds of processed resin

T = melt temperature in °F

M and C constants are shown in Table 8 for each analyte.

**Table 6.** Within-run and between-run precision.

Method	Within-Run RPD <sup>a</sup> (%)	Range of Individual Results ppm		Between-Run RPD <sup>a</sup> (%)	Range of Individual Results ppm	
		Low	High		Low	High
Heavy Hydrocarbons	16.5 (n <sup>b</sup> = 57)	0.02	6.02	9.6 (n = 40)	0.08	5.94
Light Hydrocarbons	8.5 (n = 27)	0.01	1.66	13.0 (n = 12)	0.01	1.66
Organic Acids	26.9 (n = 5)	0.19	15.6	12.6 (n = 2)	2.0	14.7
Aldehydes/Ketones	14.9 (n = 59)	0.02	8.37	24.7 (n = 23)	0.01	8.32
Particulates	ND <sup>c</sup>	ND <sup>c</sup>	ND <sup>c</sup>	20.9 (n = 4)	22.5	245.1

<sup>a</sup>RPD = Relative percent difference

<sup>b</sup>n = Number of measurements.

<sup>c</sup>ND = Not determined.

**Table 7.** Summary of polyethylene emission factors by resin type (lbs/million lbs).

Resin Type	LDPE			LLDPE		HDPE		
	Extrusion Coating			Blown Film		Blow Molding		
Melt Temperature (°F)	500	600	355	395	450	500	380	430
<b>Particulates</b>	30.9	242.2	2.4	21.7	24.7	59.9	19.6	26.6
<b>Volatile Organic Compounds</b>								
Beckman 402 - THC <sup>a</sup>	35.3	157.4	8.0	9.3	14.2	19.9	21.1	30.7
<b>Heavy Hydrocarbons (HHC)<sup>b</sup></b>	17.0	76.6	13.9	15.3	15.4	21.3	25.0	38.5
<b>Light Hydrocarbons (LHC)</b>								
Ethane	0.09	1.21	0.02	0.03	0.03	0.04	0.02	0.02
Ethylene	0.05	1.58	0.01	0.03	0.01	0.02	0.02	0.01
Propylene	0.02	0.38	<0.01	0.01	<0.01	<0.01	0.01	<0.01
<b>Aldehydes</b>								
Formaldehyde <sup>c</sup>	0.10	8.11	0.09	0.04	0.14	0.20	0.06	0.06
Acrolein <sup>c</sup>	<0.01	0.07	<0.02	<0.02	<0.02	<0.02	<0.02	<0.02
Acetaldehyde <sup>c</sup>	0.12	4.43	0.03	0.03	0.09	0.16	0.04	0.05
Propionaldehyde <sup>c</sup>	0.07	3.26	<0.02	<0.02	0.02	0.05	<0.02	0.02
<b>Ketones</b>								
Acetone	0.02	0.04	0.08	0.07	0.08	0.08	0.02	0.03
Methyl ethyl ketone <sup>c</sup>	0.10	5.25	<0.02	<0.02	0.02	0.04	0.05	0.02
<b>Organic acids</b>								
Formic acid	0.34	12.3	<0.17	<0.17	<0.17	<0.17	<0.17	<0.17
Acetic acid	<0.17	2.00	<0.17	<0.17	<0.17	<0.17	<0.17	<0.17
Acrylic acid <sup>c</sup>	<0.02	<0.02	<0.02	<0.02	<0.02	<0.02	<0.02	<0.02

<sup>a</sup> THC = Total hydrocarbons.

<sup>b</sup> HHCs are predominantly comprised of C<sub>4</sub> - C<sub>16</sub> alkanes and alkenes.

<sup>c</sup> Hazardous air pollutants under the Clean Air Act. Methyl ethyl ketone is indistinguishable from butyraldehyde in the HPLC analysis; therefore, any mass reported may be due to the presence of either or both substances.

These constants were calculated using the data for each run; in some cases duplicate runs were made at the same temperature (see Table 2). In those cases where duplicate runs were made the average analyte emissions are reported in Table 7.

Inserting the melt temperature (°F) into the equation will provide an estimate of the number of pounds of emissions per one million pounds of processed polymer. This equation is only valid within the temperature ranges used in this study and is not recommended for predicting emissions for temperatures outside this range.

#### Significance of Emission Factors from SPI Study

This study provides emission data collected during extrusion of polyethylene under specific operating conditions. The emission factors developed in this study are two orders of magnitude lower than those reported in an earlier EPA document.<sup>2</sup>

The significance of this data becomes apparent when placed in the context of the 1990 Clean Air Amendment's definition of "major" source for VOC emissions. Categorization of an emission source as a "major" source subjects it to more stringent permitting requirements. The definition of a "major" source varies with the severity of the ozone nonattainment situation of the area where the source is located. The current VOC emission limits are 10 tons/year for an emission source within an extreme ozone nonattainment classification, 25 tons/year for a

source in the severe classification, and 50 tons/year for a source in the serious classification. Currently, the only extreme nonattainment area in the U.S. is the Los Angeles area.

The utility of this data can be illustrated in the following example. Based on the emissions data and equations developed in this effort, a processor with equipment similar to that used in this study can extrude up to 125 million pounds of LDPE, 950 million pounds of LLDPE, or 510 million pounds of HDPE using the maximum temperatures employed in this study without exceeding the 10-ton/year limit for an extreme ozone nonattainment area.

Although this information is clearly useful, the reader must realize that these emission factors reflect the quantities obtained from the specific resins and under the conditions and with the specific equipment used in this study. Before using the data in this paper to estimate emissions, one must consider a number of other parameters that may impact the type and quantity of emissions as discussed in the introduction section.

#### SUMMARY OF FINDINGS

- The emission entrainment, collection and analysis techniques employed in this study provided a representative, accurate and precise method for determining air emissions evolved from thermal extrusion of selected types of LDPE, LLDPE and HDPE on a pilot scale extruder with a 1.5 inch screw fitted with an eight-strand die.

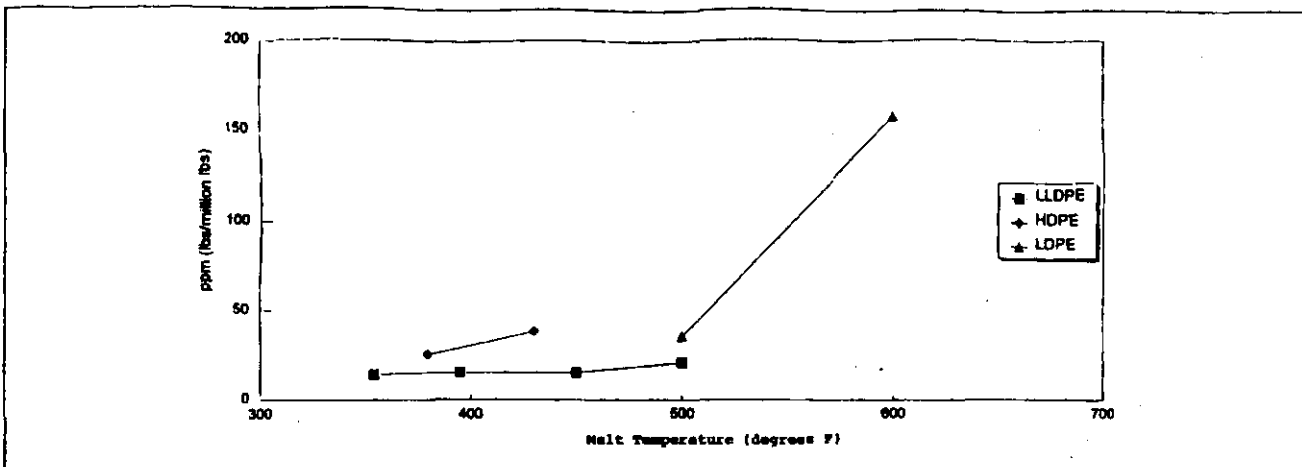

**Figure 5.** Emissions of VOCs from polyethylene resin composites versus temperature. Note: The equation has not been validated beyond the temperature ranges used in this study. Particular care should be taken when using the equation above the upper test temperature for each resin. Use of this equation to predict emissions above the upper range of this study is not recommended.

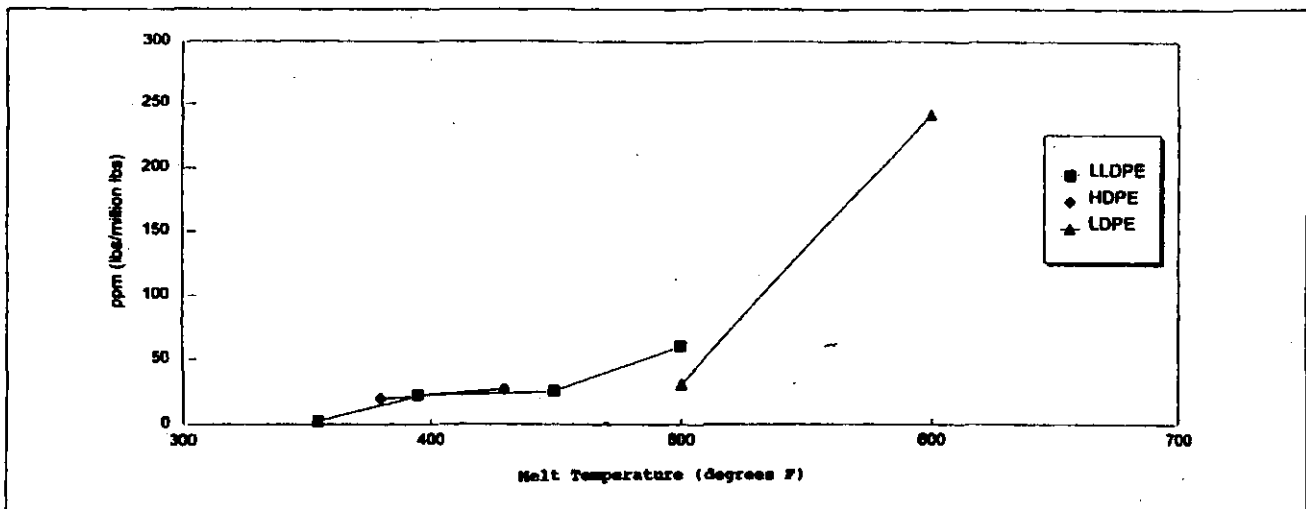

**Figure 6.** Particulate emissions from polyethylene resin composites versus temperature. Note: The equation has not been validated beyond the temperature ranges used in this study. Particular care should be taken when using the equation above the upper test temperature for each resin. Use of this equation to predict emissions above the upper range of this study is not recommended.

- For all three resins studied, the major emission components were particulate matter and VOCs. VOC emissions for polyethylene ranged from 8 to 157 ppm (wt/wt), which is equivalent to pounds of emissions per million pounds of processed resin. Particulates ranged as high as 242 ppm (wt/wt). Lower emission levels were measured for the specific aldehydes, ketones and organic acids monitored in this study. VOC emissions measured in this study from polyethylene are two orders of magnitude lower than estimates reported in a 1978 EPA report.
- According to The Clean Air Act Amendments of 1990, a major emission source of VOCs is one that has the potential to emit 10 tons per year of VOC emissions in an extreme ozone nonattainment area. If a processor were to process the same resins and use the same equipment and conditions employed in this study, a

total of 125 million pounds of LDPE, 950 million pounds of LLDPE, or 510 million pounds of HDPE could be processed without exceeding the 10-ton/year limit. (Note that the processor must also account for emissions from all additional materials used in the operation and any other activities in the plant.)

- The predominant emission source for VOCs was the die head of the extruder. The emissions from the hopper area contributed 2% or less of the total emissions.
- In general, higher melt temperatures produced higher emissions factors for a given resin.
- Equations for predicting the emissions from LDPE, LLDPE and HDPE as a function of temperature were developed for total VOCs, particulates and the selected oxygenated compounds. Those using these equations must realize that they reflect the emissions generated for the specific resins and conditions. The equations

**Table 8.** Coefficients for equation predicting emission levels ( $y = mt+c$ , where "t" is extrusion temperature (°F) and "y" is emission quantity in lbs per million lbs of resin).

LDPE	Temperature Range	M (slope)	C (y Intercept)
VOCs (402 method)	500 - 600 °F	1.221	-575.2
Particulates	500 - 600 °F	2.112	-1025
Formaldehyde	500 - 600 °F	0.0801	-39.9
Acetaldehyde	500 - 600 °F	0.0433	-21.5
Propionaldehyde	500 - 600 °F	0.0323	-16.1
Methyl Ethyl Ketone	500 - 600 °F	0.0516	-25.7
Acetone	500 - 600 °F	0.00015	-0.055
Formic Acid	500 - 600 °F	0.132	-65.4
Crotonaldehyde was sometimes detected at a maximum of 0.2µg/gm. Compounds that were only detected at higher temperature: Acrolein and Acetic Acid			
LLDPE VOCs (speciation method)	355 - 500 °F	0.046	-3
Particulates	355 - 500 °F	0.3923	-136.9
Formaldehyde	355 - 500 °F	0.00096	-0.281
Acetaldehyde	355 - 500 °F	0.0010	-0.357
Compound that was constant over temperature range: Acetone. Compounds that were only detected at higher temperature: Propionaldehyde, Methyl Ethyl Ketone			
HDPE VOCs (speciation method)	380 - 430 °F	0.27	-77.6
Particulates	380 - 430 °F	0.141	-34.0
Compounds that were constant over temperature range: Formaldehyde, Acetaldehyde, Acetone, Methyl Ethyl Ketone			

Note: The equation has not been validated beyond the temperature ranges used in this study. Particular care should be taken when using the equation above the upper test temperature for each resin. Use of this equation to predict emissions above the upper range of this study is not recommended.

have not been validated beyond the temperature ranges used in this study and their use above these ranges is not recommended.

- In some cases the emission factors determined in this study may overestimate or underestimate emissions from a particular process. Professional judgment and conservative measures must be exercised as necessary when using the data for estimating emission quantities.

#### ACKNOWLEDGMENTS

We gratefully acknowledge the technical assistance provided by D.L. Smith, R.N. Smith, G.W. Keigley, J. Frye, T.M. Vinci and M.J. Brooker. We are especially indebted to M.A. Roberts for her help in preparing the tables. Work was funded through The Society of the Plastics Industry, Inc. Companies providing financial support and resin materials are: Chevron Chemical Company, The Dow Chemical Company, DuPont Canada Inc., Exxon Chemical Company, Lyondell Technical Center, Mobil Chemical Company, Novacor Chemical LTD., Quantum Chemical Company, Union Carbide Corporation.

#### REFERENCES

- Hoff, A.; Jacobsson, S. "Thermo-oxidative degradation of low density polyethylene close to industrial processing conditions," *Journal of Applied Polymer Science* 1981, 26, 3409-3423, 1981.
- Hughes, T.W.; Boland, R.F.; Rinaldi, G.M. of Monsanto Research Corporation. "Source Assessment: Plastics Processing, State of the Art," EPA-600/2-78-004C, March 1978, pp. 27-28.
- EPA Document EPA 450/4-90-003. "Airs Facility Subsystem Source Classification Codes and Emission Factor Listing for Criteria Air Pollutants," EPA, March 1990.
- Battelle. Sampling and Analysis of Emissions Evolved During Thermal Processing of Polyethylene Resin Composites (LDPE, LLDPE, HDPE Resins); Final Report to the Society of the Plastics Industry, Inc., July 1994.
- Spicer, C.W.; Holdren, M.W.; Miller, S.E.; Smith, D.L.; Smith, R.N.; Kuhlman, M. R.; Hughes, D. P. Aircraft Emissions Characterization: TF41-A2, TF30-P103, TF30-P109 Engines. Report ESL-TR-87-27, Tyndall AFB, FL, March 1988.
- Spicer, C.W.; Holdren, M.W.; Miller, S.E.; Smith, D.L.; Smith, R.N.; Hughes, D.P. Aircraft Emissions Characterization. Report ESL-TR-87-63, Tyndall AFB, FL, March 1988.
- Code of Federal Regulations (CFR)*, title 40, part 86, section 111, July 1, 1994.
- Code of Federal Regulations (CFR)*, title 40, part 60, Appendix A, July, 1994.
- Sampling and Measurement of Formic Acid in Methanol-Vehicle Exhaust, Battelle Final Report to Coordinating Research Council, November 1991. Available from NTIS as PB92-160100.
- Compendium of Methods for the Determination of Toxic Organic Compounds in Ambient Air, U.S. Environmental Protection Agency, June 1988. Available from NTIS as PB90-127374.
- Silvon, L.E.; Kenny, D.V.; Severance, R.A. United States Patent #4,982,097, January 1991.

#### About the Authors

A. Barlow, Ph.D., is the Product Steward for Quantum Chemical Company; Philip J. Garrison, Ph.D., is a Research Scientist at Lyondell Technical Center; Michael W. Holdren is a Senior Research Scientist, and Denise A. Contos is a Program Manager, both at Battelle Memorial Institute; Brian Janke is presently an Industrial Hygienist at Exxon Research and Engineering Co.; and Lynne R. Harris (corresponding author) is Technical Director with the Society of the Plastics Industry, Inc., 1275 K Street, N.W., Suite 400, Washington, D.C. 20005.

## Development of Emission Factors for Polyamide Processing

**George Kriek and Nelson Lazear**  
*Bayer Corporation, Pittsburgh, Pennsylvania*

**Verne Rhodes**  
*Product Regulatory Services, Gulf Breeze, Florida*

**Joe Barnes**  
*Honeywell Engineered Applications & Solutions, Hopewell, Virginia*

**John Bollmeier**  
*DuPont Engineering Polymers, Wilmington, Delaware*

**Jane Chen Chuang, Michael W. Holdren, and Anthony S. Wisbith**  
*Battelle, Columbus, Ohio*

**Jennifer Hayward**  
*Society of the Plastics Industry, Inc., Washington, DC*

**Diane Pietrzyk**  
*BASF Corporation, Wyandotte, Michigan*

### **ABSTRACT**

Emission factors for selected volatile organic compounds (VOCs) and particulate material were developed during processing of commercial grades of polyamide 6, polyamide 66, and polyamide 66/6 resins. A small commercial-type extruder was used, and melt temperatures ranged from 475 to 550 °F. An emission factor was calculated for each substance measured and is reported as pounds released to the atmosphere per million pounds of polymer resin

processed. Scaled to production volumes, these emission factors can be used by processors to estimate emission quantities from similar polyamide extrusion operations.

### **INTRODUCTION**

As compliance with air pollution regulations has increased in complexity over the last 15-20 years, small businesses that had never before been affected are now being involved in permit and compliance issues. While the U.S. Environmental Protection Agency (EPA) has continued to develop and refine sections of its compendium of emission factors contained in AP-42, much of the data are outdated, particularly data related to plastics. As a result of the evolving regulations, plastic processing companies are faced with the task of establishing an "emissions inventory" for the chemicals generated and released by their production processes. The chemicals considered in this study are those considered to be volatile organic compounds (VOCs) and those that are on EPA's original list of 189 hazardous air

### **IMPLICATIONS**

This study provides quantitative emissions data collected while processing seven types of polyamide blends. These data are directly related to production volumes and can be used as reference points to estimate emissions from similar polyamide resins processed on similar equipment. The compounds chosen for analysis and subsequent emission factor calculations were the ones the authors deemed most likely to be of significance.

pollutants (HAPs). When applying for a state operating permit, processing companies are required to establish a baseline of their potential emissions.<sup>1</sup>

In response to the needs of the plastic industry, the Society of the Plastics Industry, Inc. (SPI) organized a study to determine the emission factors for extruding polyamide homopolymers, copolymers, and blends. Sponsored by five major resin producers, the study was performed at Battelle, Columbus, OH. This work follows previous SPI/Battelle studies on the emissions of acrylonitrile-butadiene-styrene,<sup>2</sup> polyethylene,<sup>3</sup> ethylene-vinyl acrylate and ethylene-methyl acrylate copolymers,<sup>4</sup> and polypropylene.<sup>5</sup>

As in these previous studies, a body of literature references exists concerning emissions from polyamides, most of them using static small-scale procedures.<sup>6-8</sup> These procedures may not accurately simulate the temperature and oxygen exposure conditions typical of extrusion processing. The static procedures might expose the polyamide to temperatures greater than or less than the typical extrusion temperature, and for an extended period of time. They also continuously expose the polyamide to atmospheric oxygen. During extrusion, the polyamide is molten for a few minutes at most, and the equipment is designed to force air out of contact with the melt in the barrel. Hot polyamide would be in contact with oxygen only briefly as it exits the die. In light of these differences, the accuracy of data obtained from static tests may limit their usefulness in predicting emissions during polyamide processing.

Greater accuracy would, of course, be possible by measuring emissions from an actual production extruder. Since operating parameters can influence the type and quantity of emissions, the greatest accuracy would be achieved by studying each process. Parameters that can influence emissions include extruder size and type, melt temperature, extrusion rate, ratio of air-exposed surface to the volume of the extrudate, and shear effects due to screw design. Variables associated with the material being extruded can also affect emissions, that is, resin type, age of the resin, additive packages, and heat history of any recycled resin. It would be a daunting task to design and implement emission studies for all combinations of extrusion variables.<sup>9</sup>

To strike a balance between the inapplicability of static tests and the complexity of measuring each process, the SPI and major polyamide producers initiated work to develop baseline emission factors for polyamide processing under conditions that would provide reasonable reference data for similar processing operations. The seven resin types were evaluated and included a polyamide 66 homopolymer, a low-caprolactam polyamide 6 homopolymer, a polyamide 66/6 copolymer, an ethylene propylene diene monomer (EPDM)-toughened polyamide 66, a toughened polyamide 6, a mixture of polyamide 66 and polyamide 66/6 flame

retarded with melamine, and a polyamide 66/6 flame retarded with Dechlorane Plus. The test samples were mixtures of commercial resins obtained from the sponsoring companies. Table 1 lists the resins used, the additives present, the chemical analytes, and the temperatures of the tests. The selected analytes included PM, total VOCs, CO, nitrogenous compounds (ammonia, hydrogen cyanide, nitrogen dioxide, and caprolactam), and compounds released from additives (styrene and maleic anhydride). These compounds are of interest because they are residual monomers, they are on the HAPs list, or they are the expected thermal and thermo-oxidative breakdown products of the extruded polymers.

## EXPERIMENTAL

### Resin-Blending Procedure

Equal portions of each contributed resin were homogeneously mixed in 10-gal metal cans to form a composite blend immediately prior to the test run. Each container was filled to approximately two-thirds of capacity, sealed under dry nitrogen atmosphere, and then thoroughly blended by rotation on an automated can-rolling device. The resins were received in sealed foil-lined bags in the dried condition. They were directly transferred from the bags to the metal cans with no additional drying.

### Experimental Process Conditions

An HPM Corp. 1.5-in., 30:1 L/D, 15-hp plastic extruder was used to process the resins. The extruder is capable of ~60 lb/hr throughput and 800 °F (maximum) barrel temperatures for the three heat zones. A special fabricated

Table 1. Test plan for polyamide extrusions.

Run No.	Description	Additives <sup>a</sup>	Analytes <sup>b</sup>	Targeted Melt Temperature
1	General PA66	D,E,F	1,2,3,4,5,6	550 °F
2	General PA6, low caprolactam	E	1,2,3,4,5,6,7	520 °F
3	Copolymer PA66/6	D,F	1,2,3,4,5,6,7	475 °F
4	EPDM-toughened PA66	A,F	1,2,3,4,5,6,8	550 °F
5	Toughened PA6	A,D	1,2,3,4,5,6,7,8,9	550 °F
6	PA66 or PA66/6 flame-retarded with melamine	C,D,E,F,G	1,2,3,4,5,6,7	520 °F
7	PA66/6 flame-retarded with Dechlorane Plus	B,E,F,G	1,2,3,4,5,6,7	480 °F

<sup>a</sup>Generic additives: A = toughener; B = Dechlorane Plus flame retardant; C = melamine flame retardant; D = processing aid; E = release agent; F = lubricant; G = colorant. <sup>b</sup>Possible emissions: 1 = ammonia; 2 = hydrogen cyanide; 3 = total VOCs; 4 = total particulates; 5 = carbon monoxide; 6 = nitrogen oxides; 7 = caprolactam; 8 = maleic anhydride; 9 = styrene.

screw based on design parameters provided by SPI committee members was constructed for this study, as shown in Figure 1. The compression ratio of the single stage screw was 2.4:1. An eight-strand die head used in previous SPI-sponsored emissions studies was used for the polyamide program (see Figure 2). The die head was cleaned and inspected. The holes were reamed to 3/16-in. diameter and the surface was polished.

Each polyamide mixture was initially extruded for approximately 30–60 min prior to sampling. During this time, the total VOCs were monitored by the online VIG Industries Model 20 total HC analyzer. Once the target die head temperature was reached and the extruder was set to the target RPM (75% of full scale), the VOC analyzer output would indicate stable readings (that is,  $\pm 10\%$  drift over a 10-min period). At this time, a 20-min test run was initiated. The 20-min sampling time was sufficient to achieve a target detection level of 1  $\mu\text{g}$  of chemical component per 1 g of processed resin. The only exception was  $\text{NH}_3$ , in which a detection level of 4.7  $\mu\text{g/g}$  was obtained. Operating parameters were recorded initially and at 5-min intervals during each sampling run. Immediately after each test run, a second run was started using the same operating parameters. The duplicate runs were made to assess sampling and analytical precision. Based on previous resin studies,<sup>2,5</sup> a combined sampling and analytical precision of  $\pm 30\%$  relative difference was expected.

**Die Head Emissions Collection**

A diagram of the emission enclosure apparatus is shown in Figure 3. The enclosure was positioned and sealed

around the extrusion head. A door at the front of the enclosure allowed the operator to periodically check the flow characteristics of the extruded resin. An 8 x 8-in. opening at the bottom of the enclosure allowed the extruded resin to drop into a weighing pan. Emissions were entrained in preconditioned air (i.e., purified through a charcoal filter). Incoming filtered air was preset at a flow of 180 L/min using the variable flow blower. This flow was directed through the laminar flow head assembly and across the extrusion die head. The variable flow blower on the receiving side of the manifold system was adjusted to at least match the 180 L/min inlet flow. Additional flow from the sampling equipment resulted in an approximately 10% greater flow into the receiving end of the sampling manifold. This excess flow was necessary to assure that all air within the die head area passed through that zone and into the sampling manifold. Smoke tubes were used just before the test runs to confirm efficient transfer of the emissions. These tubes were placed near the 8 x 8-in. opening at the bottom of the enclosure, and visual inspection indicated that the smoke was indeed drawn up into the enclosure and toward the sampling manifold.

The manifold was equipped with multiple ports for connecting the various sampling devices. Each port was a 0.25-in. o.d. tube that protruded 1 in. into the airstream. For the collection of particulate material, the manifold was also equipped with a 4-in. filter holder assembly as well as an inline stainless steel probe (0.25-in. i.d.) connected to a 47-mm filter pack.

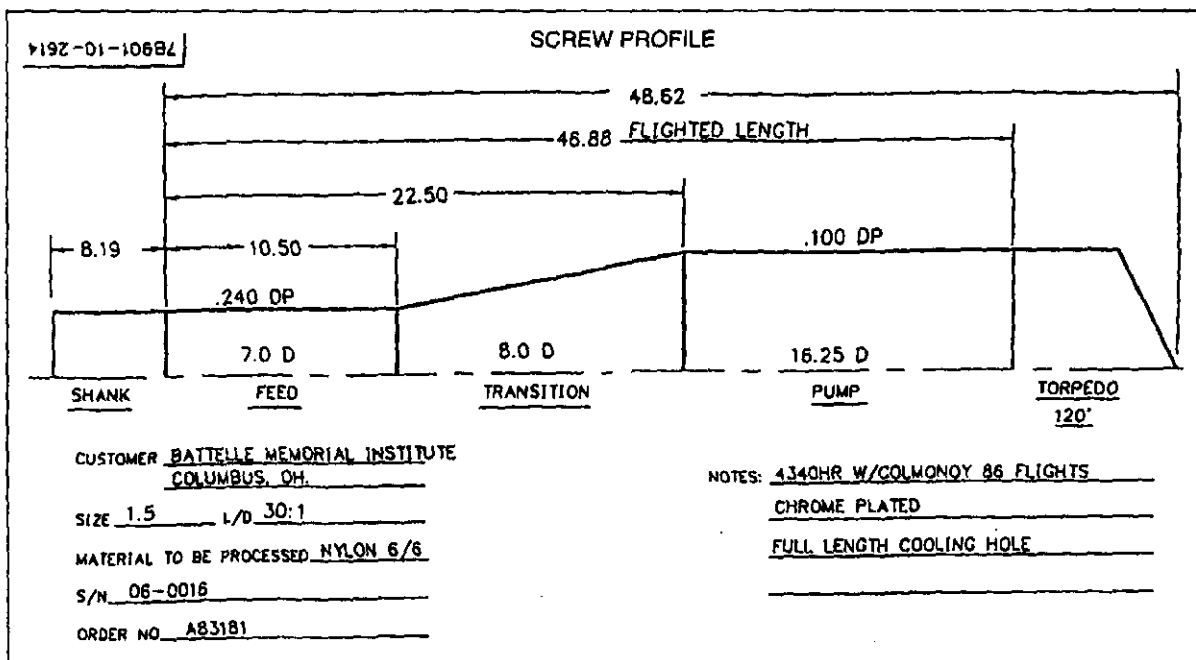
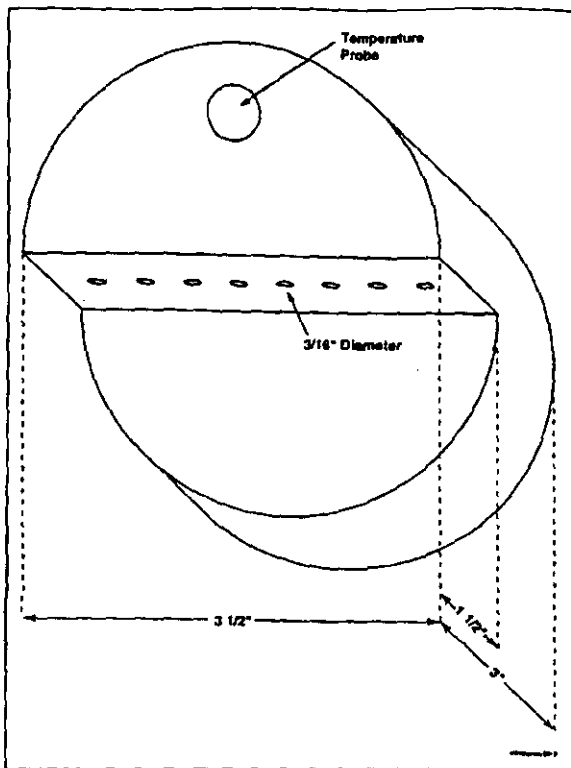

Figure 1. Screw profile (HPM Corp.).





**Figure 2.** Extruder strand die head used in polyamide emissions testing program.

**Sampling and Analysis Methods**

The methods employed for characterizing the emissions from the resin extrusion process are summarized in the following sections. Detailed information is discussed elsewhere.<sup>10</sup>

**Ammonia.** Samples for the determination of  $\text{NH}_3$  concentrations in the exhaust effluent were collected and

analyzed in accordance to National Institute of Safety and Health (NIOSH) Method No. S347. A sampling flow rate of 200 mL/min (20-min test run) was drawn through a glass tube containing  $\text{H}_2\text{SO}_4$ -treated silica gel to trap  $\text{NH}_3$  vapors. The sampling tube was connected in series to a prefilter to collect particulate  $\text{NH}_4^+$  salts. Ammonia was desorbed from the silica gel with 0.1 N  $\text{H}_2\text{SO}_4$ , and the sample was analyzed using an  $\text{NH}_3$ -specific electrode. The method detection limit under the above sampling conditions was 5.0  $\mu\text{g/L}$ .

**Hydrogen Cyanide.** Samples for the determination of hydrogen cyanide concentrations in the exhaust effluent were collected and analyzed in accordance to NIOSH Method No. 7904. A sampling flow rate of 1000 mL/min was drawn through a prefilter and then through two midget bubblers each containing a 10-mL solution of 0.1 N KOH. The bubbler solutions were analyzed using a cyanide ion-specific electrode. (The filter was not extracted or analyzed.) The method detection limit was 0.2  $\mu\text{g/L}$ .

**Total VOCs.** A VIG Industries Model 20 total HC analyzer equipped with a hydrogen flame ionization detector (HFID) was used to continuously monitor the VOC content of the exhaust effluent. A heated sample line (300 °F) was connected to the extruder sample manifold, and sample flow was maintained at 2 L/min. The analyzer was calibrated at the beginning of each test day against a National Institute of Standards and Technology (NIST)-traceable reference cylinder containing a mixture of propane in ultra-zero air (10  $\mu\text{g/L}$ ). Linearity was demonstrated prior to the test runs by challenging the analyzer calibration standards of 10, 180, and 1800  $\mu\text{g/L}$  of propane. The method detection limit was 0.5  $\mu\text{g/L}$ . Guidelines from EPA

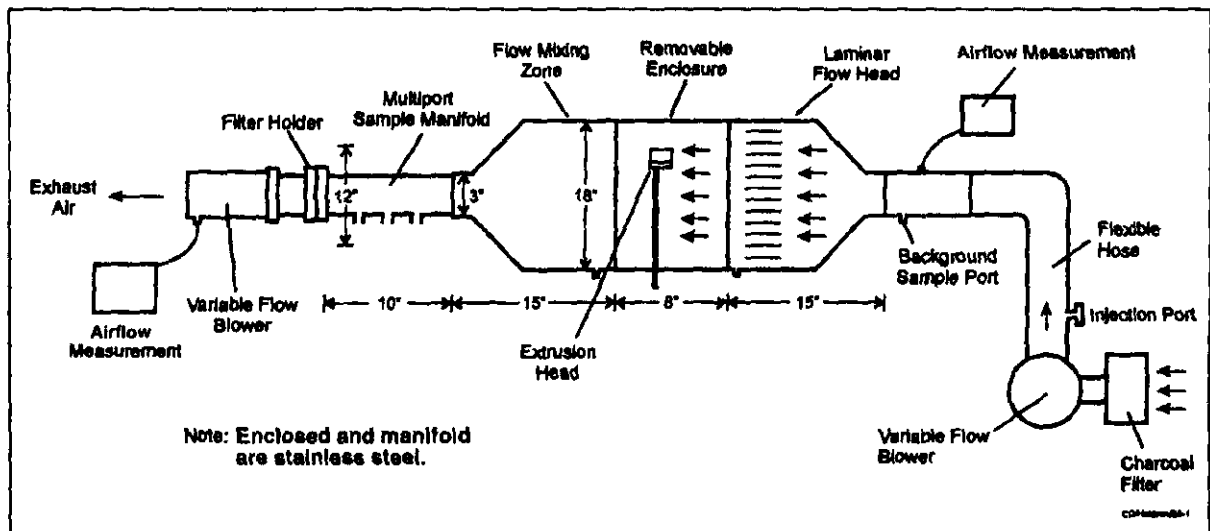

**Figure 3.** Emission enclosure apparatus.

Method 25A were followed. With this method, alkanes, alkenes, and aromatic HCs would respond to the HFID on an equal per-carbon basis. Other volatile organic compounds will also respond to the HFID, but on a less than equal per-carbon basis (e.g., carbonyl species).

**Total PM.** The concentration of particulate emissions was determined by passing a sample of the exhaust effluent through a pre-weighed filter and then conducting a gravimetric analysis of the sampled filter. The original procedure called for the insertion of the preweighed filter (4-in. diameter) into the exhaust port of the sampling manifold. The sample volume was determined from a calibrated orifice and a magnehelic gauge located on the sample manifold blower. However, after conducting Test 1A, it was realized that the high particulate concentrations emitted during extrusion caused the filter to partially plug, and the flow through the sample manifold dropped significantly during the test run. To alleviate the problem, a 47-mm filter holder equipped with a 0.25-in. i.d. sample probe was added to the sampling manifold in place of the 4-in. filter. The sample probe was positioned in the center of the manifold, and flow through the filter was maintained at a flow rate suitable to assure isokinetic conditions at the probe inlet.

A flow rate of 19 L/min was used during the 20-min test runs. Gravimetric analyses of the filter before and after sampling were carried out in a controlled environmental facility (temperature  $70 \pm 2$  °F, relative humidity  $50 \pm 5\%$ ). The filters were preconditioned to the controlled environment for 24 hr and then weighed. For the above flow rate and sampling time, a method detection limit of 0.5  $\mu\text{g/L}$  was obtained.

**Carbon Monoxide.** Tedlar bags (40-L capacity) were used to collect time-integrated whole air emission samples during the test runs. A pump/mass flow controller assembly was used to draw air from the manifold and into the bag. The flow was set to 1 L/min. Analyses were carried out offline using a Bacharach Sentinel 44 real-time CO monitor equipped with an electrochemical sensor with a linear range from 0 to 1000  $\mu\text{g/L}$ . A single point calibration check was conducted using a NIST calibration cylinder containing CO at 49  $\mu\text{g/L}$ . The instrument's detection limit was 1.0  $\mu\text{g/L}$ .

**Oxides of Nitrogen.** The bags used for CO collection were also analyzed for total  $\text{NO}_x$ . Analyses were carried out with a Monitor Labs 8440  $\text{NO}_x$  real-time monitor equipped with a chemiluminescence detector specifically tuned for nitric oxide (NO). Total  $\text{NO}_x$  were determined by directing sample air through a reducing catalyst bed and then to the detector. The monitor had an operating range from

0 to 5  $\mu\text{g/L}$ . A single point calibration check was conducted with a NIST calibration cylinder containing NO at 1.5  $\mu\text{g/L}$ . The instrument's detection limit was 0.01  $\mu\text{g/L}$ .

**Caprolactam.** XAD-2 (~8 g) adsorbent tubes were used for the collection of caprolactam emissions. XAD-2 cleaning, extraction, and analytical procedures followed guidelines provided in EPA Method TO-13A.<sup>11</sup> Sampling was conducted over a 20-min collection period using a flow rate of 4 L/min. An SKC sampling pump was used to draw sample into the cartridge assembly. After sampling, the XAD-2 assembly was capped and stored in a refrigerator. Analyses of dichloromethane extracts of the cartridges were carried out using a Hewlett Packard 5973 gas chromatographic/mass spectrometric (GC/MS) system configured in the full scanning electron impact mode of operation. Calibration mixtures of caprolactam ranged from 0.1 to 500  $\mu\text{g/L}$ . The instrument's detection limit was 0.05  $\mu\text{g/L}$ .

**Maleic Anhydride.** Samples for the determination of maleic anhydride concentration in the exhaust effluent were collected and analyzed in accordance to Physical & Chemical Analysis Methods (P&CAM) Method 302. A sampling flow rate of 1.5 L/min (20-min test run) was drawn through two midjet bubblers each containing 15 mL of distilled water. (Maleic anhydride was hydrolyzed to maleic acid in the bubbler.) The resulting sample was analyzed by a Waters Model 600E high-pressure liquid chromatograph with a UV detector at 254 nm. Calibration mixtures ranged from 0.1 to 50  $\mu\text{g/L}$ . The method detection limit under the above sampling conditions was 0.05  $\mu\text{g/L}$ .

**Styrene.** The method for the collection and analysis of styrene followed EPA Method TO-14A guidelines.<sup>12</sup> Evacuated SUMMA polished 6-L canisters (100 mtorr) were used to collect whole air samples. Each canister was connected to the sampling manifold, and a 5-min integrated sample was obtained during the latter part of the 20-min collection period. After collection, the canister pressure was recorded and the canister was filled to 5.0 psig with ultra-zero air to facilitate repeated analyses of air from the canister.

A Fisons MD 800 GC system equipped with parallel flame ionization and mass spectrometric detectors (FIDs and MSDs) was used for the analysis of styrene present in the canister samples. The FID was used for styrene quantitation. The MS (full scan mode) was used for peak confirmation. The sample-analyzed volume was 60 mL. With this preconcentrated sample volume, the FID detection level was 0.01  $\mu\text{g/L}$ . Detector calibration was based on instrument response to known concentrations of dilute styrene calibration gas (traceable to NIST calibration cylinders). The

calibration range extended from 0.1 to 1000  $\mu\text{g/L}$ .

## RESULTS AND DISCUSSION

### Verification of Collection Efficiency of Sampling Manifold

Tests were conducted prior to the extrusion runs to verify that 100% of a spiking gas (propane) would be transferred across the emissions entrainment zone if the incoming and outgoing flows were balanced. As mentioned in the experimental section, the incoming flow was preset to 180 L/min. The propane concentration generated at the inlet location was 60 ppm C (measured at background sample port—see Figure 3). As expected, the propane concentration measured in the sampling manifold was a function of the voltage setting on the variable flow blower downstream of the sampling manifold. A calibration curve showing the flow rate through the sampling manifold as a function of pressure drop across the orifice of the variable flow blower is shown in Figure 4. At magnehelic gauge readings below 0.5 in. of water, the total HC analyzer indicated a stable reading of  $60 \pm 2$  ppm C at the connection port in the sampling manifold. As the setting was increased above 0.5 in., the total HC reading dropped to reflect the fact that the sampling manifold flow rate was greater than the incoming flow that was preset to 180 L/min.

#### Total Manifold Flow

The total manifold exhaust flow for the individual test runs was needed for the eventual calculation of emission factors. Table 2 lists the total flows for each test run. The orifice  $\Delta P$  value is the observed reading for each run. From

the experimentally derived regression equation, flow =  $180.69(\Delta P) + 90.79$  ( $R^2 = 0.966$ ) (see Figure 4), a flow rate through the blower could be determined using this  $\Delta P$  value. However, the flow across the orifice was originally calibrated at 75 °F. To correct the flow to the manifold operating temperature of 140 °F, the following flow orifice equation was used:

$$Q_2 = Q_1 \left[ \frac{T_2}{T_1} \right]^{1/2} \quad (1)$$

where  $Q_1$  was the flow rate during test runs,  $Q_2$  was the flow rate at 75 °F,  $T_1$  was the temperature of the exhaust air, and  $T_2$  was the temperature at calibration.

A temperature correction factor of 0.944 was applied to the flow rate during the test runs to determine the flow rate at 75 °F. In addition, the flow rates from the individual sampling components were also needed to obtain a total manifold flow. The total manifold flow for each test run is also shown in Table 2. For all test runs except 1A, the total manifold flow was acceptable and slightly greater than the preset incoming flow rate of 180 L/min. This slight excess flow ensured that all emitted material was efficiently transferred to the collection manifold.

#### Emissions

Emission concentrations ( $\mu\text{g/L}$ ) are likewise summarized in Table 2. Total VOCs were usually the highest emission, ranging from 53 to 202  $\mu\text{g/L}$ . In a few cases, the particulates were also high, up to 185  $\mu\text{g/L}$ . In experiments

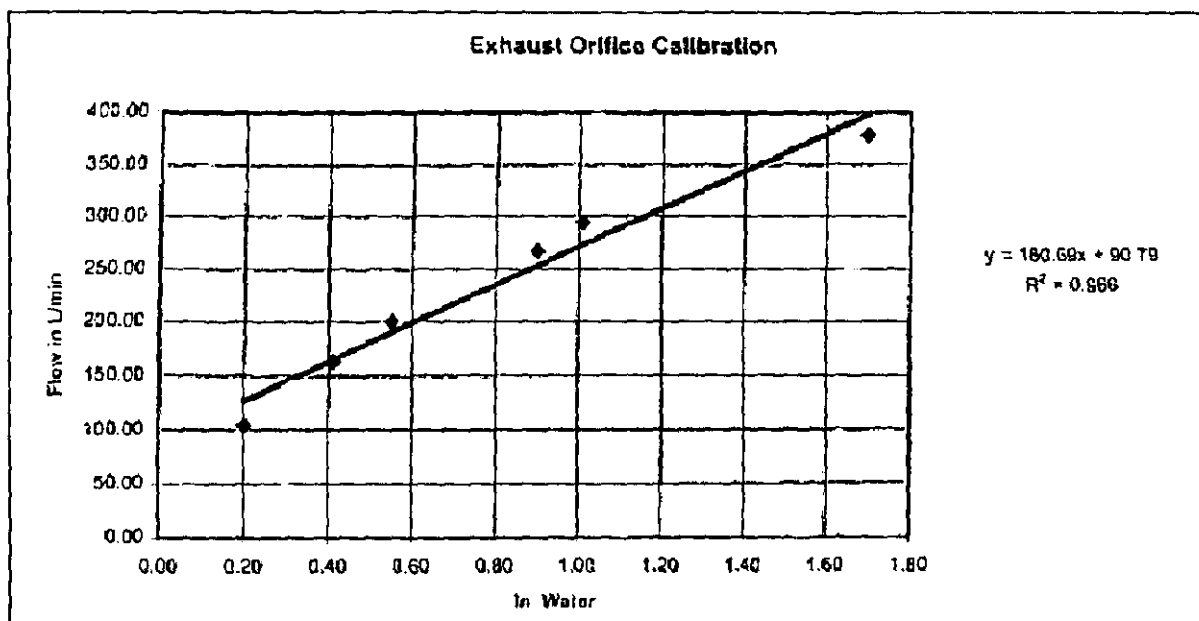

Figure 4. Flow through the manifold as a function of pressure drop across the orifice of the variable speed blower.

with polyamide 6 or its copolymers, caprolactam from the depolymerization reaction was seen in significant quantities, from 24 to 245 µg/L.

Three of the emissions predicted from previous studies<sup>6-8</sup>—ammonia, hydrogen cyanide, and maleic anhydride—were unobserved at the detection limits reported in this study. Carbon monoxide and styrene levels were only significant in rubber-modified polyamide blends. Oxides of nitrogen were only minor emissions. Overall, these results show what manufacturers and processors would have predicted, that is, concentrations significantly below what would have been predicted by previous static tests. The results from this study are ~2 orders of magnitude (100 times) below what would have been predicted from EPA's AP-42 document, which is based on a very outdated survey report.<sup>13</sup>

#### Emission Factors

Emission factors were calculated from measured emission concentration levels shown in Table 2 using the following formula:

$$E = (C \times F)/O \quad (2)$$

where  $E$  was µg of emissions/g of processed resin,  $C$  was the measured concentration of emissions in µg/L,  $F$  was the total manifold flow rate in L/min, and  $O$  was the resin throughput in g/min. Emission factors are summarized in Table 3. Dimensional analysis shows that these emission factors can also be read as lb emissions/million lb resin processed.

Table 2. Summary of extrusion conditions and concentrations of emissions (µg/L).

Test Run No.:	1A	1B	2A	2B	3A	3B	4A	4B	5A	5B	6A	6B	7A	7B
Description:	General PA66		General PA6 Low Caprolactam		Copolymer PA66/6		EPDM-Toughened PA66		Toughened PA6		PA66 or PA66/6 Flame-Retarded with Melamine		PA66/6 Flame-Retarded with Dechlorane	
<b>Extrusion Conditions</b>														
Avg. die head temp. (°F)	550	555	520	520	475	475	550	550	550	550	520	520	500	510
Resin throughput (g/min)	<sup>a</sup>	200	336	331	195	141	218	195	277	286	354	327	377	386
Total manifold flow (L/min)	114	188	216	189	194	194	224	202	234	229	221	234	238	238
<b>Analyte</b>														
Ammonia	<sup>a</sup>	<4.7	<4.7	<4.7	<4.7	<4.7	<4.7	<4.7	<4.7	<4.7	<4.7	<4.7	<4.7	<4.7
Hydrogen cyanide	<sup>a</sup>	<0.15	<0.15	<0.15	<0.15	<0.15	<0.15	<0.15	<0.15	<0.15	<0.15	<0.15	<0.15	<0.15
Total VOCs	<sup>a</sup>	53	101	91	123	112	133	128	202	197	91	85	160	165
Total particulates	<sup>a</sup>	111	37	31	6	2	65	62	32	31	185	129	87	123
Carbon monoxide	<sup>a</sup>	6.1	<1	<1	<1	<1	32.1	36.7	13.8	13.8	<1	<1	<1	<1
Nitrogen oxides	<sup>a</sup>	0.03	0.06	0.03	<0.01	<0.01	0.03	0.04	0.01	0.01	0.05	0.05	0.03	0.03
Caprolactam	<sup>b</sup>	<sup>b</sup>	30.9	23.7	25.6	24.7	<sup>b</sup>	<sup>b</sup>	92.4	64.6	56.4	59.1	>150 <sup>c</sup>	>150 <sup>c</sup>
Maleic anhydride	<sup>a</sup>	<0.05	<sup>b</sup>	<sup>b</sup>	<sup>b</sup>	<sup>b</sup>	<0.05	<0.05	<0.05	<0.05	<sup>b</sup>	<sup>b</sup>	<sup>b</sup>	<sup>b</sup>
Styrene	<sup>a</sup>	<0.01	0.01	0.01	0.01	0.01	0.31	0.28	3.38	3.56	0.03	0.01	0.01	0.01

<sup>a</sup>Not reported because total manifold flow rate is below the required flow of 180 L/min; <sup>b</sup>Measurement of this parameter was not requested—see Table 1; <sup>c</sup>Estimated (flow stoppage in the sampler occurred during the run).

**Table 3.** Summary of extrusion emission factors ( $\mu\text{g/g}$  or  $\text{lb}/\text{million lb}$  polymer processed).

Test Run No.:	1A	1B	2A	2B	3A	3B	4A	4B	5A	5B	6A	6B	7A	7B
Description:	General PA66		General PA6 Low Caprolactam		Copolymer PA66/6		EPDM-Toughened PA66		Toughened PA6		PA66 or PA66/6 Flame-Retarded with Melamine		PA66/6 Flame-Retarded with Dechlorane	
Ammonia	<sup>a</sup>	<4.7	<4.7	<4.7	<4.7	<4.7	<4.7	<4.7	<4.7	<4.7	<4.7	<4.7	<4.7	<4.7
Hydrogen cyanide	<sup>a</sup>	<0.15	<0.15	<0.15	<0.15	<0.15	<0.15	<0.15	<0.15	<0.15	<0.15	<0.15	<0.15	<0.15
Total VOCs	<sup>a</sup>	50	65	52	122	154	137	133	171	158	57	61	101	102
Total particulates	<sup>a</sup>	104	24	18	6	3	67	64	27	25	115	92	55	76
Carbon monoxide	<sup>a</sup>	6	<1	<1	<1	<1	33	38	12	11	<1	<1	<1	<1
Nitrogen oxides	<sup>a</sup>	0.03	0.04	0.02	<0.01	<0.01	0.03	0.04	0.01	0.01	0.04	0.04	0.02	0.02
Caprolactam	<sup>b</sup>	<sup>b</sup>	20	14	25	34	<sup>b</sup>	<sup>b</sup>	78	52	42	42	>100 <sup>c</sup>	>100 <sup>c</sup>
Maleic anhydride	<sup>a</sup>	<0.05	<sup>b</sup>	<sup>b</sup>	<sup>b</sup>	<sup>b</sup>	<0.05	<0.05	<0.05	<0.05	<sup>b</sup>	<sup>b</sup>	<sup>a</sup>	<sup>b</sup>
Styrene	<sup>a</sup>	<0.01	0.01	0.01	0.01	0.01	0.32	0.29	2.9	2.8	0.01	0.01	0.01	0.01

<sup>a</sup>Not reported because total manifold flow rate is below the required flow of 180 L/min; <sup>b</sup>Measurement of this parameter was not requested—see Table 1; <sup>c</sup>Estimated (flow stoppage in the sampler occurred during the run).

compiled by both government and industry. This data was presented at an Air & Waste Management Conference in New Orleans in December 1998.<sup>9</sup> Reprints are available from SPI.

### SUMMARY OF FINDINGS

Total VOCs and total particulate material are the major emissions from the extrusion of typical polyamides. Caprolactam is also a major emission from polyamide 6 and its copolymers. The data collected in this study provide processors with a baseline for estimating emissions generated by polyamide resins that they process under similar conditions. The emission factors reported here may not represent those for other polyamide types or for other methods of processing. Professional judgment and conservative measures must be exercised when using these data for estimating emission quantities.

### REFERENCES

1. Sherman, L.M. Clean-Air Rules Challenge Processors; *Plastics Technol.* 1995, 41 (2), 83-86.
2. Contos, D.A.; Holdren, M.W.; Smith, D.L.; Brooke, R.C.; Rhodes, V.L.; Rainey, M.L. Sampling and Analysis of Volatile Organic Compounds Evolved during Thermal Processing of Acrylonitrile Butadiene Styrene Composite Resins; *J. Air & Waste Manage. Assoc.* 1995, 45, 686-694.
3. Barlow, A.; Contos, D.; Holdren, M.; Garrison, P.; Harris, L.; Janke, B. Development of Emission Factors for Polyethylene Processing; *J. Air & Waste Manage. Assoc.* 1996, 46, 569-580.
4. Barlow, A.; Moss, P.; Parker, E.; Schroer, T.; Holdren, M.; Adams, K. Development of Emission Factors for Ethylene-Vinyl Acetate and Ethylene-Methyl Acrylate Copolymer Processing; *J. Air & Waste Manage. Assoc.* 1997, 47, 1111-1118.
5. Adams, K.; Bankston, J.; Barlow, A.; Holdren, M.; Marchesani, V.; Meyer, J. Development of Emission Factors for Polypropylene Processing; *J. Air & Waste Manage. Assoc.* 1999, 49, 49-56.
6. Braun, E.; Levtn, B. Nylons: A Review of the Literature on Products of Combustion and Toxicity; *Fire Mater.* 1987, 11, 71-88.
7. Patel, S.; Xanthos, M. Volatile Emissions during Thermoplastics Processing—A Review; *Adv. Polym. Technol.* 1995, 14 (1), 67-77.
8. Jellinek, H.; Das, A. HCN Evolution during Thermal-Oxidative Degradation of Nylon 66 and Polyacrylonitrile; *J. Polym. Sci., Polym. Chem. Ed.* 1978, 16, 2715-2719.

9. Rhodes, V.L.; Crawford, J.; Toner, H.P. Emission Factors for Plastics Processing. In *Proceedings of a Specialty Conference Emission Inventory: Living in a Global Environment, Vol. 1*, New Orleans, LA, December 8-10, 1998; pp 193-203.
10. Holdren, M.W.; Wisbith, A.S.; Heggs, R.P.; Keigley, G.W.; Satola, J.R.; Williams, J.D.; Chuang, J.C. Final Report on Sampling and Analysis of Emissions Evolved during Extrusion of Polyamide Resin Mixtures Presented to The Society of the Plastics Industry, Washington, DC, June 1997.
11. U.S. Environmental Protection Agency. Compendium Method TO-13A: Determination of Polycyclic Aromatic Hydrocarbons (PAHs) in Ambient Air Using Gas Chromatography/Mass Spectrometry (GC/MS); EPA/625/R-96/010b; In *Compendium of Methods for the Determination of Toxic Organic Compounds in Ambient Air*; Center for Environmental Research Information: Cincinnati, OH, 1997.
12. U.S. Environmental Protection Agency. Compendium Method TO-14A: Determination of Volatile Organic Compounds (VOCs) in Ambient Air Using Specially Prepared Canisters with Subsequent Analysis by Gas Chromatography; EPA/625/R-96/010b; In *Compendium of Methods for the Determination of Toxic Organic Compounds in Ambient Air*; Center for Environmental Research Information: Cincinnati, OH, 1997.
13. Hughes, T.W.; Boland, R.F.; Rinaldi, G.M. *Source Assessment Plastic Processing State-of-the-Art*; Report PB 280 926; U.S. Department of Commerce, National Technical Information Service: Springfield, VA, March 1978.

### About the Authors

Joe Barnes is a product stewardship leader at Honeywell Engineered Applications & Solutions, P.O. Box 831, 4101 Bermuda Hundred Rd., Hopewell, VA 23860. John Bollmeier is a member of the DuPont Engineering Polymers Six Sigma Program, Chestnut Run Plaza 713/104, Wilmington, DE 19880. Jane Chen Chuang and Michael W. Holdren are senior research scientists at Battelle, 505 King Ave., Columbus, OH 43201. Anthony S. Wisbith is a principal research scientist at Battelle. Jennifer Hayward was assistant manager of environmental issues at SPI, Suite 600 K, 1801 K St., NW, Washington, DC 20006. George Kriek is associate research and development scientist at Bayer Corp., 100 Bayer Rd., Pittsburgh, PA 15205. Nelson Lazear is a manager for environmental issues at Bayer Corp. Diane Pietrzyk is manager of product stewardship at BASF Corp., 1609 Biddle Ave., Wyandotte, MI 48192. Verne Rhodes is president of Product Regulatory Services, 3731 Tiger Point Blvd., Gulf Breeze, FL 32561. Correspondence should be directed to SPI.

**TECHNICAL PAPER**

ISSN 1047-3289 *J. Air & Waste Manage. Assoc.* 47:1111-1118  
 Copyright 1997 Air & Waste Management Association

## Development of Emission Factors for Ethylene-Vinyl Acetate and Ethylene-Methyl Acrylate Copolymer Processing

**Anthony Barlow**

*Quantum Chemical Corporation, Cincinnati, Ohio*

**Pamela Moss**

*AT Plastics, Brampton, Ontario*

**Earl Parker**

*Chevron Chemical Company, Orange, Texas*

**Thomas Schroer**

*E.I. du Pont de Nemours & Co., Wilmington, Delaware*

**Mike Holdren**

*Battelle, Columbus, Ohio*

**Kenneth Adams**

*The Society of the Plastics Industry, Inc., Washington, D.C.*

### ABSTRACT

Emission factors for selected volatile organic compounds (VOCs) and particulate emissions were developed over a range of temperatures during extrusion of three mixtures of ethylene-vinyl acetate (EVA) copolymers and two mixtures of ethylene-methyl acrylate (EMA) copolymers. A mixture of low-density polyethylene (LDPE) resins was used as a control. EVAs with 9, 18, and 28% vinyl acetate (VA) were used. The EMA mixtures were both 20% methyl acrylate. A small commercial extruder was used. Polymer melt temperatures were run at 340 °F for LDPE and both 18 and 28% EVAs. The 9% EVA mixture was extruded at 435 °F melt temperature. The EMA mixtures were extruded at 350 and 565 °F melt temperatures.

An emission rate for each substance was calculated, measured, and reported as pounds released to the atmosphere per million pounds of polymer processed [ppm (wt/wt)]. Based on production volumes, these emission factors

can be used by processors to estimate emission quantities from EVA and EMA extrusion operations that are similar to the resins and the conditions used in this study.

### INTRODUCTION

Industry is faced with a new challenge. Pursuant to the Clean Air Act Amendments (CAAA) of 1990, which mandated the reduction of various pollutants released to the atmosphere, companies are being faced with the daunting task of establishing "emission inventories" for the chemicals used in their processes. The chemicals targeted are those that produce either volatile organic compounds (VOCs) or compounds that are on the list of 189 hazardous air pollutants (HAPs). Title V of the amended Clean Air Act established a permit program for emission sources to ensure an eventual reduction in emissions. When applying for a state operating permit, processing companies are first required to establish a baseline of their potential emissions.<sup>1</sup>

In response to the needs of the plastics industry, the Society of the Plastics Industry, Inc. (SPI) organized a study to determine the emission factors for ethylene-vinyl acetate (EVA) and ethylene-methyl acrylate (EMA) extrusion. Sponsored by four major resin producers, the study was performed at Battelle, an independent research laboratory. This work follows two previous SPI-Battelle studies on the emissions of polyethylene<sup>2</sup> and polypropylene.<sup>3</sup>

### IMPLICATIONS

This study provides quantitative emissions data collected during extrusion of ethylene-vinyl acetate (EVA) and ethylene-methyl acrylate (EMA) copolymers under specific operating conditions. These data can be used by processors as a point of reference to estimate emissions from similar EVA/EMA extrusion equipment based on production volumes.

A review of the literature shows that, while there are some qualitative and quantitative data available on polyethylene thermal emissions, there are fewer studies that mention EVA and EMA. The primary concern about previous polyethylene emissions data is that they were generated using static, small-scale,<sup>4</sup> or otherwise unspecified procedures.<sup>5,6</sup>

In the design stages of this and previous SPI-Battelle studies, considerable attention was given to whether the model used accurately reflected real processing conditions. The major contributing factors to the rate of emissions in an extrusion process were considered to be temperature, exposure to oxygen, and residence time. The goal was to reflect the actual on-line processing conditions rather than a static situation. In most extruders, the polymer melt continuously flows through the system, effectively limiting the residence time in any particular heated zone. If a static set-up were studied, the polymer may be exposed to the equivalent temperatures but for a longer period of time. This would effectively exaggerate the thermal exposure of the polymer. In a similar way, the concern over oxygen in the industrial extrusion process is minimized as the extruder screw design forces entrapped air back along the barrel during the initial compression and melting process. The air then exits the system through the hopper. Therefore, the hot polymer is exposed to air only when it is actually extruded through the die. In some of the static testing that has been reported, the hot polymer may have been exposed to air for extended periods of time.

The ideal would seem to be to measure the emissions directly from each individual process. In extrusion, for example, the type and quantity of emissions are known to be influenced by a number of operational parameters, including extruder size and type, extrusion temperature and rate, the air-exposed surface-to-volume ratio of the extrudate, the cooling rate of the extrudate, and the shear effect from the extruder screw. All of these would have to be specified and controlled.

**Table 1.** Average additive concentration (ppm) in polymer mixtures.

	SLIP	ANTI-BLOCK	ANTIOXIDANT
<b>EVA</b>			
18% VA	0	0	138
28% VA	0	0	263
9% VA	300	1500	145
<b>EMA</b>			
20% MA/3 MI	0	0	250
20% MA/6 MI	0	0	250
<b>LDPE</b>			
	156	300	340

The objective of the SPI-Battelle study was to take representative EVA/EMA resins from a number of suppliers and, using the same equipment used to study both polyethylene and polypropylene, provide baseline emission data. The test conditions used will provide reasonable reference data for processors involved in similar extrusion operations. In some cases the emission factors determined in this study may overestimate or underestimate emissions from a particular process. For example, a recent 2-year study<sup>7</sup> found, as would be expected, that a lower level of fume was generated by injection molding compared to extrusion-based processes in which the hot polymer is exposed to air. Therefore, professional judgment and conservative measures must be exercised when using the data for estimating emissions.

The samples used were mixtures of commercial copolymers from the sponsoring companies. The EVA mixtures, covering a range of 9 to 28% vinyl acetate, were composed of copolymers typically used in film forming, lamination, and hot-melt adhesive applications. The EMA mixtures containing 20% methyl acrylate were comprised of copolymers typically used in blown-film and extrusion coating applications. It should be noted that there are several variables related directly to the material being extruded that may influence the emissions. These variables include the age and type of resin, the additive package, and any additional materials added to the resin prior to extrusion. If a particular processor uses recycled materials, their thermal history is also an important factor. The test matrix used was designed to provide emissions data as a function of resin type and in some cases as a function of the operating temperature of the diehead assembly of the extruder. All of the EVA, LDPE, and EMA resins used were commercial grades. The average additive levels of the mixtures are shown in Table 1.

The equipment used was a small commercial extruder equipped with a 1.5-in. screw and fitted with an 8-strand die. The emissions were measured over a 30-minute period and were related to the weight of resin extruded. The emission factor for each substance measured was reported as pounds evolved to the atmosphere per million pounds of polymer processed [ppm(wt/wt)]. Processors using similar equipment can use these emission factors as reference points to assist in estimating emissions from their specific EVA-EMA application.

The 14 substances targeted for monitoring included particulate matter, total VOCs, light hydrocarbons (ethane, ethylene, and propylene), esters (vinyl acetate, and methyl acrylate), aldehydes (formaldehyde, acrolein, acetaldehyde, and propionaldehyde), ketones (acetone, and methylethyl ketone), and organic acids (formic, acetic, and acrylic acid). These are the analytes of interest, either because they are on the HAPs list, as stated earlier,

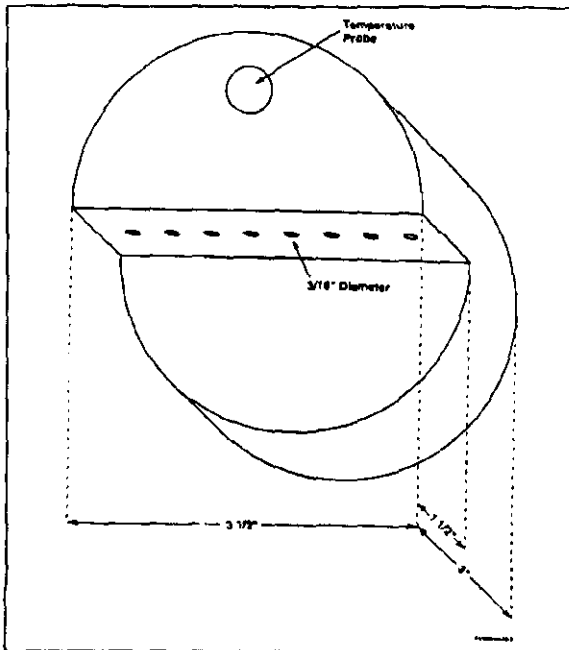

Figure 1. Extruder strand diehead used in EVA-EMA emissions testing program.

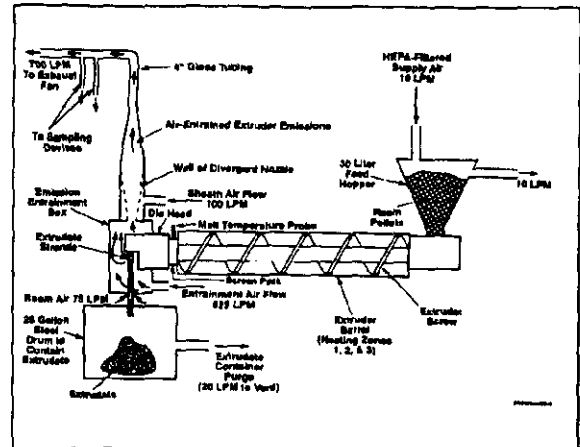

Figure 2. View of the extruder system and the various sampling locations.

or they are the expected thermal breakdown products of the polymers tested.

## EXPERIMENTAL PROCEDURES

### Experimental Process Conditions

An HPM Corporation 15-horsepower unvented extruder was used to process the EVA and EMA test sample mixtures at Battelle. The extruder was equipped with a 1.5-in. single screw (L/D ratio of 30:1) and fitted with an 8-strand die (Figures 1 and 2). Extruded resin strands were allowed to flow into a stainless steel drum located directly under the

Table 2. Resin throughput and key flow parameters during the EVA and EMA extrusion runs.

TEST RUN NO.	1A	1B	2	3	4	5	6
RESIN TYPE	Low-Density Polyethylene	Low-Density Polyethylene	EVA 18% VA	EVA 28% VA	EVA 9% VA	EMA 20% MA	EMA 20% MA
EXTRUDER CONDITIONS							
Melt Flow Rate	2	2	2	6	2	2	7
Average Diehead Melt Temperature, °F	340	340	340	340	435	350	565
Zone 3 Temperature, °F	292	301	301	301	415	300	547
Zone 2 Temperature, °F	296	297	297	297	365	300	449
Zone 1 Temperature, °F	275	274	275	274	275	275	275
Pressure, psig	1300	1500	1000	750	600	1750	<50
Resin Throughput [(lb/hr) (g/min)]	28.4/215	26.9/204	34.0/257	35.7/270	34.8/263	32.8/248	35.1/265
Rotor Speed, rpm	75	75	75	75	90	75	83
Run Duration, min	30	30	30	30	30	30	30
AIR FLOWS							
Total Manifold Flow, L/min	700	700	700	700	700	700	700
Flow Rate Into Sheath Area, L/min	100	100	100	100	100	100	100
Flow Rate Into Entrainment Area, L/min	525	525	525	525	525	525	525
Flow Rate Through Hopper, L/min		10	10	10	10	10	10 10
Flow Through Tubes for Carbonyls, L/min	0.5	0.5	0.5	0.5	0.5	0.5	0.5
Flow Through Tubes for Organic Acids, L/min	5	5	5	5	5	5	5
Flow Into Canisters, L/min	0.16	0.16	0.16	0.16	0.16	0.16	0.16
Flow Through 402 THC Analyzer, L/min	1	1	1	1	1	1	1
Flow Through Filter Holder, L/min	15	15	15	15	15	15	15



**Table 3.** Order of EVA and EMA emissions test runs.

Run No. Sequence	Resin Type	% MA or VA	Melt Index (°F)	Melt Temp	Companies Contributing to Resin Mixture
1A	LDPE	0	2	340	Quantum NA 345 DuPont 20 AT 220 PE 5565 (Chevron)
1B	Use for spiking run				
2	EVA	18	2	340	Quantum UE631 ELVAX 3170 AT 1815
3	EVA	28	6	340	Quantum UE634 ELVAX 3175 AT 2810 M
4	EVA	9	2	435	Quantum UE637 ELVAX 3128 AT 1070 PE 5280 (Chevron)
Use LDPE mixture while cooling to 350 °F					
5	EMA	20	2	350	Quantum EMTR 003 SP 2205 (Chevron)
6	EMA	20	7	565	Quantum EMTR 010 SP 2207 (Chevron)

LDPE resin mixture was used to clean extruder during cool down. Extruder was purged of EMA before final shutdown to avoid corrosion.

die-head (Figure 2). Processing conditions, shown in Table 2, were selected to be representative of several commercial processing applications. The order of the EVA-EMA Emissions test runs is listed in Table 3.

**Capture and Collection of Emissions**

Emissions released at the diehead were collected separately for 30 minutes during the extrusion runs. Emissions from the hopper were excluded from analysis because previous emission studies showed their contribution to be insignificant (less

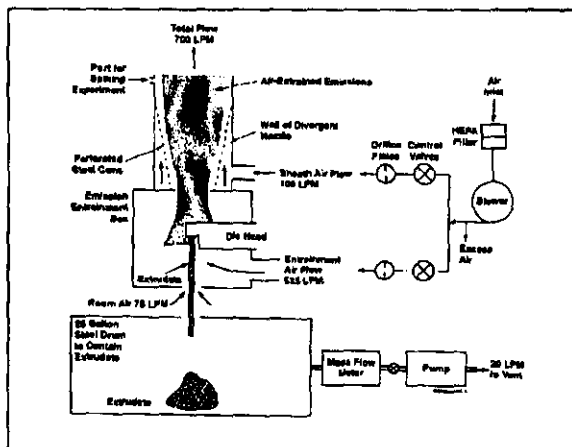

**Figure 3.** View of emission entrainment area.

than 2% of the total).<sup>2</sup> Table 4 shows the sampling strategy and the overall analytical scheme employed for the EVA and EMA test runs. Details of the analytical procedures are provided in the paper "Development of Emission Factors for Polyethylene Processing."<sup>2</sup>

**Diehead Emissions**

Emissions released at the diehead during extrusion were captured at the point of release in a continuous flow of clean air. A portion of this airflow was subsequently sampled downstream, as described below. The emissions were initially captured in a stainless-steel enclosure surrounding the diehead (Figure 3). The air stream was immediately drawn through a divergent nozzle entrainment cone, which provided a sheath of clean air between the diehead emission flow and the walls of the carrier duct. This minimized interaction of the hot exhaust with the cooler duct walls.

The total airflow employed for capturing diehead emissions was set at 700 L/min. This was composed of the diehead entrainment flow at 525 L/min, the sheath flow at 100 L/min, and 75 L/min of residual airflow, which was made up from room air drawn into the open bottom of the stainless-steel diehead enclosure.

This residual airflow was used to facilitate effective capture of emissions from the polymer. These flows are depicted in Figures 2 and 3.

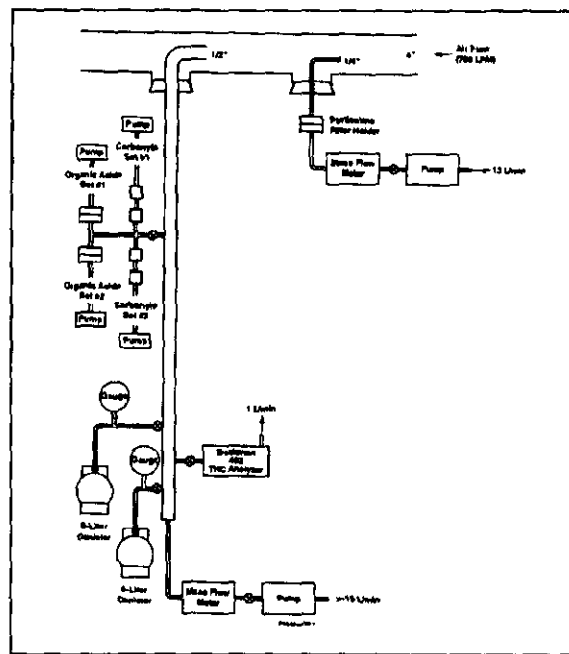

**Figure 4.** Sampling manifolds for emissions generated in diehead.

**Table 4.** Sample collection scheme for EVA and EMA test runs.

SUBSTANCES MONITORED	Organic Acids	Aldehydes/ Ketones	Particulate	VOCs			
				HHC	LHC		
<b>COLLECTION MEDIA</b>	KOH Impregnated Filter	DNPH Tube	Glass Fiber Filter	SUMMA Canister			
<b>ANALYTICAL METHOD</b>	Desorption with Dilute H <sub>2</sub> O <sub>4</sub> and Analysis by Ion Exclusion Chromatography/UV	Desorption with Acetonitrile and Analysis by HPLC	Gravimetric	Modified T0-14			
				HP-1 Fused Silica Capillary Column GC/MS	Al <sub>2</sub> O <sub>3</sub> /Na <sub>2</sub> SO <sub>4</sub> Capillary Column GC/FID	GC/FID	
<b>SAMPLING LOCATION</b>	Manifold						
Melt Temp (°F)	Run No.	Number of Samples Analyzed					
340	1A	2	2	1	1	2	1
340	1B	2	2	1	1	2	1
340	2	2	2	1	1	2	1
340	3	2	2	1	1	2	1
435	4	2	2	1	1	2	1
350	5	2	2	1	1	2	1
565	7	2	2	1	1	2	1

Note: No processing aids were used.

Diehead emissions were transported by the 700-L/min airflow to a sampling point 10 ft. downstream of the diehead using 4-inch-diameter glass tubing. The location for this sampling point (Figure 2) was based on previous studies performed at Battelle that involved design, engineering, implementation, and proof-of-principle stages for the pilot plant system.<sup>2</sup>

Two separate sampling manifolds were used at the sampling location: one for collecting gases and vapors and the

other for collecting particulates (Figure 4). For gases and vapors, a 10-L/min substream was diverted from the main emission entrainment stream using a 0.5-in. stainless steel tube (0.425-in. i.d.) wrapped with heating tape and maintained at 50 °C. VOCs and oxygenates were sampled from this manifold. Similarly, particulates were sampled from a separate 15-L/min substream using a 0.25-in. stainless unheated steel probe (0.1375-in. i.d.).

This study did not include any measurements of emissions from the drum collection area, as all commercial extrusion processes quench the molten resin shortly after it exits the die. Emissions from the extrudate in the collection drum were prevented from entering the diehead entrainment area by drawing air from the drum at 20 L/min and venting to the exhaust duct.

#### VALIDATION OF THE ANALYTICAL METHOD

The purpose of the manifold spiking experiments was to determine the collection and recovery efficiencies of the canister, acid, and carbonyl collection methods. During the first spiking experiment, all three collection methods were evaluated. Results are reported in detail elsewhere.<sup>2</sup> During the second

**Table 5.** Results from spiking experiments.

ANALYTE	METHOD	SPIKE LEVEL µg/L	RECOVERY µg/L		AVERAGE PERCENT RECOVERED*
			Set 1	Set 2	
FIRST EXPERIMENT <sup>a</sup>					
Formic Acid	KOH filters	0.71	0.987	0.733	122±18
Acetic Acid	KOH filters	0.77	1.023	0.640	121±12
Acrylic Acid	KOH filters	0.59	0.687	0.567	107±11
Formaldehyde	DNPH Cartridge	1.63	2.20	2.03	130±5
Benzene-d <sub>6</sub>	Canister	0.092	0.088	0.086	95±2
SECOND EXPERIMENT <sup>b</sup>					
Benzene-d <sub>6</sub>	Canister	0.24	0.27	0.25	108±4
Benzene	Canister	0.22	0.22	0.22	100
Methyl Acrylate-d <sub>3</sub>	Canister	0.25	0.26	0.24	100±4
Methyl Acrylate	Canister	0.25	0.25	0.23	95±4
Vinyl Acetate	Canister	0.24	0.28	0.25	110±6

\*Relative error is the relative percent difference: the absolute difference in the two samples multiplied by 100 and then divided by their average.

<sup>a</sup>Reference 2; <sup>b</sup>Reference 3

**Table 6.** Summary of EVA and EMA thermal process emissions for generic resin grades ( $\mu\text{g/g}$ ).

TEST RUN NO.	1A	1B	2	3	4	5	6
Resin Type	Low-Density Polyethylene	Low-Density Polyethylene	EVA 18% VA	EVA 28% VA	EVA 9% VA	EMA 20% MA 3 MI	EMA 20% MA 6 MI
Die Melt Temperature ( $^{\circ}\text{F}$ )	340	340	340	340	435	350	565
Particulate Matter	<1	1.5	<1	<1	<1	4.1	61.5
VOLATILE ORGANIC COMPOUNDS							
Beckman 402-THC*	106.7	106.9	128.2	123.4	99.7	45.7	117.2
Heavy Hydrocarbons (HHC) B5.0		83.0	108.3	109.9	86.4	44.2	90.0
LIGHT HYDROCARBONS (LHC)							
Ethane	0.02	0.02	0.01	0.01	0.03	0.02	0.49
Ethylene	0.01	0.01	0.01	0.01	0.02	0.02	0.36
Propylene	0.01	0.01	0.01	0.01	0.01	0.01	0.14
ESTERS							
Vinyl Acetate	<0.01	<0.01	<0.01	6.22	<0.01	<0.01	<0.01
Methyl Acrylate	<0.01	<0.01	<0.01	<0.01	<0.01	<0.01	<0.01
ALDEHYDES							
Formaldehyde†	0.42	0.28	0.08	0.08	0.13	0.09	1.07
Acrolein†	<0.01	<0.01	<0.01	<0.01	<0.01	<0.01	0.10
Acetaldehyde†	0.09	0.07	0.04	0.03	0.10	0.03	0.77
Propionaldehyde†	0.02	0.01	0.01	0.01	0.02	<0.01	0.31
Butyraldehyde	0.02	0.02	0.01	0.01	0.04	0.02	0.49
Benzaldehyde	0.02	0.02	0.03	0.05	0.05	0.03	0.23
KETONES							
Acetone	0.15	0.13	0.10	0.10	0.13	0.10	0.34
Methyl Ethyl Ketone†	<0.01	<0.01	<0.01	<0.01	<0.01	<0.01	<0.01
ORGANIC ACIDS							
Formic Acid	0.27	0.22	3.85	3.11	6.05	4.40	4.66
Acetic Acid	0.44	0.44	7.40	2.89	5.32	2.06	3.23
Acrylic Acid†	<0.02	<0.02	<0.02	<0.02	<0.02	<0.02	<0.02

Note: No processing aids were used.

\* THC = Total hydrocarbons minus methane.

† Hazardous air pollutants (HAPs).

spiking experiment, collection and recovery efficiencies were determined only for the canister sampling method. The results from the two spiking experiments are summarized in Table 5. The analytes measured by the spiking experiments are listed in Column 1. Column 3 shows the calculated concentrations of the spiked compounds in the air stream of the manifold. The concentrations found from duplicate sampling and analyses, and corrected for background levels, are shown in the next two columns. Finally, the average percent recovered is given in the last column.

The results from the first experiment are summarized as follows: all three collection methods showed very good

recoveries of the manifold spiked compounds; the three organic acids were spiked at a nominal air concentration of about 0.6 to 0.8  $\mu\text{g/L}$ ; recoveries using the KOH-coated filters ranged from 107 to 122%; formaldehyde (1.63  $\mu\text{L}$ ) served as the surrogate for the aldehyde-ketone species and the DNPH cartridge method showed a recovery of 130%; deuterated benzene (0.092  $\mu\text{g/L}$ ) served as the representative compound for the canister collection method; and the amount recovered was 95%.

During the second experiment, additional recovery data points were obtained for the canister method using an expanded list of compounds. The additional compounds

**Table 7.** Coefficient for equations predicting EMA emission levels,  $Y = MT + C$ , where T is extrusion temperature ( $^{\circ}\text{F}$ ) and Y is emission quantity in lbs per million lbs of resin.

EMA (20% Copolymer)	Temperature Range	M Slope	C (y Intercept)
VOC (402 method)	350 - 565 $^{\circ}\text{F}$	0.33	-70.7
Particulates	350 - 565 $^{\circ}\text{F}$	0.27	-89.3
Formaldehyde	350 - 565 $^{\circ}\text{F}$	0.0046	-1.15
Acetaldehyde	350 - 565 $^{\circ}\text{F}$	0.0034	-1.17
Formic Acid	350 - 565 $^{\circ}\text{F}$	0.0012	3.98
Acetic Acid	350 - 565 $^{\circ}\text{F}$	0.0054	0.16

Other hydrocarbons and acids were detected, but were below the 0.75 ppm cut-off point.

included deuterated benzene for comparison with the first experiment, as well as benzene, methyl acrylate, deuterated methyl acrylate, and vinyl acetate. The expected spike level of these five species was nominally 0.24  $\mu\text{L}$ . As the results indicate, excellent recoveries were obtained for all compounds. Mass ions from the mass spectrometric detector that were specific for each compound were used in calculating recovery efficiencies because the five species were not well resolved with the analytical column (e.g., the two methyl acrylates were seen as one peak when monitoring the flame ionization detector).

## EMISSION FACTOR RESULTS

### Ethylene Vinyl Acetate Copolymers

The emission results are presented in Table 6. Overall, VOCs and particulates for all three EVA test resins had much higher emission rates than the oxygenates. VOC emissions ranged from 100 to 130 ppm (wt/wt), while particulates were less than 1 ppm. The higher test temperature produced higher levels of aldehydes, but lower overall VOCs. However, this result is confounded because different EVA resins were used.

As discussed in the experimental section, two different methods were used to measure VOC emissions. One was the Beckman 402 Hydrocarbon Analyzer which continually analyzed the air emission stream throughout the run and provided a direct reading of all VOC substances responding to the flame ionization detector. The other method used an evacuated canister for sample collection and gas chromatography for analysis. With this method, total VOCs were determined by summing the Heavy Hydrocarbon (HHC) and Light Hydrocarbon (LHC) results.

As can be seen in Table 6, the Beckman 402 results are consistently higher than the HHC and LHC results. There are a number of possible explanations for these discrepancies, as the techniques are inherently different, but that discussion is beyond the scope of this paper. However, as a conservative measure, it is recommended that the higher result be used when estimating emission quantities.

One advantage of the canister method is that it can provide emission data on total VOCs as well as individual compounds. Based on visual observation of the

VOC chromatograms, the VOC measurements were due to the additive response of many individual compounds. The majority of individual VOCs were well below 1 ppm (wt/wt). The exceptions were the organic acids, which were in the range of 6 to 12 ppm total. Variations in the amounts of organic acids evolved did not follow either the die-melt temperature or the percent bound vinyl acetate. This may have been simply a reflection of the variability of the method, or the effect of different samples being used at different temperatures. Organic acid emissions were, however, significantly higher than those observed in an earlier study on LDPE resins.<sup>2</sup>

Vinyl acetate was detected in only one of the test runs, that of the high vinyl acetate copolymer in Run #3. It is thought that this may have been an artifact of the test apparatus in which fewer VOCs may have adhered to the canister wall during sample storage and were not completely released during sample analysis.

### Ethylene-Methyl Acrylate Copolymers

The emission factor results for the EMA copolymers are presented in Table 6. Extrusions were performed at 350 and 565  $^{\circ}\text{F}$ , corresponding to blown film and extrusion coating temperatures, respectively. Overall, the VOCs for the test resins had higher emission rates than the oxygenates. VOC emissions ranged from 45 to 117 ppm (wt/wt) and the particulates from 4 to 61 ppm (wt/wt). As expected, the higher test temperatures generally produced the higher emission factors. Even at the highest test temperature, the majority of individual VOCs were below 1 ppm (wt/wt) and no single VOC compound exceeded 5 ppm (wt/wt). Those that exceeded 1 ppm were aliphatic hydrocarbons in the  $\text{C}_{10}$  to  $\text{C}_{16}$  range.

Oxygenated VOCs were present in the emissions at both temperatures, but generally at values <1 ppm (wt/wt). The exceptions were formic acid, and acetic acid detected at levels of < 5 ppm at both extrusion temperatures, and formaldehyde, detected at a level of approximately 1 ppm at 565  $^{\circ}\text{F}$  extrusion temperature. From the structure of the ethylene-methyl acrylate copolymer shown below, it was thought that methanol would be generated during extrusion at the highest temperature.

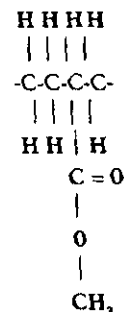

However, specific evaluation of the GC-MS runs for methanol showed this compound to be absent in runs made at both extrusion temperatures. The oxygenated compounds on the HAPs list are designated as such in Table 6.

#### Predicting Emissions within Experimental Temperature Range

The data in Table 6 were reduced to the following equation for EMA that predicts the level of emissions at a specific extrusion temperature:

$$Y = (M \times T) + C \quad (1)$$

where Y = emissions in pounds per million pounds of processed resin, and T = melt temperature in °F. M and C constants are shown in Table 7 for each analyte.

Inserting the melt temperature (°F) into the equation will provide an estimate of the number of pounds of emissions per one million pounds of processed polymer. This equation is only valid within the temperature ranges and conditions used in this study and is not recommended for predicting emissions for temperatures outside this range. A similar equation was not derived for EVA because of the limitations of test temperatures.

#### CONCLUSION

##### Significance of Emission Factors from SPI Study

This study provides published emission rate data collected during extrusion of EVA and EMA under specific operating conditions.

The significance of this data becomes apparent when placed into context of the 1990 Clean Air Amendment's definition of a "major" source for VOC emissions. Categorization of an emission source as a "major" source subjects it to more stringent permitting requirements. The definition of a "major" source varies with the severity of the ozone nonattainment situation of the area where the source is located. The current VOC emission limits are 10 tons per year for a source in the severe classification, and 50 tons per year for a source in the serious classification. Currently, the only extreme nonattainment area in the United States is the Los Angeles, California area.

The utility of this data can be illustrated in the following example. Based on the emissions data and equations developed in this effort, a processor with equipment and conditions similar to those in this study can extrude up to 156 million pounds of EVA or 171 million pounds of EMA, and using the maximum emissions discovered in this study without exceeding the 10-ton-per-year limit for an extreme ozone nonattainment area. However, before using the data in this paper to estimate emissions, one must consider a number of other parameters, such as increased additive levels, which may impact the type and quantity of emissions as discussed in the Introduction.

These results cannot be used for industrial hygiene purposes.

#### REFERENCES

1. Sherman, L. M. "Clean-air rules challenge processors," *Plastics Technology* 1995, 41: 2, 83-86.
2. Barlow, A.; Contos, D.; Holdren, M.; Garrison, P.; Harris, L.; Janke, B. "Development of emission factors for polyethylene processing," *J. Air & Waste Manage. Assoc.* 1996, 46, 569-580.
3. Battelle Final Report to the Society of the Plastics Industry, "Sampling and analysis of emissions evolved during thermal processing of polypropylene resin composites," March 1995.
4. Hoff, A.; Jacobsson, S. "Thermo-oxidative degradation of low density polyethylene close to industrial processing conditions," *J. Applied Polymer Science* 1981, 26, 3409-3423.
5. Hughes, T. W.; Boland, R. F.; Rinaldi, G. M. *Source Assessment: Plastics Processing, State of the Art*, EPA-600/2-78-004C, pp. 27-28, 1978.
6. *Air Facility Subsystem Source Classification Codes and Emission Factor Listing for Criteria Air Pollutants*, U.S. Environmental Protection Agency, 1990, EPA 450/4-90-003.
7. Forrest, M. J.; Jolly, A. M.; Holding, S. R.; Richards, S. J. "Emissions from processing thermoplastics," *Annals of Occupational Hygiene* 1995, 39: 1, 35-53.

#### About the Authors

Anthony Barlow, Ph.D., is a retired product steward for Quantum Chemical Company. Pamela Moss is the laboratory and support services manager for AT Plastics, Inc. Earl Parker is retired product compliance manager for Chevron Chemical Company. Thomas Schroer is regulatory affairs consultant for E.I. du Pont de Nemours & Co. Mike Holdren is a senior research scientist at Battelle Memorial Institute. Kenneth Adams (corresponding author) is the assistant technical director with The Society of the Plastics Industry, Inc., 1801 K Street NW, Suite 600K, Washington, D.C. 20006-1301.

# Sampling and Analysis of Volatile Organic Compounds Evolved During Thermal Processing of Acrylonitrile Butadiene Styrene Composite Resins

Exhibit 8

D.A. Contos, M.W. Holdren, and D.L. Smith  
*Battelle Memorial Institute, Columbus, Ohio*

R.C. Brooke  
*GE Plastics, Parkersburg, West Virginia*

V.L. Rhodes  
*Monsanto Chemical Company, St. Louis, Missouri*

M.L. Rainey  
*Dow Chemical Company, Midland, Michigan*

## ABSTRACT

The evaluation of emissions of volatile organic compounds (VOCs) during processing of resins is of interest to resin manufacturers and resin processors. An accurate estimate of the VOCs emitted from resin processing has been difficult due to the wide variation in processing facilities. This study was designed to estimate the emissions in terms of mass of emitted VOC per mass of resin processed.

A collection and analysis method was developed and validated for the determination of VOCs present in the emissions of thermally processed acrylonitrile butadiene styrene (ABS) resins. Four composite resins were blended from automotive, general molding, pipe, and refrigeration grade ABS resins obtained from the manufacturers. Emission samples were collected in evacuated 6-L Summa canisters and then analyzed using gas chromatography/flame ionization detection/mass selective detection (GC/FID/MSD). Levels were determined for nine target analytes detected in canister samples, and for total VOCs detected by an inline GC/FID. The emissions evolved from the extrusion of

each composite resin were expressed in terms of mass of VOCs per mass of processed resin. Styrene was the principal volatile emission from all the composite resins. VOCs analyzed from the pipe resin sample contained the highest level of styrene at 402  $\mu\text{g/g}$ . An additional collection and detection method was used to determine the presence of aerosols in the emissions. This method involved collecting particulates on glass fiber filters, extracting them with solvents, and analyzing them using gas chromatography/mass spectrometry (GC/MS). No significant levels of any of the target analytes were detected on the filters.

## INTRODUCTION

Emissions of volatile organic compounds (VOCs) during processing of resins is of concern to resin manufacturers and processors. Emission information for individual VOCs will help the industry comply with the 1990 Clean Air Act Amendments. However, efforts to make quantitative estimates of emissions from resin processing must take into account the wide variation in processing facilities. Exhaust concentrations during fabrication may not be accurately generalized to other facilities or even to other processing conditions at the same facility. This study was undertaken to quantify emissions of VOCs and to express those emission values in terms of mass of emitted VOCs per mass of processed resin. In this way, the results can be used to obtain a more realistic value for emissions from a resin processing facility.

In this study, gaseous emissions generated during the extrusion of acrylonitrile butadiene styrene (ABS) resins were collected with stainless steel canisters treated by the Summa passivating process. The canister samples were analyzed by a gas chromatography (GC) system equipped with a sample pre-concentration device, and using parallel flame ionization

## IMPLICATIONS

There is a lack of data available concerning individual volatile organic compounds (VOCs) emitted during the processing of commercial acrylonitrile butadiene styrene (ABS) resins. In this study, a collection and analysis method has been developed and validated using deuterated species spiked into the exhaust stream of thermally processed ABS resins. The study design allows for the calculation of process emissions in terms of mass of emitted individual VOC per mass of resin processed. We believe that the method will serve as a valuable analytical tool for industry and the research community in better assessing air toxics and VOC emissions from chemical processes in general.

detection (FID) and mass selective detection (MSD). A similar method was successfully used in past studies characterizing aircraft engine exhaust emissions for the U.S. Air Force.<sup>1,2</sup> A Beckman 402 total VOC analyzer, an in-line continuous monitor with a flame ionization detector and heated probe, was also used to measure total VOCs and to compare with the results found by summing the individual species obtained with the GC system.

Dow Chemical Company, General Electric Company, and Monsanto Chemical Company provided one resin from each of four categories of resins—automotive, general molding, pipe, and refrigeration ABS resin. Composite resin samples were prepared by combining equal portions of resin from the same resin category from each company. The resins were mixed thoroughly to provide four composite samples.

A resin extruder and exhaust delivery system were used to generate and capture emissions produced during the extrusion of the composite resins. This facility had been designed to perform safety evaluations of emissions produced during plastic processing under controlled laboratory conditions modelling industrial practice.<sup>3</sup>

The study design consisted of two phases: 1) development and validation of a gaseous emission sample collection and analysis method, and 2) collection and analysis of VOCs emitted from the extrusion of each composite resin.

## EXPERIMENTAL METHODS

### Extrusion Facility and Collection Methods

**Resin Extrusion Facility.** The resin extrusion facility at Battelle was used to generate and capture VOCs produced during the extrusion of ABS resins. The resin extrusion equipment was isolated from the rest of the facility in a room equipped with a separate air handling system housing two extrusion lines in separate isolation enclosures maintained at a negative pressure relative to the rest of the facility. The isolation enclosures were constructed of prefabricated insulated panels which ensured that the noise levels in the generation area did not exceed 80 dB. The design of the facility allowed the system operator to maintain conditions within specified limits and to collect, analyze, and report the conditions in real time during each test.

The emissions that evolved during thermal processing of resins were captured in a stainless-steel enclosure

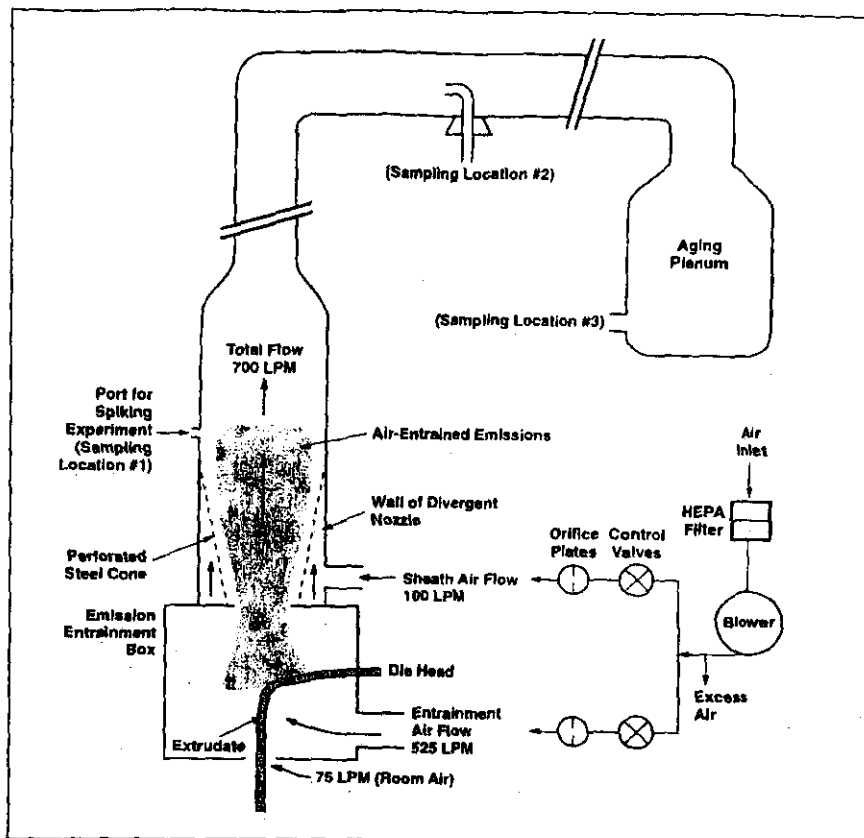

Figure 1. Delivery system and sampling locations.

surrounding the die head of a 1.5-in, 15-hp plastic extruder (HPM Corporation). Fitted with an eight strand die, the extruder is capable of a production rate over 60 lbs/hr throughput and 800°F (maximum) barrel temperatures for the three heat zones. The thermal processing involved the extrusion of each composite under conditions considered suitable for the ABS resins.

The emissions were entrained with pre-conditioned air (high efficiency particulate aerosol-filtered) using a Battelle-developed divergent nozzle entrainment cone with flow through a three-inch diameter glass sampling manifold (Figure 1). The cone provided a sheath of clean air between the exhaust emissions and the walls of the carrier duct, minimizing interaction of the effluent with the duct walls.

The delivery system was designed with multiple sampling ports at various distances from the extruder to determine the component's concentration at chosen locations. Figure 1 is a schematic diagram of the sampling port locations. Sampling port two was used for sampling in this program based on results from previous industrial studies which involved design, engineering, implementation, and testing of the plastic extrusion and delivery system laboratory.

**Composite Sample Preparation Process.** The composite resins were prepared using a Patterson-Kelly twin shell, 3 ft<sup>3</sup> blender to mix 50 lbs of each resin type from each company to form 150 lbs of each composite. A composite of the

extruder purging resin, styrene-acrylonitrile (SAN) resin, was also prepared from equal parts of Tyril® 880 SAN from Dow, and Lustran® 31-2060 SAN from Monsanto. Table 1 shows the four composite categories, the resins used from each company, and the extruder conditions for the composite sample collection in Phase 2.

**Sample Loading Process.** Resin was hand-poured into a dryer hopper mounted on the extruder. During the extrusion process the plastic extrudate passed through the exhaust entrainment section into a 55-gal steel drum where it cooled and was weighed. The resin processing rate was determined by weighing the amount of resin extruded during a measured time interval.

**Canister Preparation Method.** The canisters used to collect emission samples were cleaned and evaluated following the Compendium Method TO-14<sup>4</sup> procedure recommended by the Quality Assurance (QA) Division of the U.S. EPA. The 6-L canisters were cleaned by placing them in a 50°C oven, evacuating them to a pressure less than 125 mm of Hg, and filling each canister five times to at least 4 psig, using humidified ultra-high purity air as the flush gas. A final canister vacuum of 0.10 mm of Hg or less was achieved by using a mechanical pump. One out of every eight canisters was filled with humidified ultra-high purity air and its contents analyzed as a quality control (QC) measure.

**Table 1.** Phase 2 extruder operating conditions.

Resin:	Auto Comp	General Molding Comp	Pipe Comp	Refrig Comp	General Molding Comp Duplicate
Run Duration (min):	32	32	35	24	23
Total Flow (L/min):	700	700	700	700	700
Carrier Flow (L/min):	525	525	525	525	525
Sheath Flow (L/min):	100	100	100	100	100
Screw Speed (rpm):	90	90	90	90	90
Die Pressure (psi):	1500	1500	2000	2000	2000
Output (lbs/hr):	48.4	51.7	45.0	50.6	51.4
Temperatures (°F):					
Zone 1	340	351	355	353	350
Zone 2	398	400	403	402	400
Zone 3	448	449	452	452	449
Die	452	450	452	450	450
Melt	455	443	445	463	440

**NOTES**

Comp = Composite resin  
 Automotive composite resin (auto): Magnum® 342EZ, Cyclolac® GDT 6300, Lustran® SF Elite-1000.  
 General molding (GM) composite: Magnum® 9010, Cyclolac® GPM 5600, Lustran® Ultra MCX.  
 Refrigeration composite (Refrig): Magnum® 9043 white, Cyclolac® N24 white, Lustran® 723 white.  
 Pipe composite (Pipe): Magnum® FG 960 black, Cyclolac® LDG, Lustran® 756. Magnum® Trademark of the Dow Chemical Company.  
 Cyclolac® Trademark of General Electric Company.  
 Lustran® Trademark of Monsanto Chemical Company

**Canister and Filter Sample Collection Method.** A heated manifold constructed from 1/2 in stainless steel tubing was used for the collection of filter and canister samples. The manifold (see Figure 2) consisted of a 90 degree elbow which protruded into the main exhaust glass manifold at sampling position 2. The manifold was attached using a 4-in stopper. The stopper was sealed to the 3-in diameter glass manifold using glass fiber tape. Directly below the stopper was a 3/8-in port with a stainless steel filter holder. During the validation phase, this sampling port was used to collect the 60-L filter sample as well as to obtain direct canister samples to determine if manifold losses were occurring. Four 1/4-in ports and one 3/8-in port were positioned at the lower end of the manifold. A filter holder was connected to the 3/8-in port with a flexible 1/4-in heated line attached to the exit end. Another flexible 1/4-in heated line was attached directly to one of the 1/4-in ports. These two heated flexible lines were used for canister sample collections. The Beckman 402 VOC analyzer's heated line was attached to one of the other 1/4-in ports. One of the remaining two ports was sealed and the other was attached to a mass flow meter and pump which maintained a flow of 10 L/min through the sampling manifold. The entire manifold, including filter holders and flexible lines used for canister sampling, was heated using heating tapes and rheostats. All temperature zones were monitored by thermocouples and maintained at a constant temperature of 120°C ± 20°C.

Each canister sample was collected by attaching the canister to its respective port and slowly opening the manual valve to allow the differential pressure between the exit exhaust and the evacuated canister to cause flow into the canister. Once the canister had reached ambient pressure the valve was closed and the canister was removed.

Filter samples were collected by placing a pre-weighed 25 mm diameter glass fiber filter in-line preceding one of the 6-L canisters as shown in Figure 2. A 6-L volume was passed through the filter during the 1-min collection period in which the canister valve was opened. In addition, a glass fiber filter sample was collected at the 3/8-in port directly below the manifold rubber stopper at a flow rate of 10 L/min for 6 min, resulting in a sampled volume of 60 liters.

**Analysis Methods**

**In-Line Volatile Organic Compound Analyzer.** A Beckman 402 in-line continuous monitoring FID system was used to measure the VOC content of the exhaust as shown in Figure 2. This instrument was in place during the sampling period at sampling location 2 (shown in Figure 1). The total VOC determination was made by assuming an equal response (per carbon) for each emitted species detected by the in-line FID system. By using the reference calibration standard, benzene, a total concentration value in the exhaust stream was calculated in units of parts per million carbon (ppmC) or



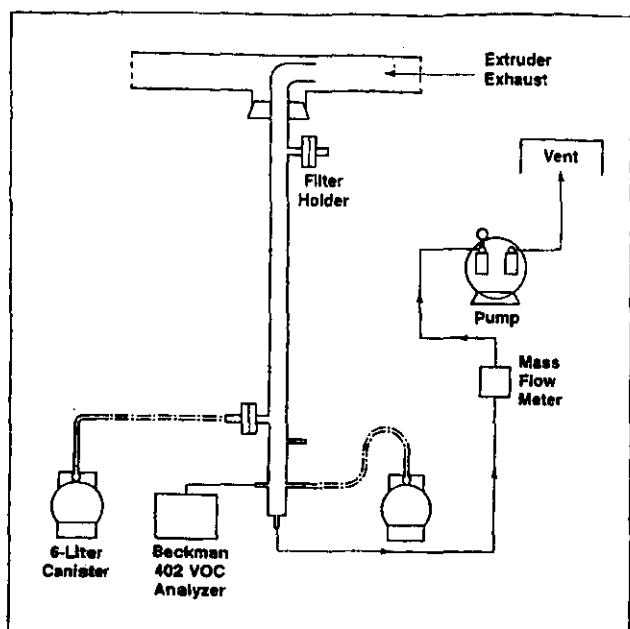

Figure 2. Sampling manifold.

$\mu\text{g}/\text{m}^3$ . By accurately measuring the exhaust flow, the emission values were calculated in units of  $\mu\text{g}/\text{sec}$ . The continuous in-line monitor provided a record of the variability of the VOC in the exhaust. This method also served as a comparison to the canister VOC measurements made by the GC/FID/MSD system.

**GC/FID/MSD Analysis Method.** The canister samples were analyzed for VOCs using an automated gas chromatographic system utilizing a Hewlett-Packard Model 5880 GC and parallel flame ionization and mass selective detectors. A modified Nutech Model 320 controller regulated the temperature of the Supelco two-phase preconcentration trap, which contained a bed of Carboxpack B and Carbosieve S-III adsorbent. A six-port valve was used to facilitate sample collection and injection. For this study, each canister was heated to  $120^\circ\text{C}$  just before analysis. A 40 cc sample from each canister was then transferred to the trap, which was initially held at a temperature of  $25^\circ\text{C}$ , followed by desorption at  $220^\circ\text{C}$ . Analytes were chromatographically resolved on a Hewlett-Packard HP-1 fused silica capillary column (50 m x 0.32 mm i.d.,  $1\mu\text{m}$  film thickness). Optimal analytical results were achieved by temperature programming the GC oven from  $-50^\circ\text{C}$  to  $200^\circ\text{C}$  at  $8^\circ\text{C}/\text{min}$ . The column exit flow was split to direct one-third of the flow to the MSD and the remaining flow through the FID. The VOCs were identified using the MSD and were quantified using the FID.

The MSD was operated in the full scan positive ion mode so that all the masses between 35 and 250 daltons were scanned and recorded. This mode is ideal for analyzing unknown compounds, because it provides a complete mass spectrum for each GC peak. The mass spectrometer's electron multiplier was set at 2200 V.

Major components (those with approximate signal-to-noise ratio greater than 10:1) were identified both by manual interpretation and by matching the mass spectra from the samples to the National Institute of Standards and Technology (NIST) mass spectral library, using the MSD data system library search function. The target analytes detected in the canister samples were the following: 1) acrylonitrile, 2) 1,3-butadiene, 3) 4-vinyl-1-cyclohexene, 4) ethylbenzene, 5) styrene, 6) isopropylbenzene, 7) propylbenzene, 8) methyl styrene, 9) acetophenone and 10) 2-phenyl-1-propanol.

### Phase 1: Development and Validation of a Sample Collection and Analysis Method

Phase 1 involved the design, setup, and validation of the canister collection and analysis method for the determination of VOCs in exhaust generated by the extrusion of ABS resins. Compounds used in these experiments were the ten target analytes listed above, as well as benzene and three deuterated species: ethylbenzene- $\text{d}_{10}$ , styrene- $\text{d}_8$ , and acetophenone- $\text{d}_8$ . Initial experiments focused on determining the storage and recovery of these target species, which were spiked into the canisters. Subsequent test runs were performed with the extrusion of Dow's Magnum® 342EZ ABS automotive resin to determine: 1) if gaseous species were lost in the sampling manifold through aerosol formation, and 2) if gaseous species released in the extrusion zone were efficiently recovered at the sampling location.

**Phase 1: Canister Recovery Test.** A canister-spiking experiment was performed to confirm the elution and recovery of the target analytes from 6-L canisters using the GC/FID/MSD system. A 1/1000 dilution of the target analytes was prepared by injecting 10  $\mu\text{L}$  of each liquid into a 10 mL volumetric flask half filled with methanol. The flask was then filled to the mark with methanol. A 6-L canister was cleaned and evacuated. The canister was spiked with 5  $\mu\text{L}$  of the diluted mixture and then filled to 15 psig with humidified zero air. The canister was analyzed using the GC/FID/MSD system to identify and confirm each analyte. Compound recovery was determined by comparing the calculated canister concentrations with the experimental values based upon the analysis of a diluted mixture from a calibration cylinder that also contained the target compounds.

**Phase 1: Gaseous Species and Aerosol Formation.** The extruder was cleaned of residual resin by purging with Dow's Tyril® 880 SAN resin for approximately one hour prior to the test run of the Magnum® 342EZ ABS automotive resin. Both canister and glass fiber filter samples were collected during the test run. The filter samples were used to determine if analytes were being lost through aerosol formation within the entrainment and manifold regions.

#### a) Canister and Filter Sample Collection.

Canister samples with and without in-line glass

fiber filters were collected and analyzed. Duplicate sets of samples were taken approximately 15 minutes after the extrusion process was initiated and again approximately 30 minutes after the process began. Ten canister samples were collected, including a sample from the port closest to the manifold inlet, and a background sample collected prior to the start of the extrusion process. Five filter samples were collected, including an additional glass fiber filter sample collected at the port closest to the manifold inlet, representing a 60-L total volume.

b) *Canister and Filter Sample Analysis*

The canister samples were analyzed within 24 hours using the GC/FID/MSD method described above.

The filter samples were extracted by sonication in methylene chloride and were analyzed by GC/MS. The filter extraction procedure involved placing the filter in a 6-dr vial with a PTFE lined cap. The filter was spiked with 20  $\mu$ L of at least one of the following as a recovery standard: 2000 ppm styrene- $d_8$ , 2000 ppm acetophenone- $d_8$ , or 2000 ppm ethylbenzene- $d_{10}$ , representing a concentration of 200 ppm in the final extract volume. Ten mL of methylene chloride were added to each vial. The vials were capped and shaken by hand several times. Each vial was sonicated for three minutes in one minute intervals, venting the cap as necessary. Each filter was rinsed with approximately 1 mL of methylene chloride and placed in a separate vial. The remaining solution was evaporated to approximately 1 mL and transferred to a 2 mL Chromoflex tube, and rinsed with an additional 1 mL of methylene chloride. The contents of the Chromoflex tube were concentrated under nitrogen to approximately 0.2 mL, final volume. The concentration of the internal standard, toluene- $d_8$ , was 100 ppm in each extract.

The filter extracts were analyzed by electron impact (EI) GC/MS on a Finnigan MAT 5100 Series GC/MS System using Finnigan MAT Automated GC/MS/DS Software Version 5.5.

*Phase 1: Manifold Spiking Test.* A spiking experiment with a calibration cylinder was conducted to determine if the gaseous emissions released from the extrusion of Magnum® 342EZ in the entrainment area were being adequately recovered at the sampling locations. A calibration cylinder containing the target compounds was prepared and a measured flow introduced into the entrainment area.

a) *Preparation of Surrogate Spiking Cylinder*

A mixture containing the deuterated and native species was prepared in a high pressure cylinder. The target analytes were obtained as gases or neat liquids (>99% purity) from Matheson or Aldrich Chemical Company. A 15.7-L compressed gas cylinder mixture

was prepared by injecting 5  $\mu$ L of each liquid and 1 cc of 1,3-butadiene gas into the cylinder, which had been previously flushed with high-purity nitrogen gas and evacuated. After injection of the compounds, the cylinder was pressurized to 1000 psig with ultra high-purity nitrogen (Matheson). Identification and elution order determination of the components were performed with the GC/FID/MSD by matching the mass spectrum acquired for each component to the NIST mass spectral library using the MSD data system search function. The calibration cylinder was used with a dual mass flow control assembly and humidified zero air to provide dilute mixtures to calibrate the GC/FID/MSD system.

b) *Sample Collection and Analysis*

The high pressure cylinder with the spiking mixture was connected to the entrainment area with a section of 1/8-in O.D. stainless steel tubing. The flow through the tubing was maintained at 10 L/min with a mass flow controller attached to the exit end of the cylinder regulator. Air flow in the entrainment zone was maintained at 700 L/min. Five canister samples were collected during this experiment. Duplicate canister samples were taken approximately 15 minutes after manifold equilibration and again approximately 30 minutes after equilibration. One canister sample was taken from the sampling port at the entrance to the sampling manifold to determine if manifold losses were occurring. A single glass fiber filter sample was collected for six minutes at a flow rate of 10 L/min at this same sampling port. The canister samples were analyzed by GC/FID/MSD. The filter sample was extracted and analyzed by GC/MS.

### Phase 2: Sampling and Analysis of Composite Resins

Phase 2 involved processing the four ABS composite resins using the conditions shown in Table 1. The general molding composite resin was processed twice to determine day-to-day variability of emission levels. For each test run, four canister samples were collected. Two samples were collected in duplicate, 15 minutes after the extrusion operation was initiated. The remaining two samples were collected 15 minutes later.

### RESULTS AND DISCUSSION

The results from the Phase 1 method validation study are discussed first and include the canister recovery test run, the filter analyses, and the spiked fume recovery test run. Secondly, the results are presented from the Phase 2 sampling and analysis of an air blank, SAN composite resins, and four ABS composite resins. The Phase 2 results focused on the following: 1) identifying and quantifying VOCs in

the exhaust and 2) comparing the in-line continuous FID monitor to the GC speciation methodology (GC/FID/MSD).

### VOC Recovery from the Canister

The canister-spiking experiment was conducted as part of the initial phase of the validation program to confirm the elution order of the target compounds and to assess the stability of these species in the canisters. The liquid spiked into the canister resulted in calculated concentrations ranging from 0.4 to 0.5  $\mu\text{g/L}$  for each target compound. A detection level of 0.01  $\mu\text{g/L}$  was obtained with this analytical method. The experimental concentrations in the canister were determined using the response factors calculated from direct GC analyses of the diluted mixtures of the calibration cylinder. Canister recoveries ranged from 112% for ethylbenzene to 171% for acetophenone, with an average recovery of 136%. The elevated values may be attributed to errors in preparing the original methanol solution or in spiking 5  $\mu\text{L}$  into the canister. The results demonstrate that all the compounds, with the exception of 2-phenyl-1-propanol, are well resolved and amenable to canister analyses. The compound 2-phenyl-1-propanol was not detected in the spiked canister. No further work was done with this compound.

### Filter Analysis Tests

Prior to analyzing the sample filters, an extraction blank and filter blanks were analyzed to validate the extraction method. The two filter blanks and the methylene chloride blank were spiked with deuterated recovery standards, extracted and concentrated as described in the experimental section.

The peak area for each deuterated standard was determined by integrating the ion trace for the base peak of each standard: styrene- $\text{d}_8$  at  $m/z$  112, acetophenone- $\text{d}_8$  at  $m/z$  110, and ethylbenzene- $\text{d}_{10}$  at  $m/z$  98. The expected concentration of the spiked standards in the final extract was 200 ppm for each species. Approximately 20% of styrene was lost in the extraction procedure and an additional 30% was lost on the filter for a total recovery of 50%. A comparison of the peak areas for acetophenone- $\text{d}_8$  and ethylbenzene- $\text{d}_{10}$  in the filter blanks versus the methylene chloride blank shows a similar trend for these compounds.

Based on the instrument response for the 200 ppm styrene- $\text{d}_8$  standard, the instrument detection limit was estimated at 10 ppm for styrene. Assuming that 50% of the styrene- $\text{d}_8$  was recovered, the estimated detection limit for the spiked filter was 20 ppm or 4  $\mu\text{g}/\text{filter}$ .

The recovery of styrene- $\text{d}_8$  from the sample filters exposed to ABS resin fumes was 5 to 15%, which is lower than the results for the unexposed spiked filters. Based on this observation, we estimate the method detection limit for the exposed filters at 200 ppm or 40  $\mu\text{g}/\text{filter}$  for each target analyte. A second extraction of the sample filter with methanol did not result in an increase in recovery.

No target analytes were found in the filter extracts during any of the ABS test runs. Based upon the results from the ABS auto resin, which showed gaseous styrene concentrations of 68.1  $\mu\text{g/L}$ , the fraction of this amount that could have been on the filter but below the 40  $\mu\text{g}/\text{filter}$  detection level is less than one percent. These results indicate that the glass fiber filters did not collect a significant amount of the target analytes as aerosols from the process emissions.

### Manifold Spiking Test

The results from the GC/FID/MSD analysis of the five canister samples collected during the manifold spiking experiment are summarized in Table 2. Two of the four compounds were deuterated ethylbenzene and styrene; the remaining two compounds, benzene and 4-vinyl-1-cyclohexene, were cylinder components not present in the gaseous emissions from the automotive test resin. The calculated spiking concentrations are listed first, followed by each of the canister results. All concentration levels were significantly above the detection level of 0.01  $\mu\text{g/L}$  (signal to noise ratio of 3 to 1). Individual recovery values for the four compounds are also shown for each canister sample. The values from the canister collected at the entrance of the manifold did not differ from the values from the remaining four canisters collected near the manifold's exit. Excellent recovery of the four analytes through the manifold was achieved. Average recovery and percent relative standard deviation (% RSD) values were: benzene, 114  $\pm$  2%; 4-vinyl-1-cyclohexene, 106  $\pm$  3%; ethylbenzene- $\text{d}_{10}$ , 115  $\pm$  16%; and styrene- $\text{d}_8$ , 89  $\pm$  11%.

**Table 2.** Calculated spiking concentration and percent recoveries of analytes found in canisters during the fume entrainment spiking experiment.

Compound	Calculated Spiking Conc. $\mu\text{g/L}$	Can 91-070 Direct $\mu\text{g/L}$	Can 88-007 (15 min) $\mu\text{g/L}$	Can 91-017 (Dup., 15 min) $\mu\text{g/L}$	Can 91-001 (30 min) $\mu\text{g/L}$	Can 91-025 (Dup., 30 min) $\mu\text{g/L}$
benzene	0.07	106	117	114	117	117
4-vinyl-1-cyclohexene	0.06	101	107	107	107	107
ethylbenzene- $\text{d}_{10}$	0.07	111	145	101	120	98
styrene- $\text{d}_8$	0.08	87	96	84	99	78

nd = not detected (<0.01  $\mu\text{g/L}$ ). Dup. = Duplicate.

### Air Blank and SAN Purging Resin Tests

An air sample (blank) collected from the manifold prior to extrusion of the resins resulted in very low levels of the following target analytes: styrene, 1.82 µg/L; ethylbenzene, 0.63 µg/L; acrylonitrile, 0.23 µg/L; isopropylbenzene, 0.09 µg/L; n-propylbenzene, 0.05 µg/L and acetophenone, 0.01 µg/L. No other target analytes were detected.

The SAN purging resin was extruded and samples collected between the composite resin tests. Seven of the nine target analytes were detected. Listed below are the target analytes, mean levels detected, and % RSD: acrylonitrile 2.79 µg/L±12%, ethylbenzene 5.36 µg/L±16%, styrene 18.7 µg/L±12.6%, isopropylbenzene 0.71 µg/L±0.18%, n-propylbenzene 0.485 µg/L±15.5%, methyl styrene 0.235 µg/L±87%, and acetophenone 0.365 µg/L±31%. The SAN purge samples did not indicate any significant carryover from the previously extruded composite resin.

### ABS Composite Resin Tests

Table 3 summarizes the results of analyzing the gaseous emissions from the processing of four ABS composite resins. For each composite resin, there are four data points (e.g., four canister samples). The mean concentration for each of the nine target compounds is shown, along with the total of the nine species, the total of all identified and unidentified GC species, and finally, the total VOCs determined by the Beckman 402 analyzer. Values less than 0.01 µg/L were listed as not detected. Percent relative standard deviation (% RSD) values are also reported.

The following observations were made. First, 1,3-butadiene was found only in the pipe and automotive composite exhaust at levels of 0.97 and 0.48 µg/L, respectively. All other target analytes were detected in the emissions from all four

**Table 3.** Concentration detected in the emissions of extruded ABS composite resins.

Compound	Auto µg/L	GM µg/L	GM-R µg/L	PIPE µg/L	Refrig µg/L
1,3-butadiene	0.48	ND	ND	0.97	ND
acrylonitrile	3.00	3.84	4.33	4.74	5.67
4-vinyl-1-cyclohexene	0.26	1.09	0.90	6.50	1.51
ethylbenzene	14.40	5.21	4.45	33.70	7.61
styrene	68.10	86.00	69.90	196.00	85.60
isopropylbenzene	1.72	1.89	1.49	10.80	1.39
n-propylbenzene	1.24	1.09	0.92	5.15	0.93
methyl styrene	0.07	11.50	7.46	30.40	2.27
acetophenone	1.45	8.87	5.16	35.10	2.33
Total of target analytes (GC/FID)	90.72	119.5	94.61	323.4	107.3
Total VOCs by GC/FID	99	129	103	318	126
Total VOCs by 402 analyzer	104	120	105	285	123

ND = Not detected (<0.01 µg/L).

composite resins, except for 2-phenyl-1-propanol, which as mentioned earlier, was not amenable to the canister methodology. The pipe composite emissions contained the highest level of all the detectable target analytes except for acrylonitrile, which was slightly higher in the refrigeration composite resin exhaust.

The sum of the concentrations of the nine identified target species accounts for over 90% of the total concentration determined by the GC/FID speciation methodology. In addition to the target analytes, the composite fumes contained six tentatively identified compounds, m- and p-xylene, o-xylene, benzaldehyde, 1-methyl-2-isopropylbenzene, p-ethylstyrene, and 1-methylene-4-isopropylene cyclohexane. The 1-methylene-4-isopropylene cyclohexane was present at significant levels in the general molding and refrigeration composite fumes. This compound was present at levels approximately 20-30% of the styrene concentration, based on the relative chromatographic response.

Figure 3 shows a representative chromatogram from one of the GC/MSD analyses of the general molding composite resin exhaust. The assigned chromatographic peak numbers correspond to the target analytes and tentatively identified compounds detected.

The results in Table 3 also indicate that the concentration levels detected in the exhaust by the in-line Beckman 402 analyzer compared very favorably with those values found with the GC/FID methodology. In all cases the differences in reported concentrations were less than 10%. Since oxygenated compounds will give a lower FID response than benzene (which was used to calibrate the Beckman analyzer), a compound response adjustment should be made to the reported oxygenated species in order to more fairly compose the total concentrations reported by the two methods. However, since the oxygenated fraction of each GC run was minor (i.e., 1% to 10%), an oxygenated response adjustment would not significantly change the total GC speciation results. Results from the continuous in-line VOC analyzer were also useful in determining that the emission and entrainment of the fumes were stable throughout the collection period. The continuous VOC analyzer was also used during the validation phase of the program to demonstrate that no concentration gradients were occurring at sampling locations 1 and 2 (Figure 1) or at the inlet and outlet of the sampling manifold (Figure 2).

The precision values (% RSD) for the data in Table 3 for each measured component ranged from less than 1% to approximately 59%. For most components, the precision was better than 10%. We consider these values to be very acceptable. The main contribution to sample variability was the fact that canister samples were collected at various time intervals over a 30-min test period.

Finally, using the concentration data in Table 3 and the extruder operating conditions shown in Table 1, emission factors have been derived for the various species, in terms of micrograms of VOC emitted per gram of

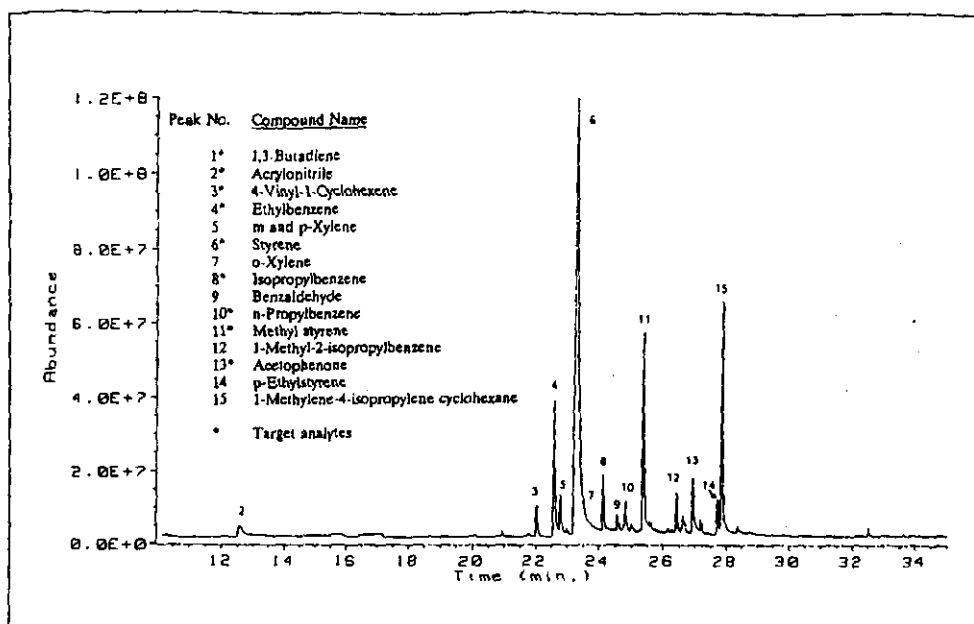

Figure 3. GC/MSD chromatogram of a canister sample during the extrusion of general molding composite resin.

processed resin. Table 4 shows these results for the four composite resins. Mean values of the target analytes were also calculated for the two general molding resin test runs. The precision (% RSD) values indicate that day-to-day variability in resin processing was less than 20% for most of the target analytes.

**SUMMARY OF STUDY FINDINGS**

Emission levels were determined for the process of extruding ABS composite resins. Four composite resins were tested, representing automotive, general moldings, pipe, and refrigeration applications.

A method validation was performed in Phase 1. This involved the verification of the recovery of target analytes spiked into a sampling canister. All target analytes were detected except for 2-phenyl-1-propanol, which could not be determined using this method. An average recovery of 136% for the canister spike was found. The elevated recovery may be attributed to the use of a methanol solution to spike analytes into the canister (e.g., possibly evaporation of methanol during standard preparation procedures) or the small volume used in spiking. Although this is a standard technique for preparation of spiked canisters, it may not have been optimal for these compounds. The recovery of surrogate compounds spiked into the exhaust generated during the extrusion process was also determined. This involved the introduction of a surrogate gas mixture from a compressed cylinder into the entrainment area of the extruder while the extrusion of Magnum® 342EZ ABS automotive resin was being performed. An excellent average recovery of 106% was obtained for the four surrogate compounds, indicating that this method of collection and analysis was acceptable.

Phase 2 involved collecting and analyzing samples from tests which included four composite resins, one replicate resin, an air blank, and two SAN purge blanks. All target analytes were detected, except for 2-phenyl-1-propanol. Pipe and automotive composite fumes were the only composites to generate 1,3-butadiene, with emission factors of 1.99 and 0.93 µg/g, respectively. The pipe composite fume yielded the highest emission factor for styrene at 402 µg/g and the highest total VOC emission factors deter-

mined by GC/FID and the continuous VOC analyzer at 653 and 544 µg/g, respectively. Also, the trends in the level of the target analytes detected by the 402 analyzer were consistent with the trends seen in the canister analyses.

The duplicate analyses of the composite fume samples were reproducible with precision for most of the target analytes between 1% and 20%. The general molding replicate run showed day-to-day variability of approximately 20% RSD for the target analytes. The range of the %RSD for the replicate and duplicates was considered acceptable.

Table 4. ABS composite resin emission factors.

Compound	Auto µg/g	GM (R) µg/g	GM Mean ± % RSD	Pipe µg/g	Refrig µg/g
1,3-butadiene	0.93	nd	nd	1.99	nd
acrylonitrile	5.74	7.79	7.3 ± 8.77	9.75	10.4
4-vinyl-1-cyclohexene	0.50	1.61	1.78 ± 13.5	13.4	2.76
ethylbenzene	27.6	8.02	8.68 ± 10.7	69.20	13.9
styrene	130	126	140 ± 14.2	402	156
isopropylbenzene	3.29	2.68	3.03 ± 16.2	22.2	2.55
n-propylbenzene	2.37	1.65	1.80 ± 11.7	10.6	1.70
methyl styrene	1.29	13.43	17.0 ± 29.4	62.41	4.16
acetophenone	2.78	9.29	12.6 ± 36.9	72.1	4.25
Total VOCs by GC/FID	190	185		653	231
Total VOCs by 402	199	189		544	225

ANALYZER

NOTES  
 nd = not detected (<0.01 µg/L).  
 % RSD = Percent relative standard deviation.  
 GM = General molding  
 Refrig. = Refrigeration.  
 (R) = Replicate.  
 VOC = Volatile Organic Compounds found in each resin sample.

In addition to the target analytes, the composite fumes contained six tentatively identified compounds: m- and p-xylene, o-xylene, benzaldehyde, 1-methyl-2-isopropylbenzene, p-ethylstyrene, and 1-methylene-4-isopropylene cyclohexane. The 1-methylene-4-isopropylene cyclohexane was present at significant levels in the fumes from the general molding and refrigeration composite resins.

#### ACKNOWLEDGMENTS

We would like to thank Battelle researchers Mr. R. N. Smith, Mr. G.W. Keigley, Ms. M. E. Schrock, Mr. J. Frye, and Mr. M. J. Brooker for their technical expertise and dedication in the sampling design and collection and analysis of the emission samples. In addition, we would like to thank Mr. R.C. Brooke of GE Plastics, Mr. V. L. Rhodes of Monsanto Chemical, and Dr. M. L. Rainey of Dow Chemical Company for their help in designing the experiments and sponsoring the study.

#### REFERENCES

1. Spicer, C.W.; Holdren, M.W.; Miller, S.E.; Smith, D.L.; Smith, R.N.; Kuhlman, M. R.; Hughes, D. P. *Aircraft Emissions Characterization: TF41-A2, TF30-P103, TF30-P109 Engines*; Report ESL-TR-87-27; Tyndall AFB, FL, March 1988. Available from NTIS as ADA192053.
2. Spicer, C.W.; Holdren, M.W.; Miller, S. E.; Smith, D. L.; Hughes, D. P. *Aircraft Emissions Characterization*; Report ESL-TR-87-63; Tyndall AFB, FL, March 1988. Available from NTIS as ADA197864.

3. Plastic Fumes program - Phases 1 through 6, Battelle Interim Reports to Plastic Technology Division, General Electric Company, June, 1984.
4. Winberry, W.T., Jr.; Murphy, N.T.; Riggan, R. M. "Method TO-14"; In *Compendium of Methods for the Determination of Toxic Organic Compounds in Ambient Air*; U.S. Environmental Protection Agency. Research Triangle Park, NC, 1988. Available from NTIS as PB90-127374.

#### About the Authors

D. A. Contos, M.S., is a Principal Research Scientist in the Health Division at Battelle Memorial Institute. M. W. Holdren, M.S., is a Senior Research Scientist and D. L. Smith, B.S., is a Researcher in the Environmental Systems and Technology Division at Battelle Memorial Institute, 505 King Avenue, Columbus, Ohio 43201. R. L. Brooke, M.S., is Manager of Product Safety and Regulatory Affairs at GE Plastics, Parkersburg, West Virginia. M. L. Rainey, Ph.D., is Manager of Health, Environmental and Regulatory Affairs at Dow Plastics, Dow Chemical Company, Midland, Michigan. V. L. Rhodes, M.S., is Manager of Product Safety at Monsanto Company, St. Louis, Missouri.

## International Specialty Conference **Continuous Compliance Monitoring Under the Clean Air Act Amendments**

**October 25-27, 1995  
Hyatt Regency Hotel  
Chicago, Illinois**

For conference information contact:  
**Debbie Fair, A&WMA registrar,  
(412) 232-3444.**

For exhibition information contact:  
**Hans Brouwers,  
EPM Environmental, Inc.,  
(708) 255-4494.**



**AIR & WASTE MANAGEMENT  
ASSOCIATION**

◆  
SINCE 1907

## SPI STUDIES EMISSION FACTOR SUMMARY CHART

Study	Resin	(1)	(1)	(2)	(2)	(3)	(3)
		VOM (ug/g)	VOM (lb/ton)	HAP (ug/g)	HAP (lb/ton)	PM (ug/g)	PM (lb/ton)
polyethylene June 1996	LDPE - 500 F	35	0.07	0.39	0.0008	31	0.06
	LDPE - 600 F	157	0.31	21	0.0420	242	0.48
	LLDPE - 355 F	8	0.02	0.12	0.0002	2	0.00
	LLDPE - 395 F	9	0.02	0.07	0.0001	22	0.04
	LLDPE - 450 F	14	0.03	0.27	0.0005	25	0.05
	LLDPE - 500 F	20	0.04	0.45	0.0009	60	0.12
	HDPE - 380 F	21	0.04	0.15	0.0003	20	0.04
	HDPE - 430 F	31	0.06	0.15	0.0003	27	0.05
polypropylene Jan 1999	homopolymer - 400 F	104	0.21	1.4	0.0028	30	0.06
	homopolymer - 510 F	177	0.35	2.3	0.0046	68	0.14
	(4) homopolymer - 605 F	819	1.64	47	0.0940	653	1.31
	homopolymer - 490 F	191	0.38	5.5	0.0110	150	0.30
	RG homopolymer - 490 F	33	0.07	0.35	0.0007	17	0.03
	RG homopolymer - 570 F	202	0.40	19	0.0380	218	0.44
	copolymer - 505 F	80	0.16	1.4	0.0028	35	0.07
	copolymer - 510 F	59	0.12	0.23	0.0005	28	0.06
polyamide July 2001	general nylon 66	50	0.10	0	0.00000	104	0.21
	general nylon 6	65	0.13	0.01	0.00002	24	0.05
	general nylon 6	52	0.10	0.01	0.00002	18	0.04
	copolymer nylon 66/6	122	0.24	0.01	0.00002	6	0.01
	copolymer nylon 66/6	154	0.31	0.01	0.00002	3	0.01
	EPDM toughened nylon 66	137	0.27	0.32	0.00064	67	0.13
	EPDM toughened nylon 66	133	0.27	0.29	0.00058	64	0.13
	toughened nylon 6	171	0.34	2.9	0.00580	27	0.05
	toughened nylon 6	158	0.32	2.8	0.00560	25	0.05
	(5) nylon 66	57	0.11	0.01	0.00002	115	0.23
	(5) copolymer nylon 66/6	61	0.12	0.01	0.00002	92	0.18
	(5) copolymer nylon 66/6	101	0.20	0.01	0.00002	55	0.11
(5) copolymer nylon 66/6	102	0.20	0.01	0.00002	76	0.15	
polycarbonate July 2002	food contact grade	39	0.08	31	0.062	8.5	0.02
	food contact grade	37	0.07	32	0.064	9	0.02
	compact disc grade	21	0.04	22	0.044	13	0.03
	compact disc grade	23	0.05	24	0.048	13	0.03
	UV stabilized grade	38	0.08	43	0.086	29	0.06
	UV stabilized grade	40	0.08	49	0.098	31	0.06
	radiation stabilized grade	71	0.14	58	0.116	8	0.02
	radiation stabilized grade	62	0.12	58	0.116	6	0.01
	impact modified grade	116	0.23	114	0.228	21	0.04
	impact modified grade	109	0.22	115	0.230	18	0.04
	(5) ignition resistant grade	19	0.04	7	0.014	9	0.02
	(5) ignition resistant grade	20	0.04	9	0.018	10	0.02
	radiation stabilized grade	14	0.03	0.5	0.001	23	0.05
	radiation stabilized grade	15	0.03	0.6	0.001	23	0.05
	branched polymer	11	0.02	0.6	0.001	31	0.06
	branched polymer	11	0.02	0.72	0.001	33	0.07
	copolymer	119	0.24	139	0.278	139	0.28
	copolymer	115	0.23	118	0.236	139	0.28

**NOTES:** (1) VOM = volatile organic material (Illinois EPA term for volatile organic matter - VOC)

June 1996 and Jan. 1999 studies utilized a Beckman 402 in-line FID system.

July 2001 study utilized a VIG Industries Model 20 total HC analyzer with HFID.

July 2002 study utilized a Fisons MD 800 GC system with FID and MSD detectors.

(2) HAP = hazardous air pollutant

(3) PM = particulate matter

(4) All emission factors determined for this material are considered "outliers" and not relevant since material was processed at extreme temperature (605 F) for evaluation purposes only.

(5) Contained flame retardant additive.

## ESTIMATED EMISSIONS USING A RANGE OF EMISSION FACTORS AND THROUGHPUTS

### Volatile Organic Material (VOM) Emissions

#### *Low Emission Factor, Low Throughput*

$$10 \text{ lb resin / hour} \times \text{ton resin} / 2,000 \text{ lb resin} \times 0.1 \text{ lb VOM / ton resin} = 0.00050 \text{ lb VOM / hr}$$

$$0.00050 \text{ lb VOM / hr} \times \text{ton VOM} / 2,000 \text{ lb VOM} \times 8,760 \text{ hr / yr} = 0.002 \text{ ton VOM / yr}$$

#### *High Emission Factor, High Throughput*

$$200 \text{ lb resin / hour} \times \text{ton resin} / 2,000 \text{ lb resin} \times 0.4 \text{ lb VOM / ton resin} = 0.04 \text{ lb VOM / hr}$$

$$0.04 \text{ lb VOM / hr} \times \text{ton VOM} / 2,000 \text{ lb VOM} \times 8,760 \text{ hr / yr} = 0.2 \text{ ton VOM / yr}$$

### Hazardous Air Pollutant (HAP) Emissions

#### *Low Emission Factor, Low Throughput*

$$10 \text{ lb resin / hour} \times \text{ton resin} / 2,000 \text{ lb resin} \times 0.00002 \text{ lb HAP / ton resin} = 0.0000001 \text{ lb HAP / hr}$$

$$0.0000001 \text{ lb HAP / hr} \times \text{ton HAP} / 2,000 \text{ lb HAP} \times 8,760 \text{ hr / yr} = 0.0000004 \text{ ton HAP / yr}$$

#### *High Emission Factor, High Throughput*

$$200 \text{ lb resin / hour} \times \text{ton resin} / 2,000 \text{ lb resin} \times 0.3 \text{ lb HAP / ton resin} = 0.03 \text{ lb HAP / hr}$$

$$0.03 \text{ lb HAP / hr} \times \text{ton HAP} / 2,000 \text{ lb HAP} \times 8,760 \text{ hr / yr} = 0.1 \text{ ton HAP / yr}$$

### Particulate Matter (PM) Emissions

#### *Low Emission Factor, Low Throughput*

$$10 \text{ lb resin / hour} \times \text{ton resin} / 2,000 \text{ lb resin} \times 0.02 \text{ lb PM / ton resin} = 0.0001 \text{ lb PM / hr}$$

$$0.0001 \text{ lb PM / hr} \times \text{ton PM} / 2,000 \text{ lb PM} \times 8,760 \text{ hr / yr} = 0.0004 \text{ ton PM / yr}$$

#### *High Emission Factor, High Throughput*

$$200 \text{ lb resin / hour} \times \text{ton resin} / 2,000 \text{ lb resin} \times 0.5 \text{ lb PM / ton resin} = 0.05 \text{ lb PM / hr}$$

$$0.05 \text{ lb PM / hr} \times \text{ton PM} / 2,000 \text{ lb PM} \times 8,760 \text{ hr / yr} = 0.2 \text{ ton PM / yr}$$

Abbreviations: hr = hour, lb = pound, yr = year



**OVERVIEW OF ESTIMATED EMISSIONS**

Volatile Organic Material (VOM) Emissions

*Low Emission Factor, Low Throughput*

0.002 ton VOM / yr

*High Emission Factor, High Throughput*

0.2 ton VOM / yr

Hazardous Air Pollutant (HAP) Emissions

*Low Emission Factor, Low Throughput*

0.0000004 ton HAP / yr

*High Emission Factor, High Throughput*

0.1 ton HAP / yr

Particulate Matter (PM) Emissions

*Low Emission Factor, Low Throughput*

0.0004 ton PM / yr

*High Emission Factor, High Throughput*

0.2 ton PM / yr

Abbreviations: hr = hour, lb = pound, yr = year

**ATTACHMENTS**

- A. 2002 Economic Census, Manufacturing Industry Series, "All Other Plastics Product Manufacturing: 2002.," US Census Bureau, EC02-311-326199 (RV), December 2004; page 17.
- B. "State-by-State Guide to Resin and Equipment," p. A-2; SPI Plastics Data Source (2001).
- C. "2005 Survey of North American Injection Molders," *Plastics News*, April 11, 2005.
- D. Rosato, D.V. & Rosato, M.G. (2000). *Injection Molding Handbook*. New York: Springer.
- E. Forrest, M.J., Jolly, A.M., Holding, S.R., and Richards, S.J. (1995). "Emissions from Processing Thermoplastics," *Annals of Occupational Hygiene*, 39 (1), 35-53.

# All Other Plastics Product Manufacturing: 2002

Issued December 2004

EC02-311-326199 (RV)

## 2002 Economic Census

*Manufacturing*

Industry Series



**U.S. Department of Commerce**  
**Donald L. Evans,**  
Secretary

**Theodore W. Kassinger,**  
Deputy Secretary

**Economics and Statistics Administration**  
**Kathleen B. Cooper,**  
Under Secretary for  
Economic Affairs

**U.S. CENSUS BUREAU**  
**Charles Louis Kincannon,**  
Director

**Table 2. Industry Statistics for Selected States: 2002**

[States that are a disclosure or with less than 100 employees are not shown. Data based on the 2002 Economic Census. For information on confidentiality protection, nonsampling error, explanation of terms, and geographical definitions, see note at end of table. For information on geographic areas followed by \*, see Appendix D. For meaning of abbreviations and symbols, see introductory text]

Industry and geographic area	All establishments <sup>2</sup>		All employees		Production workers			Value added (\$1,000)	Total cost of materials (\$1,000)	Total value of shipments (\$1,000)	Total capital expenditures (\$1,000)	
	E1	Total	With 20 employees or more	Number <sup>3</sup>	Payroll (\$1,000)	Number <sup>3</sup>	Hours (1,000)					Wages (\$1,000)
<b>326199. All other plastics product manufacturing</b>												
United States.....	1	7 847	3 944	488 278	15 035 083	378 110	746 815	9 680 220	40 852 050	32 073 072	72 893 593	13 304 805
Alabama.....	-	73	38	5 691	164 815	4 686	8 575	119 951	368 451	421 412	787 856	46 400
Arizona.....	1	116	48	5 176	180 517	3 854	7 466	93 944	398 890	292 351	685 637	29 074
Arkansas.....	1	77	45	5 532	137 452	4 475	8 979	90 735	450 061	372 944	816 945	35 120
California.....	1	958	417	44 414	1 410 428	32 817	65 856	810 269	3 727 912	2 752 523	6 480 958	221 274
Colorado.....	3	107	37	3 187	102 755	2 359	4 735	60 330	250 541	161 926	415 310	13 805
Connecticut.....	2	121	51	5 292	171 254	4 256	8 423	112 967	408 988	322 050	731 429	35 609
Delaware.....	-	17	11	1 019	34 537	725	1 451	18 022	92 039	95 738	187 392	2 851
Florida.....	2	323	97	8 460	249 033	6 588	13 047	162 000	691 853	444 788	1 138 559	35 569
Georgia.....	1	174	99	10 827	306 608	8 222	16 592	204 949	846 010	760 866	1 610 592	73 926
Idaho.....	-	42	9	793	20 572	620	1 284	14 532	85 094	47 662	131 562	5 985
Illinois.....	1	484	278	36 900	1 195 294	28 222	56 832	747 867	3 407 828	2 683 953	6 126 262	228 963
Indiana.....	1	307	187	26 206	808 725	19 957	40 377	551 043	2 158 144	1 604 529	3 742 476	180 435
Iowa.....	1	82	50	5 840	155 583	5 054	9 937	118 631	427 161	370 619	797 750	30 866
Kansas.....	1	73	36	6 229	191 542	5 124	10 388	133 764	636 174	441 678	1 072 437	36 656
Kentucky.....	2	97	65	9 956	272 472	7 844	15 166	191 542	771 725	699 870	1 473 172	31 883
Louisiana.....	2	49	19	1 483	43 952	1 047	2 198	24 351	97 637	102 613	198 176	10 711
Maine.....	1	23	10	1 002	30 387	829	1 674	20 023	139 361	72 847	212 784	7 823
Maryland.....	2	68	38	5 374	179 343	3 981	6 869	105 962	626 430	332 619	954 082	101 178
Massachusetts.....	1	221	110	12 004	369 145	9 179	16 433	230 916	1 212 499	752 006	1 966 748	81 708
Michigan.....	1	544	327	47 852	1 512 041	37 294	74 292	969 305	4 139 078	3 417 495	7 568 035	253 662
Minnesota.....	2	214	105	12 714	413 828	9 717	19 405	263 549	1 060 337	661 426	1 704 648	82 754
Mississippi.....	1	55	29	3 228	88 866	2 835	4 814	59 711	257 038	245 629	500 953	26 954
Missouri.....	1	153	74	11 518	331 139	8 884	16 894	214 515	790 899	717 162	1 525 997	128 440
Nebraska.....	2	39	22	2 916	83 892	2 315	4 624	55 606	196 149	165 662	358 567	38 235
Nevada.....	1	51	19	1 334	37 195	1 067	2 220	26 613	106 992	86 302	193 445	14 326
New Hampshire.....	1	51	20	3 476	116 457	2 676	5 247	73 570	225 581	177 007	401 450	15 783
New Jersey.....	2	275	137	15 699	479 886	11 681	23 471	283 863	1 108 566	931 449	2 047 579	65 942
New York.....	3	366	158	16 043	509 127	12 439	24 625	312 257	1 240 383	851 795	2 083 415	68 633
North Carolina.....	2	200	116	13 331	394 177	10 598	20 405	261 858	1 233 995	893 643	2 116 080	112 144
Ohio.....	1	558	332	46 458	1 378 382	36 127	71 554	937 429	3 802 023	3 230 617	7 016 962	376 195
Oklahoma.....	2	62	20	2 822	84 314	1 875	3 659	47 849	287 905	205 628	494 424	20 333
Oregon.....	1	100	33	3 953	120 480	3 033	6 053	74 303	326 824	223 511	548 859	13 970
Pennsylvania.....	1	356	210	26 901	837 089	21 249	43 050	553 702	2 164 607	1 605 380	3 757 245	172 785
Rhode Island.....	2	53	27	2 518	81 679	1 847	3 894	50 969	173 778	108 188	284 123	15 536
South Carolina.....	1	101	57	7 568	244 275	8 022	12 073	159 581	774 202	603 494	1 376 227	73 298
South Dakota.....	1	22	9	843	15 949	529	1 066	12 192	36 446	21 312	57 286	11 886
Tennessee.....	1	164	103	12 777	376 788	10 170	20 196	250 206	1 052 699	967 169	2 018 410	149 730
Texas.....	2	414	185	20 469	585 673	16 607	30 958	399 929	1 483 531	1 535 039	3 029 012	117 965
Utah.....	3	71	28	2 117	61 108	1 683	3 300	41 485	150 311	100 436	247 158	7 585
Vermont.....	4	24	11	1 286	41 843	1 024	2 055	26 316	118 512	73 896	189 985	7 929
Virginia.....	-	80	51	11 409	401 659	8 148	17 287	253 403	1 194 230	794 662	1 991 282	47 297
Washington.....	2	126	59	8 060	192 410	4 810	9 273	123 469	583 751	435 073	1 014 182	34 450
West Virginia.....	-	23	10	2 156	64 310	1 554	3 075	34 440	160 900	135 181	304 459	10 005
Wisconsin.....	1	268	143	16 776	541 255	13 221	25 015	358 429	1 298 314	1 093 113	2 386 012	114 027

<sup>1</sup>Some payroll and sales data for small single-establishment companies with up to 20 employees (cutoff varied by industry) were obtained from administrative records of other government agencies rather than from census report forms. These data were then used in conjunction with industry averages to estimate statistics for these small establishments. This technique was also used for a small number of other establishments whose reports were not received at the time data were tabulated. The following symbols are shown where estimated data account for 10 percent or more of the figures shown: 1-10 to 19 percent; 2-20 to 29 percent; 3-30 to 39 percent; 4-40 to 49 percent; 5-50 to 59 percent; 6-60 to 69 percent; 7-70 to 79 percent; 8-80 to 89 percent; 9-90 percent or more.

<sup>2</sup>Includes establishments with payroll at any time during the year.

<sup>3</sup>Number of employees figures represent average number of production workers for pay period that includes the 12th of March, May, August, and November plus other employees for payroll period that includes the 12th of March.

Note: The data in this table are based on the 2002 Economic Census. To maintain confidentiality, the Census Bureau suppresses data to protect the identity of any business or individual. The census results in this table contain nonsampling errors. Data users who create their own estimates using data from American FactFinder tables should cite the Census Bureau as the source of the original data only. For explanation of terms, see Appendix A. For full technical documentation, see Appendix C. For geographical definitions, see Appendix D.



## **Plastics Data Source**

The Size and Impact of the  
Plastics Industry

Equipment Statistics Annual  
and Quarterly Reports

Plastics End-Market  
Snapshots

Financial Management  
Surveys

Equipment Statistics Annual  
and Quarterly Reports

Plastics End-Market  
Snapshots

Financial Management  
Surveys

## State-by-State Guide to Resin and Equipment



Prepared for SPI by

Probe Economics, Inc.  
358 Saw Mill River Road  
P.O. Box 660  
Millwood, NY 10546  
Phone 914 . 923 . 4505

October 12, 2001

[www.plasticsdatasource.org](http://www.plasticsdatasource.org)

© 2001 The Society of the Plastics Industry, Inc.  
All rights reserved. Catalog no. AB-148

## List of Tables

<u>Table Number</u>	<u>Description</u>	<u>Page</u>
1	Combined Resin Ranking by State	18
2	Combined Machine Ranking by State	27
3	Combined Facility Rank ing by State	36
A - 1	Resin Consumption, Millions of Pounds	A - 1
A - 2	Facilities	A - 2
A - 3	Machines	A - 3
A - 4	Comparisons with Employment Data	A - 4

FACILITIES

State	Blow Molding	Rotational Molding	Film & Sheet Extrusion	Pipe Extrusion	Profile Extrusion	Injection Molding	Compounding	Other	Total
U.S. Total	1,188	302	1,281	326	802	7,727	703	577	12,906
U.S. Total, including P.R.	1,191	302	1,281	326	802	7,733	704	577	12,916
Alabama	18	4	13	9	17	62	9	15	147
Alaska	NA	NA	NA	NA	NA	NA	NA	NA	0
Arizona	14	1	8	6	3	82	3	6	123
Arkansas	16	5	18	10	10	84	4	9	156
California	136	38	159	41	65	980	61	48	1,528
Colorado	7	7	8	4	11	118	2	3	160
Connecticut	10	1	15	2	6	190	11	20	255
Delaware	2	1	4	1	2	10	3	3	26
District of Columbia	NA	NA	NA	NA	NA	NA	NA	NA	0
Florida	44	7	31	18	37	323	16	23	499
Georgia	37	10	58	9	24	120	33	52	343
Hawaii	3	1	1	NA	NA	2	1	0	8
Idaho	0	4	0	2	2	28	1	1	38
Illinois	88	11	85	10	47	491	40	27	797
Indiana	38	16	47	6	35	326	40	21	529
Iowa	29	13	15	6	8	89	1	2	163
Kansas	16	3	10	10	13	60	4	7	123
Kentucky	26	1	29	7	6	127	15	5	216
Louisiana	16	NA	9	3	3	24	12	4	71
Maine	3	1	2	NA	3	26	3	5	43
Maryland	15	2	7	1	3	60	7	1	96
Massachusetts	38	6	49	5	22	260	33	41	454
Michigan	47	10	40	4	52	633	30	10	826
Minnesota	29	20	32	8	20	182	15	2	308
Mississippi	7	2	17	3	10	64	9	10	122
Missouri	45	7	25	5	22	146	7	8	265
Montana	1	NA	0	NA	NA	12	NA	0	13
Nebraska	2	3	3	5	3	48	4	2	70
Nevada	1	1	3	7	4	28	2	0	46
New Hampshire	12	3	4	3	8	67	6	12	115
New Jersey	46	7	70	7	38	245	38	21	472
New Mexico	3	NA	0	1	NA	7	NA	0	11
New York	55	10	46	12	31	354	27	17	552
North Carolina	34	11	47	10	32	218	22	33	407
North Dakota	1	1	1	1	NA	10	NA	0	14
Ohio	90	28	78	21	75	542	67	22	923
Oklahoma	11	5	12	4	1	57	4	1	95
Oregon	8	5	9	7	6	87	3	3	128
Pennsylvania	58	11	58	19	40	357	39	21	603
Rhode Island	2	1	11	1	5	56	4	8	88
South Carolina	19	6	20	8	12	92	9	30	196
South Dakota	1	2	4	NA	NA	18	NA	0	25
Tennessee	25	4	30	3	23	171	18	8	282
Texas	62	13	84	26	43	352	62	38	680
Texas	10	6	5	3	3	86	2	4	119
Utah	10	6	5	3	1	23	1	6	38
Vermont	2	NA	5	NA	1	86	2	4	119
Virginia	14	2	30	4	18	62	9	17	156
Washington	16	6	17	5	11	90	5	4	154
West Virginia	6	1	5	4	1	10	5	1	33
Wisconsin	27	5	57	5	26	240	16	6	382
Wyoming	0	0	0	0	0	8	0	0	8
Puerto Rico	3	0	0	0	0	6	1	0	10

SPECIAL REPORT

# INJECTION MOLDING

Battenfeld of America Inc. photo

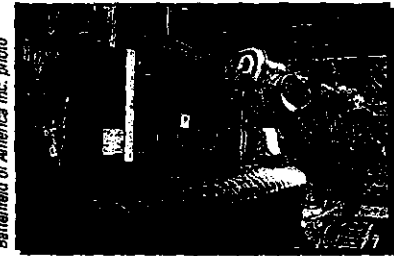

**2005 processor ranking**  
 Thermoforming-Feb. 21  
 Pipe, profile & tubing-June 20  
 Rotomolding-Aug. 15  
 Film & sheet manufacturing-Sept. 12  
 Blow molding-Nov. 7  
 Market Data Book-Dec. 26

## 2005 survey of North American injection molders

### Top 100 molders' markets & materials

- Top five end markets\***
1. Automotive
  2. Consumer products
  3. Electrical/electronics
  4. Medical/pharmaceutical
  5. Containers/closures
- Top five materials**
1. Polypropylene
  2. ABS
  3. Polycarbonate
  4. HDPE
  5. Nylon

**Total sales: \$30.3 billion**

(655 companies)



**Total plants: 1,377**

**Total presses: 29,911**

### Top plant sites & in-house services

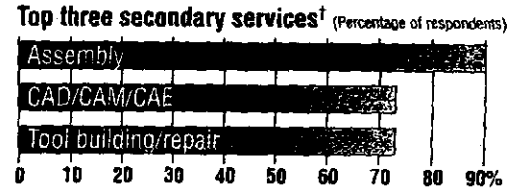
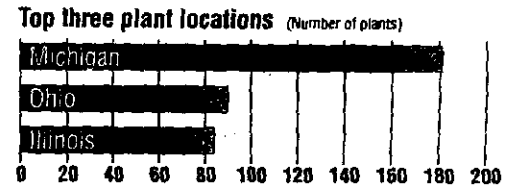

†Three companies did not respond

Source: *Plastics News* \*General industrial category excluded

Plastics News graphic by Scott Merryweather





Site search  
Search tips

GO

PLASTICS NEWS  
CONTENT

- News / Home ▶
- Opinion
- Resin pricing ▶
- Ranking & lists ▶
- Resin Selector
- FYI charts
- Calendar
- Links directory
- Product news
- Processor award
- K 2004
- Contact us
- About us
- Site map

PN EVENTS

- Executive Forum
- Encounters ▶

SERVICES

- Classified ads
- Subscribe ▶
- E-mail products ▶
- Edt. calendar ▶
- Advertising
- Lit spotlight
- PN Ad Connect
- List rental ▶
- Story reprints

## Rankings & lists

[Click here to purchase rankings](#)

# INJECTION MOLDERS

Ranked by sales of injection molded products in most recent full fiscal year  
Originally published April 11, 2005, in *Plastics News*. Some data may have been updated.

Rank	Company	Top injection molding official	Injection molding sales (millions \$)
1	<a href="#">Collins &amp; Aikman Corp.</a> (P) Troy, MI	<b>Charles Becker</b> Acting CEO	1,600.00 <sup>E</sup>
2	<a href="#">Delphi Corp.</a> (P) Troy, MI	<b>Kevin Heigel</b> Business line executive	1,441.00
3	<a href="#">Visteon Corp.</a> (P) Van Buren Township, MI	<b>Tom Burke</b> VP, North American mfg. operations	1,350.00 <sup>E</sup>
4	<a href="#">Lear Corp.</a> (P) Southfield, MI	<b>Lou Salvatore</b> President, interiors & electrical	1,100.00
5	<a href="#">Plastech Engineered Products Inc.</a> <sup>a</sup> Dearborn, MI	<b>Julie Brown</b> Chairwoman & CEO	830.00 <sup>E</sup>
6	<a href="#">Berry Plastics Corp.</a> Evansville, IN	<b>Ira Boots</b> CEO & President	754.00
7	<a href="#">Newell Rubbermaid Inc.</a> (P) Atlanta, GA	<b>Joseph Galli</b> CEO	720.00 <sup>E</sup>
8	<a href="#">Owens-Illinois Inc.</a> (P) Toledo, OH	<b>Michael McDaniel</b> VP & GM, closures & specialty products	605.00 <sup>E</sup>
9	<a href="#">Nypro Inc.</a> Clinton, MA	<b>Brian Jones</b> CEO	591.20
10	<a href="#">Decoma International Inc.</a> <sup>b</sup> Concord, Ontario	<b>Alan Power</b> CEO & President	573.00
11	<a href="#">Guardian Automotive Corp.</a> Warren, MI	<b>D. James Davis</b> CEO & President	465.00 <sup>E</sup>
12	<a href="#">Illinois Tool Works Inc.</a> (P) Glenview, IL	<b>W. James Farrell</b> Chairman & CEO	425.00 <sup>E</sup>
13	<a href="#">Guide Corp.</a> Pendleton, IN	<b>George Sloan</b> President	400.00 <sup>**</sup>
14	<a href="#">Magna Donnelly Corp.</a> <sup>b</sup> Holland, MI	<b>Carlos Mazzorin</b> Chairman & CEO	385.00 <sup>E</sup>
15	<a href="#">Siegel-Robert Inc.</a> St. Louis, MO	<b>David Adams</b> CEO	371.00
16	<a href="#">Letica Corp.</a> Rochester, MI	<b>Anton Letica</b> President	330.00 <sup>E</sup>
17	<a href="#">Lacks Enterprises Inc.</a> Grand Rapids, MI	<b>Richard Lacks Jr.</b> CEO & President	300.00
17	<a href="#">Meridian Automotive Systems Inc.</a> Dearborn, MI	<b>H. H. Wacaser</b> CEO & President	300.00 <sup>E</sup>
19	<a href="#">Venture</a> Fraser, MI	<b>Michael Alexander</b> CFO & VP	290.00 <sup>E</sup>
20	<a href="#">Key Plastics LLC</a> Northville, MI	<b>Tim Nelson</b> COO & President	280.00

21	<u>Neaton Auto Products Manufacturing Inc.</u> Eaton, OH	<b>Masayuki Furugori</b> President	276.00
22	<u>Trend Technologies Inc.</u> Chino, CA	<b>Earl Payton</b> CEO	270.00 <sup>E</sup>
23	<u>Precise Technology Inc.</u> North Versailles, PA	<b>John Weeks</b> Chairman & CEO	264.00
24	<u>Tyco Plastics &amp; Adhesives Group</u> Princeton, NJ	<b>Terry Sutter</b> President, Tyco Plastics & Adhesives Group	260.00 <sup>E</sup>
25	<u>Cascade Engineering Inc.</u> Grand Rapids, MI	<b>Fred Keller</b> Chairman, CEO & Pres.	250.00
25	<u>Summit Polymers Inc.</u> Portage, MI	<b>James Haas</b> President	250.00 <sup>E</sup>
27	<u>Blackhawk Automotive Plastics Inc.</u> Salem, OH	<b>Clifford Croley</b> CEO & President	240.00
28	<u>Phillips Plastics Corp.</u> Hudson, WI	<b>Robert Cervenka</b> Chairman	208.00
29	<u>North America Packaging Corp.</u> Raleigh, NC	<b>Tom Linton</b> CEO & President	207.00
30	<u>Mack Group Inc.</u> Arlington, VT	<b>Don Kendall</b> CEO & President	202.00
31	<u>Plastic Omnium Auto Exteriors LLC</u> Troy, MI	<b>Victor Schneider</b> Vice President	200.00 <sup>E</sup>
32	<u>Portola Packaging Inc.</u> San Jose, CA	<b>Jack Watts</b> Chairman & CEO	196.00
33	<u>Flex-N-Gate Plastics Group</u> Warren, MI	<b>Shahid Khan</b> President	195.00 <sup>E</sup>
33	<u>Saint-Gobain Calmar Inc.</u> City of Industry, CA	<b>John McKernan</b> CEO & President	195.00 <sup>E</sup>
35	<u>NYX Inc.</u> Livonia, MI	<b>Chain Sandhu</b> CEO	190.00
35	<u>Titan Plastics Group Inc.</u> Portage, MI	<b>Greg Botner</b> CEO	190.00 <sup>E</sup>
37	<u>AptarGroup Inc.</u> <sup>(P)</sup> Crystal Lake, IL	<b>Carl Siebel</b> CEO & President	180.00 <sup>E</sup>
37	<u>Bemis Manufacturing Co.</u> Sheboygan Falls, WI	<b>Peter Bemis</b> Executive VP	180.00 <sup>E</sup>
39	<u>Sterilite Corp.</u> Townsend, MA	<b>David Stone</b> President	175.00 <sup>E</sup>
40	<u>Home Products International Inc.</u> <sup>c</sup> Chicago, IL	<b>Doug Ramsdale</b> CEO	170.00 <sup>E</sup>
41	<u>Miniature Precision Components Inc.</u> Walworth, WI	<b>Jim Brost</b> President	167.00
42	<u>Beach Mold &amp; Tool Inc.</u> New Albany, IN	<b>Doug Battliner</b> President	165.00
42	<u>Ropak Packaging</u> Fullerton, CA	<b>Greg Toft</b> President	165.00 <sup>E</sup>
42	<u>Tupperware Corp.</u> <sup>(P) d</sup> Orlando, FL	<b>R. Glenn Drake</b> Group President, North America	165.00 <sup>E</sup>
45	<u>Moll Industries Inc.</u> <sup>e</sup> Dallas, TX	<b>Ron Embree</b> President	160.00
45	<u>United Plastics Group Inc.</u> Westmont, IL	<b>Richard Harris</b> COO	160.00
47	<u>Plastek Industries Inc.</u> Erie, PA	<b>Joseph Prischak</b> CEO	155.00 <sup>E</sup>
48	<u>Carlisle Engineered Products Inc.</u> <sup>f</sup> Crestline, OH	<b>Kevin Early</b> President	154.00
49	<u>ADAC Plastics Inc.</u> Grand Rapids, MI	<b>Jim Teets</b> COO & President	153.00
50	<u>IPL Inc.</u> <sup>(P)</sup> St. Damien, Quebec	<b>Maurice Beauchamp</b> Dir. of operations	151.60

51	<u>Jones Plastic &amp; Engineering Co. LLC</u> Louisville, KY	<b>Craig Jones</b> CEO	145.10
52	<u>Tech Group Inc.</u> Scottsdale, AZ	<b>Harold Faig</b> CEO & President	145.00
52	<u>Sarnamotive Blue Water Inc.</u> <sup>9</sup> Marysville, MI	<b>Andrew Ridgway</b> President	145.00 <sup>E</sup>
54	<u>Lamson &amp; Sessions Co.</u> (P) Cleveland, OH	<b>John Schutze</b> CEO & President	129.00
55	<u>ABC Group Inc.</u> Toronto, Ontario	<b>Claude Elgner</b> Executive VP	120.00
55	<u>Solo Cup Co.</u> Highland Park, IL	<b>Anil Shah</b> Sr. VP operations	120.00 <sup>E</sup>
57	<u>Clarion Technologies Inc.</u> (P) Grand Rapids, MI	<b>Bill Beckman</b> President	113.00 <sup>**</sup>
58	<u>Kerr Group Inc.</u> Lancaster, PA	<b>Richard Hofmann</b> CEO & President	110.00 <sup>E</sup>
58	<u>Medegen Medical Products</u> Gallaway, TN	<b>Mark Dorris</b> President	110.00 <sup>E</sup>
60	<u>Applied Tech Products</u> Radnor, PA	<b>Raymond Langton</b> CEO	105.00
61	<u>Victor Plastics Inc.</u> Victor, IA	<b>Michael Tryon</b> CEO & President	102.50
62	<u>Plastic Products Co. Inc.</u> Lindstrom, MN	<b>Marlene Messin</b> President	101.60
63	<u>Atlantis Plastics Molded Products</u> Division <sup>h</sup> Henderson, KY	<b>John Geary</b> VP & GM	100.00
63	<u>Jarden Plastic Solutions</u> <sup>i</sup> Greer, SC	<b>Chuck Villa</b> COO & President	100.00
63	<u>Technimark Inc.</u> Asheboro, NC	<b>Don Wellington</b> President	100.00
63	<u>CatsonicKansei North America Inc.</u> <sup>j</sup> Shelbyville, TN	<b>Russell Wooten</b> Injection molding mgr.	100.00 <sup>E</sup>
67	<u>Continental Plastics Co.</u> Fraser, MI	<b>Anthony Catenacci</b> President	99.00
67	<u>Flambeau Inc.</u> Baraboo, WI	<b>Marc Mason</b> VP manufacturing	99.00
69	<u>Tiercon Industries Inc.</u> Stoney Creek, Ontario	<b>Rick Legate</b> COO & President	98.60
70	<u>Summa Industries</u> (P) Torrance, CA	<b>James Swartwout</b> President	96.00
70	<u>Tessy Plastics Corp.</u> Elbridge, NY	<b>Roland Beck</b> President	96.00
72	<u>Plastican Inc.</u> Leominster, MA	<b>John Clementi</b> President	95.00 <sup>E</sup>
73	<u>Crown Risdon</u> Watertown, CT	<b>Jim Adams</b> VP operations	90.00
73	<u>Nyloncraft Inc.</u> <sup>k</sup> Mishawaka, IN	<b>Jim Krzyzewski</b> President	90.00
73	<u>Andover Industries</u> <sup>a</sup> Troy, MI	<b>Nick Bogdanos</b> COO & President	90.00 <sup>E</sup>
73	<u>Silgan Closures</u> Downers Grove, IL	<b>Glenn Paulson</b> President	90.00 <sup>E</sup>
77	<u>Injectronics Inc.</u> <sup>j</sup> Clinton, MA	<b>Paul Nazzaro</b> President	85.00
77	<u>Leggett &amp; Platt Inc.</u> (P) <sup>m</sup> Carthage, MO	<b>Jim Ukera</b> President, Plastics Group	85.00
77	<u>Engineered Plastic Components</u> <sup>n</sup> Mattawan, MI	<b>Robert Alexander</b> Vice President, Alcoa	85.00 <sup>E</sup>
80	<u>Consolidated Metco Plastic Division</u> Bryson City, NC	<b>Steve Norman</b> VP operations	84.00

81	<u>Toledo Molding &amp; Die Inc.</u> Toledo, OH	<b>Dave Spotts</b> General mfg. manager	81.00
82	<u>Carson Industries LLC</u> Glendora, CA	<b>Richard Gordinier</b> CEO & President	80.00
82	<u>Sonoco Crellin International</u> Chatham, NY	<b>Bob Puschl</b> Division VP	80.00
84	<u>Filtertek Inc.</u> Hebron, IL	<b>Rick Renjilian</b> VP operations	79.00
84	<u>Kyowa America Corp.</u> Costa Mesa, CA	<b>Sumito Furuya</b> President	79.00
86	<u>Mayco Plastics Inc.</u> Sterling Heights, MI	<b>Timothy Hoefer</b> President	78.00
87	<u>Erie Plastics Corp.</u> Corry, PA	<b>Hoop Roche</b> Chairman	77.80
88	<u>Pilkington</u> ° Niles, MI	<b>Doug Wait</b> Plant manager	75.00
88	<u>Thermotech</u> Hopkins, MN	<b>John Bonham</b> CEO & President	75.00
88	<u>Rehau Inc.</u> Leesburg, VA	<b>Oliver Kaestner</b> VP production	75.00 <sup>E</sup>
88	<u>West Pharmaceutical Services Inc.</u> (P) Lionville, PA	<b>Bob Hargesheimer</b> President, Device Group	75.00 <sup>E</sup>
92	<u>U.S. Farathane Corp.</u> Sterling Heights, MI	<b>Andrew Greenlee</b> CEO & President	74.00
92	<u>Wilbert Plastic Services</u> P Harrisburg, NC	<b>Curtis Zamec</b> Chairman, CEO & Pres.	74.00
94	<u>Leon Plastics Inc.</u> Grand Rapids, MI	<b>Tom Pykosz</b> President	72.50
95	<u>GI Plastek</u> Newburyport, MA	<b>Randy Herman</b> President	71.20
96	<u>Jet Plastica Industries Inc.</u> Hatfield, PA	<b>S. James Spierer</b> President	71.00 <sup>E</sup>
97	<u>Evco Plastics</u> DeForest, WI	<b>Dale Evans</b> President	68.00
98	<u>Reiss Manufacturing Inc.</u> Englishtown, NJ	<b>Carl Reiss</b> President	66.00
99	<u>Vaupell Inc.</u> ° Seattle, WA	<b>Joe Jahn</b> CEO & President	65.40
100	<u>GW Plastics Inc.</u> Bethel, VT	<b>Brenan Riehl</b> CEO & President	65.30
101	<u>Norseman Plastics Ltd.</u> Rexdale, Ontario	<b>Walter Raghunathan</b> VP operations	65.00 <sup>E</sup>
102	<u>Injex Industries Inc.</u> Hayward, CA	<b>Hermilo Martinez</b> Manufacturing manager	60.00
102	<u>Bericap Inc.</u> Burlington, Ontario	<b>Scott Ambrose</b> COO & President	60.00 <sup>E</sup>
102	<u>Georgia-Pacific Corp.</u> (P) Atlanta, GA	<b>Bob Clark</b> Sr. dir. of operations	60.00 <sup>E</sup>
102	<u>Perlos Inc.</u> Fort Worth, TX	<b>Isto Hantila</b> President	60.00 <sup>E</sup>
106	<u>Pine River Plastics Inc.</u> St. Clair, MI	<b>Tim Erdmann</b> President	56.00
107	<u>Cowan Plastics LLC</u> Providence, RI	<b>William Dessel</b> President	55.00
107	<u>Fawn Industries</u> Timonium, MD	<b>John Franzone</b> CEO	55.00
107	<u>Hoffer Plastics Corp.</u> South Elgin, IL	<b>Robert Hoffer</b> President	55.00
107	<u>U.S. Can Corp.</u> Newnan, GA	<b>Philip Mengel</b> CEO	55.00 <sup>E</sup>
111	<u>Engineered Plastic Products Inc.</u> Ypsilanti, MI	<b>Gerald Edwards</b> CEO	51.00 <sup>E</sup>

112	<u>Donatelle Plastics Inc.</u> New Brighton, MN	<b>Treasa Springett</b> President	50.00 <sup>+</sup>
113	<u>Century Mold Co. Inc.</u> Rochester, NY	<b>Ron Ricotta</b> President	50.00
113	<u>Plastipak Industries Inc.</u> La Prairie, Quebec	<b>Normand Tanguay</b> President	50.00
113	<u>Eimo Americas</u> Vicksburg, MI	<b>Joe O'Brien</b> General Manager	50.00 <sup>E</sup>
113	<u>Huhtamäki Americas</u> DeSoto, KS	<b>Kalle Tanhuanpää</b> Executive VP, Americas	50.00 <sup>E</sup>
117	<u>Arkay Industries Inc.</u> West Chester, OH	<b>Kevin Kuhnash</b> Co-CEO & President	49.20
118	<u>D.A. Inc.</u> Charlestown, IN	<b>Kenji Kanii</b> COO & President	49.00
118	<u>OEM/Erie Inc.</u> Erie, PA	<b>Don Cunningham</b> President	49.00
120	<u>Intec Group Inc.</u> Palatine, IL	<b>Steve Perlman</b> President	46.00
121	<u>Alcan Packaging</u> Chicago, IL	<b>Jerry Rodell</b> VP operations	45.00
121	<u>Rosti Americas</u> Minden, LA	<b>Tommy Neal</b> COO	45.00
121	<u>Industrial Containers Ltd.</u> Toronto, Ontario	<b>Morton Arshinoff</b> President	45.00 <sup>E</sup>
124	<u>UFE Inc.</u> Stillwater, MN	<b>Lelan Jamison</b> General Manager	44.00
125	<u>Port Erie Plastics Inc.</u> Harborcreek, PA	<b>John Johnson</b> President	42.00
125	<u>AMP Industries</u> Harrison Township, MI	<b>Rick Bessette</b> Vice President	42.00 <sup>E</sup>
127	<u>Engineered Products Industries LLC</u> Hazelwood, MO	<b>Ron McGee</b> VP & Dir. tech. services	41.30
128	<u>Millennium Plastics Technologies LLC</u> El Paso, TX	<b>Kris Lovell</b> Dir. sales & marketing	40.00
128	<u>Mold-Rite Plastics Inc.</u> Plattsburg, NY	<b>Mark Goyette</b> Molding manager	40.00 <sup>E</sup>
128	<u>National Molding Corp.</u> Farmingdale, NY	<b>Joseph Anscher</b> President	40.00 <sup>E</sup>
128	<u>Rexam Sussex</u> Sussex, WI	<b>Keith Everson</b> President	40.00 <sup>E</sup>
132	<u>Koller Enterprises Inc.</u> Fenton, MO	<b>A.J. Koller III</b> President	39.00
132	<u>Lenco Inc.-PMC</u> Waverly, NE	<b>Paritosh Chakrabarti</b> CEO & President	39.00
132	<u>ORC Plastics</u> Oneida, NY	<b>Kimball Bradley</b> COO & President, Reunion Industries Inc.	39.00
132	<u>Tricon Industries Inc.</u> Lisle, IL	<b>John Winkler</b> VP internal operations	39.00
136	<u>Dinesol Plastics Inc.</u> Niles, OH	<b>Ken Leonard</b> Vice President	38.00 <sup>E</sup>
137	<u>Spartech Industries</u> Clayton, MO	<b>George Abd</b> CEO & President	37.90
138	<u>Plastech Corp.</u> Rush City, MN	<b>Dennis Frandsen</b> CEO	37.00
139	<u>Alliance Precision Plastics Corp.</u> Rochester, NY	<b>Bradley Scott</b> President	36.00
139	<u>Capsonic Group LLC</u> Elgin, IL	<b>Dale White</b> COO	36.00
141	<u>Easley Custom Plastics Inc.</u> <sup>†</sup> Easley, SC	<b>Steven Olson</b> VP sales & engineering	35.00
141	<u>FM Corp.</u> Rogers, AR	<b>Mike Watts</b> CEO	35.00

141	<u>Lakeside Plastics Ltd.</u> Windsor, Ontario	<b>Glenn Coates</b> President	35.00
141	<u>Mid-South Industries Inc.</u> Annville, KY	<b>Ted Cochis</b> President	35.00
141	<u>Pixley Richards Inc.</u> Plymouth, MA	<b>Ian MacLeod</b> Vice President	35.00
141	<u>Maryland Plastics Inc.</u> Federalsburg, MD	<b>Allen Penrod</b> President	35.00 <sup>E</sup>
147	<u>Engineered Polymers Corp.</u> Mora, MN	<b>Jeff Fackler</b> Vice President	34.00
147	<u>Mar-Bal Inc.</u> Chagrin Falls, OH	<b>Scott Balogh</b> President	34.00
149	<u>Enplas (U.S.A.) Inc.</u> Marietta, GA	<b>Daisuke Yokata</b> President	33.00
149	<u>Progress Plastic Products Inc.</u> Bellevue, OH	<b>Todd Young</b> President	33.00
151	<u>Libralter Plastics Inc.</u> <sup>5</sup> Walled Lake, MI	<b>Alan Barr</b> President	32.10
152	<u>Sur-Flo Plastics &amp; Engineering Inc.</u> Warren, MI	<b>James Marshall</b> CEO	31.00
153	<u>Innatech LLC</u> Rochester, MI	<b>John Palmer</b> Sales & marketing mgr.	30.00 <sup>+</sup>
154	<u>AMA Plastics Inc.</u> Corona, CA	<b>Mark Atchison</b> CEO & President	30.00
154	<u>Hi-Tech Plastics Inc.</u> Cambridge, MD	<b>Douglas Bennett</b> President	30.00
154	<u>Horn Plastics Inc.</u> Whitby, Ontario	<b>Asif Rizvi</b> President	30.00
154	<u>Suburban Plastics Co.</u> Elgin, IL	<b>W.S. Baxter</b> President	30.00
154	<u>C&amp;J Industries Inc.</u> Meadville, PA	<b>Dennis Frampton</b> President	30.00 <sup>E</sup>
154	<u>Webster Plastics Inc.</u> <sup>t</sup> Fairport, NY	<b>Vern DeWitt</b> President	30.00 <sup>E</sup>
160	<u>United Southern Industries Inc.</u> Forest City, NC	<b>Todd Bennett</b> President	28.50
161	<u>Baytech Plastics Inc.</u> Midland, Ontario	<b>Anton Mudde</b> CEO	28.00
161	<u>Fabrik Molded Plastics Inc.</u> McHenry, IL	<b>Keith Wagner</b> General Manager	28.00
161	<u>Graber-Rogg Inc.</u> Cranford, NJ	<b>Geoff Engelstein</b> President	28.00
161	<u>PTI Engineered Plastics Inc.</u> Clinton Township, MI	<b>Kurt Nerva</b> President	28.00
161	<u>Transnav Technologies Inc.</u> New Baltimore, MI	<b>Gerrit Vreeken</b> President	28.00 <sup>**</sup>
161	<u>Industrial Molding Corp.</u> Lubbock, TX	<b>Calvin Leach</b> General Manager	28.00 <sup>E</sup>
167	<u>Black River Plastics</u> Port Huron, MI	<b>Peter Mytryk</b> COO	27.00
168	<u>Majors Plastics Inc.</u> Omaha, NE	<b>Tim McConnell</b> President	26.70
169	<u>Midwest Plastic Components</u> Minneapolis, MN	<b>Peter Thompson</b> President	26.50
170	<u>Engineered Specialty Plastics Inc.</u> Hot Springs, AR	<b>Eric Kirkman</b> CEO & President	26.00
170	<u>May &amp; Scofield Inc.</u> Fowlerville, MI	<b>Rick Scofield</b> President	26.00
172	<u>Carthuplas Inc.</u> Kennebunk, ME	<b>Peter Ciriello</b> CEO & President	25.00
172	<u>Injectron Corp.</u> Plainfield, NJ	<b>Lou Pollak</b> President	25.00

172	<u>Shepherd Products Inc.</u> Brampton, Ontario	<b>T. Breckenridge</b> President	25.00
172	<u>St. Clair Plastics Co.</u> Chesterfield, MI	<b>William Lianos</b> President	25.00
172	<u>Top Seal</u> Boyertown, PA	<b>Fred Bielsecker</b> President	25.00
172	<u>Universal Plastic Mold (UPM) Inc.</u> Baldwin Park, CA	<b>Wayne Oxford</b> CEO	25.00
172	<u>Vincent Industrial Plastics Inc.</u> Henderson, KY	<b>James Vincent</b> CEO & President	25.00
172	<u>Grand Haven Plastics Inc.</u> Grand Haven, MI	<b>Alan Chapel</b> President	25.00 <sup>E</sup>
172	<u>Molded Products Co.</u> Haltom City, TX	<b>John Reichwein Jr.</b> President	25.00 <sup>E</sup>
181	<u>DeRoyal Plastics Group</u> Powell, TN	<b>Andrew Adams</b> Dir. of operations	24.50
182	<u>Innovative Injection Technologies Inc.</u> West Des Moines, IA	<b>Robert Janeczko</b> CEO & President	24.00
182	<u>Ironwood Plastics Inc.</u> Ironwood, MI	<b>Mark Stephens</b> Vice President	24.00
182	<u>Moldamatic Inc.</u> Penn del, PA	<b>Raymond Malenfant</b> President	24.00
182	<u>Seltz Corp.</u> Torrington, CT	<b>Damian Macaluso</b> VP & GM	24.00
182	<u>Trostel SEG Inc.</u> Lake Geneva, WI	<b>Tom Sicane</b> President	24.00
187	<u>Lakeland Tool &amp; Engineering Inc.</u> Anoka, MN	<b>Marty Sweerin</b> Secretary & Treasurer	23.50
188	<u>Schnipke Engraving Co. Inc.</u> Ottoville, OH	<b>Eileen Halter</b> CEO	23.00
188	<u>Specialty Manufacturers Inc.</u> Indianapolis, IN	<b>John Lucas</b> CEO	23.00
188	<u>Craftech Corp.</u> Anaheim, CA	<b>Alfredo Bonetto</b> Sr. Vice President	23.00 <sup>E</sup>
191	<u>Agapé Plastics Inc.</u> Grand Rapids, MI	<b>Cynthia Alt</b> Chairman	22.90
192	<u>Schefenacker Vision Systems USA Inc.</u> Marysville, MI	<b>Troy Buset</b> Molding manager	22.30
193	<u>PTA Corp.</u> Oxford, CT	<b>Ray Seeley</b> CEO	22.00
193	<u>QMR Plastics</u> River Falls, WI	<b>Aron Yngve</b> Executive VP	22.00
193	<u>Falcon Plastics Inc.</u> Brookings, SD	<b>Jay Bender</b> COO	22.00 <sup>E</sup>
196	<u>Stull Technologies</u> Somerset, NJ	<b>Gene Stull Sr.</b> CEO & President	21.90
197	<u>ATC Lighting &amp; Plastics Inc.</u> Geneva, OH	<b>Dan Weber</b> Plant manager	21.10
198	<u>Juno Inc.</u> Anoka, MN	<b>Archie Olson</b> President	21.00
198	<u>Norco Injection Molding Inc.</u> Chino, CA	<b>Jack Williams</b> CEO	21.00 <sup>E</sup>
200	<u>Donnelly Custom Manufacturing Co.</u> Alexandria, MN	<b>Sam Wagner</b> Dir. of advanced manufacturing	20.00
200	<u>Leaktite Corp.</u> Leominster, MA	<b>Rodney Sparrow</b> President	20.00
200	<u>Sanmina-SCI Enclosure Systems</u> Turtle Lake, WI	<b>Phil Sorensen</b> Operations manager	20.00
200	<u>Tom Smith Industries Inc.</u> Clayton, OH	<b>Steve Good</b> President	20.00
200	<u>Traex</u> Dane, WI	<b>Steve Boeder</b> Plant manager	20.00

200	<u>Edge Plastics Inc.</u> Mansfield, OH	<b>Perry Brady</b> Plant manager	20.00 <sup>E</sup>
200	<u>MacDonald's Industrial Products</u> Grand Rapids, MI	<b>Rod Adams</b> President	20.00 <sup>E</sup>
200	<u>Norland Plastics Co.</u> Haysville, KS	<b>Dennis Velliquette</b> Plant manager	20.00 <sup>E</sup>
208	<u>Plaspros Inc.</u> McHenry, IL	<b>Norman Dusenberry</b> Vice President	19.90
209	<u>Sajar Plastics Inc.</u> Middlefield, OH	<b>Joseph Bergen</b> CEO	19.80
210	<u>Master Molded Products Corp.</u> Elgin, IL	<b>James Weinhart</b> President	19.50
211	<u>LMT-Mercer Group Inc.</u> <sup>u</sup> Lawrenceville, NJ	<b>Tony Lesenskyj</b> President	18.50
212	<u>Wise-Hamlin Plastics Inc.</u> St. Charles, IL	<b>Fred Wise</b> President	18.20
213	<u>All Service Plastic Molding Inc.</u> Dayton, OH	<b>Joe Kavalauskas</b> Vice President	18.00
213	<u>Chemtech Plastics Inc.</u> Elgin, IL	<b>Ragnar Korthase</b> President	18.00
213	<u>Makray Manufacturing Inc.</u> Norridge, IL	<b>Michael Quig</b> President	18.00
213	<u>Avail Medical Products Inc.</u> San Diego, CA	<b>R. Scott White</b> VP operations	18.00 <sup>E</sup>
213	<u>Carolina Precision Plastics</u> Asheboro, NC	<b>Brian Tauber</b> President	18.00 <sup>E</sup>
213	<u>Volk Enterprises Inc.</u> Turlock, CA	<b>Steve Volk</b> VP operations	18.00 <sup>E</sup>
219	<u>Ferriot Inc.</u> Akron, OH	<b>Craig Ferriot</b> Dir. molding & finishing div.	17.25
220	<u>Adkey Inc.</u> Goodland, IN	<b>Gary Rheude</b> President	17.00
220	<u>Precision Southeast Inc.</u> Myrtle Beach, SC	<b>S. Richard Averette</b> President	17.00
222	<u>Hi-Tech Mold and Tool Inc.</u> Louisville, KY	<b>Gerald Cox</b> President	16.50
222	<u>Circle Plastics Products Inc.</u> Circleville, OH	<b>David Greenlee</b> President	16.50 <sup>E</sup>
224	<u>Action Products Co.</u> Odessa, MO	<b>Bruce Bellington</b> CEO	16.00
224	<u>DeKalb Molded Plastics Co.</u> Butler, IN	<b>Rick Walters</b> VP operations	16.00
224	<u>Schiffmayer Plastics Corp.</u> Algonquin, IL	<b>Karl Schiffmayer</b> President	16.00
227	<u>Decatur Plastic Products Inc.</u> North Vernon, IN	<b>John Kussman</b> President	15.60
228	<u>GSW Building Products</u> Barrie, Ontario	<b>Dennis Nykotiatiou</b> President	15.50 <sup>E</sup>
229	<u>LMR Plastics</u> Greeneville, TN	<b>Bob Leonard</b> President	15.30
230	<u>Captive Plastics Inc.</u> Pliscataway, NJ	<b>Dennis Eckels</b> VP manufacturing	15.00
230	<u>Contour Plastics Inc.</u> Baldwin, WI	<b>Barry Grant</b> President	15.00
230	<u>E-S Plastic Products Inc.</u> Waterford, WI	<b>Peter Keddle</b> President	15.00
230	<u>Engineered Plastic Components Inc.</u> Grinnell, IA	<b>Reza Kargarzadeh</b> President	15.00
230	<u>Kurz-Kasch Inc.</u> Dayton, OH	<b>Chris Eichmann</b> Dir. of sales	15.00
230	<u>Lomont Molding Inc.</u> Mount Pleasant, IA	<b>J.D. Schimmelpfennig</b> President	15.00



230	<u>Plasticraft Mfg. Co. Inc.</u> Albertville, AL	<b>Edwin Ingram</b> President	15.00
230	<u>Venture Plastics Inc.</u> Newton Falls, OH	<b>Steve Trapp</b> VP & GM	15.00
230	<u>Western Plastics</u> Portland, TN	<b>Steven Nichols</b> President & GM	15.00
230	<u>Imperial Plastics Inc. v</u> Lakeville, MN	<b>Norman Oberto</b> President	15.00 <sup>E</sup>
230	<u>N-K Manufacturing Technologies Inc.</u> Grand Rapids, MI	<b>Armen Kassouni</b> Vice President	15.00 <sup>E</sup>
241	<u>Ferguson Production Inc.</u> McPherson, KS	<b>Scott Ferguson Sr.</b> VP operations	14.80
241	<u>Madan Plastics Inc.</u> Cranford, NJ	<b>Michael Madan</b> General Manager	14.80
243	<u>Advent Tool &amp; Mold Inc.</u> Rochester, NY	<b>Ken Desrosiers</b> President	14.50
243	<u>Elgin Molded Plastics Inc.</u> Elgin, IL	<b>Todd Farwell</b> Dir. of operations	14.50
243	<u>Kam Plastics Corp. w</u> Holland, MI	<b>Peter Prouty</b> President	14.50
243	<u>Plasticorp</u> Harbor City, CA	<b>Dennis Mitchell</b> President	14.50
243	<u>Syracuse Plastics LLC</u> Liverpool, NY	<b>Thomas Falcone</b> President	14.50
243	<u>Medway Plastics Corp.</u> Long Beach, CA	<b>Thomas Hutchinson</b> President	14.50 <sup>E</sup>
249	<u>Primera Plastics Inc.</u> Zeeland, MI	<b>Noel Cuellar</b> President	14.40
250	<u>Par 4 Plastics Inc.</u> Marion, KY	<b>Charlie Hicklin</b> VP operations	14.30
251	<u>Palm Plastics Ltd.</u> Morenci, MI	<b>Jeffrey Owen</b> President	14.20
251	<u>Zappa Plastics Inc.</u> Phillipsburg, NJ	<b>Robert Zappa</b> VP & GM	14.20
253	<u>Tribar Manufacturing LLC</u> Whitmore Lake, MI	<b>Robert Bretz</b> President	14.10
254	<u>C-Plastics Corp.</u> Leominster, MA	<b>Gordon Curtis</b> CEO	14.00
254	<u>Fenner Drives</u> Manheim, PA	<b>Erik Nadeau</b> Plant manager	14.00
254	<u>Hilco Technologies</u> Grand Rapids, MI	<b>Dan Taliaferro</b> Vice President	14.00
254	<u>Matrix Inc.</u> East Providence, RI	<b>John Harker</b> President	14.00
254	<u>Molding International &amp; Engineering Inc.</u> Temecula, CA	<b>Gregg Hughes</b> President	14.00
254	<u>Spectrum Plastics Molding</u> Ansonia, CT	<b>Ed Flaherty</b> VP engineering	14.00
254	<u>Akron Porcelain &amp; Plastics Co.</u> Akron, OH	<b>Crawford Smith</b> Plant manager	14.00 <sup>E</sup>
254	<u>D&amp;M Plastics Corp.</u> Burlington, IL	<b>Stephen Motisi</b> President	14.00 <sup>E</sup>
254	<u>Montrose Molders Corp.</u> South Plainfield, NJ	<b>William Wilson</b> President	14.00 <sup>E</sup>
254	<u>Rich Mount Inc.</u> Arden, NC	<b>Yutaka Kiyuu</b> President	14.00 <sup>E</sup>
254	<u>Wright Plastic Products Co. LLC</u> Sheridan, MI	<b>Robert Luce</b> President	14.00 <sup>E</sup>
265	<u>Hansen Plastics Corp.</u> Elgin, IL	<b>David Watermann</b> President	13.50
265	<u>Plasthec Molding Inc.</u> Ontario, CA	<b>John Kimberlin</b> Engineer	13.50

267	<u>E&amp;O Tool &amp; Plastics Inc.</u> Elk River, MN	<b>Tim Osterman</b> CEO & President	13.20
268	<u>Anchor Tool and Plastic Inc.</u> Minneapolis, MN	<b>Ron Rogers</b> President	13.00
268	<u>Genesis Plastics &amp; Eng. LLC</u> Scottsburg, IN	<b>James Gladden</b> CEO & President	13.00
268	<u>Multi-Plastics Inc.</u> Saegertown, PA	<b>Charles Johnston</b> Operations manager	13.00
268	<u>Polymer Technologies</u> Whitewater, WI	<b>Jeff Keller</b> VP operations & GM	13.00
268	<u>River City Plastic</u> Three Rivers, MI	<b>Howard Ross</b> President	13.00
268	<u>True Precision Plastics LLC</u> <sup>x</sup> Lancaster, PA	<b>Jim Kempf</b> Vice President	13.00
268	<u>King Plastics Inc.</u> Orange, CA	<b>Robert King</b> Vice President	13.00 <sup>E</sup>
268	<u>Plastronics Plus Inc.</u> <sup>y</sup> East Troy, WI	<b>Jay Horan</b> Divisional Vice President	13.00 <sup>E</sup>
276	<u>Topcraft Precision Molders Inc.</u> Warminster, PA	<b>Oscar Musitano</b> President	12.50
276	<u>S&amp;W Plastics LLC</u> Eden Prairie, MN	<b>Dave Presler</b> COO	12.50 <sup>E</sup>
278	<u>Accellent Inc.</u> <sup>z</sup> Upland, CA	<b>Rocky Morrison</b> Dir. of operations	12.00
278	<u>Acrotech Southwest Inc.</u> Kerrville, TX	<b>Thomas Houdeshell</b> VP & GM	12.00
278	<u>Custom Plastics International Ltd.</u> Cobourg, Ontario	<b>Peter Harrison</b> President	12.00
278	<u>Pereles Bros. Inc.</u> Milwaukee, WI	<b>Ted Muccio</b> President	12.00
278	<u>Polycel Structural Foam Inc.</u> Somerville, NJ	<b>Ayman Sawaged</b> Dir. of operations	12.00
278	<u>Syntec Technologies Inc.</u> Pavilion, NY	<b>Paul Tolley</b> President	12.00
278	<u>Altek Inc.</u> Liberty Lake, WA	<b>Mike Marzetta</b> President	12.00 <sup>E</sup>
278	<u>Artistic Plastics Inc.</u> Anaheim, CA	<b>Diane Mixson</b> President	12.00 <sup>E</sup>
278	<u>ASK Lehigh Valley</u> Philadelphia, PA	<b>Andy Vartanian</b> President	12.00 <sup>E</sup>
278	<u>Eclipse Mold Inc.</u> Clinton Township, MI	<b>Steve Craprotta</b> VP & GM	12.00 <sup>E</sup>
278	<u>Hampson Corp.</u> <sup>a</sup> North Ridgeville, OH	<b>Doug Johnson</b> VP & COO	12.00 <sup>E</sup>
278	<u>Precision Plastics Inc.</u> Columbia City, IN	<b>Ronald Richey</b> CEO & President	12.00 <sup>E</sup>
278	<u>South Bend Plastics Inc.</u> Mishawaka, IN	<b>Austin Drinkall</b> CEO	12.00 <sup>E</sup>
291	<u>Silvertech Enterprises LLC</u> Yorktown, NY	<b>Matt Kness</b> General Manager	11.50
292	<u>Steinwall Inc.</u> Coon Rapids, MN	<b>Maureen Steinwall</b> President	11.30
293	<u>Hicks Plastics Co. Inc.</u> Macomb Township, MI	<b>Tim Hicks</b> General Manager	11.00
293	<u>Pioneer Plastics Inc.</u> Dixon, KY	<b>Edward Knapp</b> President	11.00
293	<u>Protomold Co. Inc.</u> Maple Plain, MN	<b>Bradley Cleveland</b> CEO & President	11.00
293	<u>Sun Plastics Inc.</u> Elk Grove Village, IL	<b>George Gemberling</b> President & owner	11.00
293	<u>Accent Plastics Inc.</u> Corona, CA	<b>Thomas Pridonoff</b> President	11.00 <sup>E</sup>

293	<u>Anderson Technologies</u> Grand Haven, MI	<b>Glenn Anderson</b> President	11.00 <sup>E</sup>
293	<u>Bardot Plastics Inc.</u> Easton, PA	<b>J. Lee Boucher</b> President	11.00 <sup>E</sup>
300	<u>Viking Plastics Inc.</u> Corry, PA	<b>Kelly Goodsel</b> CEO & President	10.70
301	<u>Hi-Tech Mold &amp; Tool Inc.</u> Pittsfield, MA	<b>Wm Kristensen Sr.</b> President	10.50
301	<u>Tri-Star Plastics Inc.</u> Anaheim, CA	<b>Keith Johnson</b> Vice President	10.50
303	<u>Pierson Industries Inc.</u> Denville, NJ	<b>Theodore Pierson</b> President	10.40
304	<u>Plastic Solutions Inc.</u> South Bend, IN	<b>Robert Tennyson</b> CEO	10.30
304	<u>Stoesser-Gordon Plastics</u> Santa Rosa, CA	<b>Bob Stoesser</b> President	10.30
306	<u>G&amp;F Industries Inc.</u> Sturbridge, MA	<b>John Argitis</b> President	10.10
306	<u>Hamelin Enterprises</u> Boucherville, Quebec	<b>Nadine Hamelin</b> President	10.10
306	<u>Polymer Conversions Inc.</u> Orchard Park, NY	<b>Jack Bertsch</b> President	10.10
306	<u>RTC Inc.</u> West St. Paul, MN	<b>Mark Nelson</b> President	10.10
310	<u>Autolign Manufacturing Group Inc.</u> Milan, MI	<b>Robert Bedrosian</b> CEO & President	10.00 <sup>+</sup>
310	<u>Design Plastics Inc.</u> Omaha, NE	<b>John Nepper Jr.</b> President	10.00 <sup>+</sup>
312	<u>Blue Star Plastics Inc.</u> Lexington, KY	<b>Roger Storch</b> General Manager	10.00
312	<u>Cary Products Co. Inc.</u> Hutchins, TX	<b>Frank Haas</b> President	10.00
312	<u>Century Container Corp.</u> New Waterford, OH	<b>Don Brothers</b> Chairman & CEO	10.00
312	<u>Engineered Plastics Corp.</u> Menomonee Falls, WI	<b>Deb Bristol</b> President	10.00
312	<u>Pent Custom Molding</u> <sup>b</sup> Avilla, IN	<b>Rick Wlęcinski</b> General Manager	10.00
312	<u>Plastocon Inc.</u> Oconomowoc, WI	<b>Jim Nurmi</b> President	10.00
312	<u>Quintex Corp.</u> Nampa, ID	<b>Dorothea Christiansen</b> President	10.00
312	<u>Spir-it Inc.</u> Andover, MA	<b>Robert Morissette</b> VP operations	10.00
312	<u>Stratford Plastic Components Corp.</u> Stratford, Ontario	<b>Gil Kilmer</b> VP sales & marketing	10.00
312	<u>Tailor Made Products</u> Elroy, WI	<b>John Wilde</b> CEO & President	10.00
312	<u>Thogus Products Co.</u> Avon Lake, OH	<b>Kathleen Hlavin</b> President	10.00
312	<u>Van Der Woude Plastics LLC</u> Milan, IL	<b>Brig Vanderwoude</b> President	10.00
312	<u>Bruce Plastics Inc.</u> Pittsburgh, PA	<b>Russell Smith</b> President	10.00 <sup>E</sup>
312	<u>Centech Plastics Inc.</u> Elk Grove Village, IL	<b>Peter Varhegyi</b> CEO & President	10.00 <sup>E</sup>
312	<u>Clairson Plastics</u> Ocala, FL	<b>Steve Nilson</b> Dir. of operations & engineering	10.00 <sup>E</sup>
312	<u>Classic Molding Co. Inc.</u> Schiller Park, IL	<b>Larry Caldron</b> President	10.00 <sup>E</sup>
312	<u>Fox Valley Molding Inc.</u> Plano, IL	<b>Don Haag</b> President	10.00 <sup>E</sup>

312	<u>Infinity Molding &amp; Assembly Inc.</u> Mount Vernon, IN	N.A.	10.00 <sup>E</sup>
312	<u>Miner Elastomer Products Corp.</u> St. Charles, IL	<b>Ed Hahn</b> Dir. of manufacturing	10.00 <sup>E</sup>
312	<u>Oregon Precision Industries Inc. dba PakTech</u> Eugene, OR	<b>Jim Borg</b> President	10.00 <sup>E</sup>
312	<u>Performance Engineered Products Inc.</u> Pomona, CA	<b>Carl Dispenziere</b> President	10.00 <sup>E</sup>
312	<u>Pliant Plastics Corp.</u> Muskegon, MI	<b>Bill Klungle</b> General Manager	10.00 <sup>E</sup>
312	<u>Sipco Molding Technologies</u> Meadville, PA	<b>Chris Adams</b> Operations manager	10.00 <sup>E</sup>
312	<u>Summit Plastic Molding</u> Shelby Township, MI	<b>Raymond Kalinowski</b> CEO	10.00 <sup>E</sup>
336	<u>World Class Plastics Inc.</u> Russells Point, OH	<b>Steve Buchenroth</b> President	9.98
337	<u>Accurate Molded Plastics Inc.</u> Coeur d'Alene, ID	<b>Dale Meyer</b> President	9.80
338	<u>Plastic Masters Inc.</u> New Buffalo, MI	<b>Robert Orlaske</b> CFO	9.50 <sup>E</sup>
339	<u>Midtec Inc. of America</u> McPherson, KS	<b>Tom Burnholz</b> Dir. of manufacturing	9.20
340	<u>Peerless Injection Molding LLC</u> Gardena, CA	<b>Scott Taylor</b> President	9.10
341	<u>Currier Plastics Inc.</u> Auburn, NY	<b>John Currier</b> President	9.00
341	<u>Guttenberg Industries Inc.</u> Guttenberg, IA	<b>Don Overman</b> Vice President	9.00
341	<u>Ironwood Industries Inc.</u> Libertyville, IL	<b>Robert Grala</b> President	9.00
341	<u>Nordon Inc.</u> Rochester, NY	<b>Terry Donovan</b> CEO & President	9.00
341	<u>Perry Machine &amp; Die Inc.</u> Perry, MO	<b>David Berry</b> Vice President	9.00
341	<u>Plastic Molding Technology Inc.</u> El Paso, TX	<b>Charles Sholtis</b> CEO	9.00
341	<u>Putnam Precision Molding Inc.</u> Putnam, CT	<b>Jeanne Zesut</b> VP & GM	9.00
341	<u>Precimold Inc.</u> Candiac, Quebec	<b>Gunter Weiss</b> President	9.00**
341	<u>EPI Advanced LLC</u> <sup>c</sup> Sherman, MS	<b>Dan Lewis</b> General Manager	9.00 <sup>E</sup>
341	<u>Flair Molded Plastics Inc.</u> Evansville, IN	<b>Jim Peters</b> President	9.00 <sup>E</sup>
341	<u>Integrity Plastics Inc.</u> Lakeview, OH	<b>D. Andrew Templeton</b> President	9.00 <sup>E</sup>
341	<u>Polyfab Corp.</u> Sheboygan, WI	<b>Richard Gill</b> CEO	9.00 <sup>E</sup>
353	<u>Polienvasas SA de CV</u> Garcia, Nuevo León	<b>Ismael Gomez</b> President	8.90
354	<u>Amtec Molded Products</u> Rockford, IL	<b>William Pizzo</b> VP operations	8.50
354	<u>Harbor Plastics Manufacturing Co.</u> Richmond, CA	<b>Jon Lawlis</b> President	8.50
354	<u>Interplex Plastics Inc.</u> Lexington, KY	<b>Stanley Isenstein</b> President	8.50
354	<u>TKA Plastics Corp.</u> Winchester, TN	<b>Michael L. Cherry Sr.</b> CEO & President	8.50
354	<u>ELS Plastics Corp.</u> Oldcastle, Ontario	<b>Ronald Stammersky</b> President	8.50 <sup>E</sup>
354	<u>Infinity Plastics LLC</u> Ventura, CA	<b>John Van Bosch</b> Chairman & CEO	8.50 <sup>E</sup>

360	<u>21st Century Plastics Corp.</u> Pottersville, MI	<b>Greg Dobie</b> VP operations	8.40
360	<u>ABA-PGT Inc.</u> Manchester, CT	<b>Samuel Pierson</b> President	8.40
360	<u>Injection Technology Corp.</u> Arden, NC	<b>Carl Morris</b> President	8.40
363	<u>Van Norman Molding LLC</u> Bridgeview, IL	<b>Rich Andre</b> Sales manager	8.30
364	<u>Modern Plastics Corp.</u> Benton Harbor, MI	<b>John Eberhardt</b> Dir. of manufacturing	8.20
365	<u>Acromatic Plastics Inc.</u> Leominster, MA	<b>Peter Crisci</b> President	8.00
365	<u>Custom Plastics Inc.</u> Elk Grove Village, IL	N.A.	8.00
365	<u>East Coast Plastics Inc.</u> Fort Lauderdale, FL	<b>R.D. Trank</b> President	8.00
365	<u>Harding Manufacturing Corp.</u> Rome, NY	<b>Henry W. Harding Jr.</b> President	8.00
365	<u>Techno Plastics Industries Inc.</u> Añasco, PR	<b>Roberto Tous</b> President & GM	8.00
365	<u>TNT Plastic Molding Inc.</u> Anaheim, CA	<b>Murray Anderson</b> Dir. sales & marketing	8.00
365	<u>W-L Molding Co.</u> Portage, MI	<b>Al McKeown</b> President	8.00
365	<u>Wilden Plastics (USA) LP</u> Peachtree City, GA	<b>Heinz Dierselhuis</b> Dir. of operations	8.00
365	<u>Integrity Plastics Inc.</u> Denver, PA	<b>Michael Frey</b> VP operations	8.00**
365	<u>Grant Plastics Inc.</u> Brookline, NH	<b>Bruce Curtis</b> Plant manager	8.00 <sup>E</sup>
365	<u>Preproduction Plastics Inc.</u> Corona, CA	<b>Koby Loosen</b> Vice President	8.00 <sup>E</sup>
365	<u>Rockford Molded Products Inc.</u> Loves Park, IL	<b>Wayne Rasher</b> General Manager	8.00 <sup>E</sup>
365	<u>Wright Engineered Plastics Inc.</u> Santa Rosa, CA	<b>Barbara Roberts</b> President	8.00 <sup>E</sup>
378	<u>K&amp;B Molded Products Div.</u> Brookville, OH	<b>H.E. Kuhns</b> President	7.90
379	<u>B&amp;B Molders LLC</u> Mishawaka, IN	<b>Britt Murphey</b> President & owner	7.80
379	<u>Caprock Manufacturing Inc.</u> Lubbock, TX	<b>Mike Edwards</b> Vice President	7.80
381	<u>Precision Custom Products Inc.</u> DeGraff, OH	<b>J. Greg Best</b> President	7.67
382	<u>Crescent Industries Inc.</u> New Freedom, PA	<b>Eric Paules</b> Operations manager	7.50
382	<u>Distinctive Plastics Inc.</u> Vista, CA	<b>Tim Cumutt</b> President	7.50
382	<u>InnoPlas Corp.</u> Kenton, OH	<b>Keith Kinnear</b> President	7.50
382	<u>Molding Corp. of America</u> Pacoima, CA	<b>Miguel Barba</b> Molding manager	7.50
382	<u>Deimling/Jeliho Plastics Inc.</u> Amelia, OH	<b>William Deimling</b> CEO & President	7.50 <sup>E</sup>
387	<u>Imperial Custom Molding Inc. dba ICM Plastics</u> Rogers, MN	<b>Robert King</b> President	7.40
388	<u>Wadal Plastics Inc.</u> Medford, WI	<b>Robert Lange</b> CEO & President	7.30
389	<u>EPP Team Inc. dba Empire Precision Plastics</u> Rochester, NY	<b>Neal Eill</b> President	7.10
390	<u>Acorn-Gencon Plastics LLC<sup>d</sup></u>	<b>Jeff Wyche</b>	7.00

	Chino, CA	President	
390	<u>Alliance-Carolina</u> Arden, NC	<b>George Lewis</b> President	7.00
390	<u>Automation Plastics Corp.</u> Aurora, OH	<b>Harry Smith</b> President	7.00
390	<u>Bright Plastics</u> Greensboro, NC	<b>Joe Vest</b> VP manufacturing	7.00
390	<u>Caroba Plastics Inc.</u> Englewood, CO	<b>Barry Hart</b> President	7.00
390	<u>Engineering Industries Inc.</u> Verona, WI	<b>Dean Vandenberg</b> President	7.00
390	<u>Global Plastics Inc.</u> Indianapolis, IN	<b>J.R. Spitznogle</b> President	7.00
390	<u>Nescor Plastics Corp.</u> Mesopotamia, OH	<b>Darrell McNair</b> President	7.00
390	<u>Rolco Inc.</u> Kasota, MN	<b>Chip Greene</b> VP operations	7.00
390	<u>Tech NH Inc.</u> Merrimack, NH	<b>Greg Gardner</b> General Manager	7.00
390	<u>Accutec Systems Inc.</u> Eik Grove Village, IL	<b>Larry Sternal</b> VP manufacturing	7.00 <sup>E</sup>
390	<u>DLH Industries Inc.</u> Canton, OH	<b>Isaac Kirbawy</b> Process engineer	7.00 <sup>E</sup>
390	<u>InserTech International Inc.</u> Cary, IL	<b>David Butt</b> President	7.00 <sup>E</sup>
390	<u>Mastercraft Cos.</u> Phoenix, AZ	<b>Arie Rawlings</b> CEO & President	7.00 <sup>E</sup>
390	<u>Motor City Plastics Co. Inc.</u> Dundee, MI	<b>Keith Ruby</b> President	7.00 <sup>E</sup>
390	<u>Polymer Engineered Products Inc.</u> Rochester, NY	<b>Neal Onderdonk</b> President	7.00 <sup>E</sup>
406	<u>Endura Plastics Inc.</u> Kirtland, OH	<b>Mark Dillillo</b> President	6.90
407	<u>Xten Industries LLC</u> Kenosha, WI	<b>William Renick</b> Exec. VP operations	6.85
408	<u>All-Plastics Molding</u> Addison, TX	<b>Larry Byrd</b> President	6.80
409	<u>Franklin Plastics</u> Franklin, IN	<b>Tom Murray</b> Operations manager	6.70
409	<u>Octex Corp.</u> Sarasota, FL	<b>John Weaver</b> Secretary & Treasurer	6.70
411	<u>Kruger Plastic Products</u> Bridgman, MI	<b>Patrick Brandstatter</b> Vice President	6.60
412	<u>Boardman Molded Products Inc.</u> Youngstown, OH	<b>Ronald Kessler</b> CEO & President	6.50
412	<u>HTI Plastics</u> Lincoln, NE	<b>Paul Almburg</b> President	6.50
412	<u>IntegraTech Plastics</u> Hudson, MA	<b>Richard McKenney</b> President	6.50 <sup>E</sup>
412	<u>Plastic Technology Group Inc.</u> Santa Ana, CA	<b>Greg Davis</b> Plant manager	6.50 <sup>E</sup>
416	<u>Brent River Corp.</u> Hillsborough, NJ	<b>Thomas Dolan</b> President	6.45
417	<u>Diversified Manufacturing Inc.</u> Pearl, MS	<b>Sreemukh Sanne</b> President	6.40
418	<u>Res-Tech Corp.</u> Clinton, MA	<b>John Schmidt</b> President	6.30
419	<u>Highland Injection Molding Inc.</u> Salamanca, NY	<b>Jerry Collins</b> President	6.20
419	<u>Stellar Plastics Corp.</u> St. Charles, IL	<b>G. Freimuth</b> President	6.20
419	<u>Hillsman Modular Molding Inc.</u> Titusville, FL	<b>Rodney Hillsman</b> CEO	6.20 <sup>E</sup>

422	<u>Hi-Tech Molding &amp; Tooling</u> Anderson, SC	<b>Tom Beddoe</b> President	6.10
422	<u>M.C. Tietz Plastics Inc.</u> Elgin, IL	<b>Michael Tietz</b> President	6.10
424	<u>Ven-Tel Plastics Corp.</u> Largo, FL	<b>Edward Venner</b> CEO & President	6.00*
425	<u>CIMA Plastics Group</u> Twinsburg, OH	<b>James Stewart</b> President	6.00
425	<u>Eptech Corp.</u> Mount Laurel, NJ	<b>Chris Rapacki</b> Vice President	6.00
425	<u>Humphrey Line Inc.</u> <sup>e</sup> Milwaukie, OR	<b>Melvin Ellis</b> President	6.00
425	<u>Industrial Molded Products Co. Inc.</u> Palatine, IL	<b>Lee Benson</b> President	6.00
425	<u>Plastics Molding Co.</u> St. Louis, MO	<b>Ron Strauser</b> President	6.00
425	<u>Polycore Optical USA</u> Reno, NV	<b>Phil Miller</b> Production manager	6.00
425	<u>Resistance Technology Inc.</u> Arden Hills, MN	N.A.	6.00
425	<u>EuroPlast Ltd.</u> Endeavor, WI	<b>Harald Zacharias</b> President	6.00 <sup>E</sup>
425	<u>P&amp;P Industries Inc.</u> Morrison, IL	<b>Anthony Nardi</b> VP operations	6.00 <sup>E</sup>
425	<u>Vanguard Plastics Corp.</u> Southington, CT	<b>Lawrence Budnick Jr.</b> CEO	6.00 <sup>E</sup>
435	<u>Dyna-Plast Inc.</u> Ramsey, MN	<b>Dave Kalina</b> CEO	5.90
436	<u>Advantage Manufacturing Corp.</u> Friendship, TN	<b>Wanda Rea</b> President	5.80
437	<u>Elite Plastic Products Inc.</u> Shelby Township, MI	<b>Robert Mandeville</b> President	5.60
437	<u>Microdyne Plastics Inc.</u> Ontario, CA	<b>Ronald Brown</b> President	5.60
437	<u>Part Inc.</u> Clover, SC	<b>Dennis Denton</b> President	5.60
437	<u>Veriplas Containers Inc.</u> Little Rock, AR	<b>Thomas McCain</b> President	5.60
441	<u>Micron Molding Inc.</u> Bloomington, MN	<b>C.W. Johnson</b> Co-President	5.50
441	<u>Plastics Plus Technology Inc.</u> Ontario, CA	<b>Kathy Bodor</b> President	5.50
441	<u>S&amp;L Plastics Inc.</u> Nazareth, PA	<b>John Bungert</b> President	5.50
441	<u>Westmoreland Plastics Co.</u> Latrobe, PA	<b>Fred Crocker</b> President	5.50
441	<u>Hy-Ten Plastics Inc.</u> Milford, NH	<b>Craig Heinselman</b> General Manager	5.50 <sup>E</sup>
441	<u>Knightsbridge Plastics Inc.</u> Fremont, CA	<b>David Platt</b> President	5.50 <sup>E</sup>
447	<u>Blue Ridge Industries Inc.</u> Winchester, VA	<b>Mary Sarie</b> President	5.40
448	<u>Am Pro Custom Molding</u> Leeds, AL	<b>Malcolm Kidd</b> General Manager	5.20
448	<u>Precision Plastic &amp; Die Co.</u> Ithaca, MI	<b>George Bailey</b> Vice President	5.20
450	<u>A&amp;E Plastics Inc.</u> Elgin, IL	<b>John Vinka</b> Vice President	5.00
450	<u>Alabama Plastics Inc.</u> Birmingham, AL	<b>Perry Greer</b> General Manager	5.00
450	<u>Hamilton Machine &amp; Mold Inc.</u> Holland, MI	<b>Tim Locke</b> Engineering manager	5.00

450	<u>Industrial Tool &amp; Plastics Inc.</u> St. Croix Falls, WI	<b>Neil Johnson</b> President	5.00
450	<u>Plastopan Industries Inc.</u> Los Angeles, CA	<b>Ronald Miller</b> Vice President	5.00
450	<u>Roma Tool &amp; Plastics Inc.</u> Almena, WI	<b>Milo Hennemann</b> President	5.00
450	<u>Sportsmen's Plastics Inc.</u> Leominster, MA	<b>Hank Lisciotti</b> Vice President	5.00
450	<u>Terhorst Manufacturing Inc.</u> Minot, ND	<b>Ron Martin</b> Molding supervisor	5.00
450	<u>Wonder Molded Products Inc.</u> Crystal Lake, IL	<b>Fred Dickman</b> President	5.00
450	<u>Northeast Mold &amp; Plastics Inc.</u> Glastonbury, CT	<b>Ron Bodeau</b> Production manager	5.00**
450	<u>Luckmarr Plastics Division</u> Sterling Heights, MI	<b>Marco Pierobon</b> Vice President	5.00 <sup>E</sup>
450	<u>Merit Precision Moulding Ltd.</u> Peterborough, Ontario	<b>Tim Barrie</b> President & GM	5.00 <sup>E</sup>
450	<u>Olan Plastics Inc.</u> Canal Winchester, OH	<b>Olan Long</b> CEO	5.00 <sup>E</sup>
450	<u>Palm Beach Precision Molding Co.</u> Riviera Beach, FL	<b>Warren Avis</b> President	5.00 <sup>E</sup>
450	<u>Prism Plastics Inc.</u> New Richmond, WI	<b>Bill Johnson</b> Sales manager	5.00 <sup>E</sup>
450	<u>Tally Ho Plastics Inc.</u> Jacksonville, TX	<b>George Douglas</b> General Manager	5.00 <sup>E</sup>
450	<u>TomKen Tool &amp; Engineering Inc.</u> Muncie, IN	<b>Bruce Carmichael</b> General Manager	5.00 <sup>E</sup>
467	<u>All West Plastics Inc.</u> Antioch, IL	<b>Errol Westergaard</b> President	4.80
468	<u>Advanced Plastics Corp.</u> Warren, MI	<b>Charles Worswick</b> Plant manager	4.60
468	<u>Dimatic Die and Tool Co.</u> Omaha, NE	<b>Scott Drvol</b> President	4.60
468	<u>Johnson Precision Inc.</u> Amherst, NH	<b>Richard St. Onge</b> President	4.60
468	<u>Prolific Plastics</u> Opelika, AL	<b>Jerry Piath</b> President & owner	4.60
472	<u>Affinity Custom Molding Inc.</u> Mendon, MI	<b>Todd Cook</b> Owner & operations mgr.	4.50
472	<u>Bourbon Plastics Inc.</u> Bourbon, IN	<b>Rick Green</b> President	4.50
472	<u>Granite State Plastics Inc.</u> Londonderry, NH	<b>John Callanan</b> President	4.50
472	<u>IEM Plastics Inc.</u> Wixom, MI	<b>Dennis Walters</b> Operations manager	4.50
472	<u>Nicolet Plastics Inc.</u> Mountain, WI	<b>Robert Macintosh</b> VP & COO	4.50
472	<u>Superior Plastics Inc.</u> Plain City, OH	<b>Ed Grimm</b> VP product development	4.50
472	<u>Matrix Tool Inc.</u> Fairview, PA	<b>Dave Lewis Sr.</b> President	4.50*
472	<u>SPI Industries</u> South Bend, IN	<b>John Doster</b> President	4.50 <sup>E</sup>
480	<u>Carl W. Newell Manufacturing Inc.</u> Glendale, CA	<b>Carl Newell</b> President	4.40
481	<u>Champion Injection Molding Inc.</u> Warren, OH	<b>Bo Campbell</b> Plant manager	4.26
482	<u>Dana Molded Products Inc.</u> Arlington Heights, IL	<b>Daniel Hidding</b> CEO	4.21
483	<u>Thermold Corp.</u> Canastota, NY	<b>Ronald Farley</b> President	4.20
484	<u>Sterling Manufacturing Co. Inc.</u>	<b>Dennis Wrzesinski</b>	4.10



	South Lancaster, MA	President	
485	<u>Pittsburgh Plastics Mfg. Inc.</u> Butler, PA	<b>Dave Schmitt</b> Plant manager	4.08
486	<u>LCS Precision Molding Inc.</u> Waterville, MN	<b>Roger Michalski</b> COO	4.00*
487	<u>D&amp;L Tooling &amp; Plastics Inc.</u> Jacksonville, TX	<b>Tommy Dement</b> President	4.00
487	<u>Flex Products</u> Carlstadt, NJ	<b>Chris Smolar</b> Plant manager	4.00
487	<u>Flyte Tool &amp; Die Co.</u> Bridgeport, CT	<b>M. Haddock</b> Operations manager	4.00
487	<u>Proto-Cast LLC</u> Douglassville, PA	<b>Joseph Gizara</b> President	4.00
487	<u>S.K. Plastic Molding Inc.</u> Monroe, WI	<b>Steve Streff</b> President	4.00
487	<u>Cal Am Manufacturing</u> Pacoima, CA	<b>Bias Alcalá</b> Plant manager	4.00 <sup>E</sup>
487	<u>Daystar Products International Inc.</u> Phoenix, AZ	<b>Doug Goodman</b> President	4.00 <sup>E</sup>
487	<u>Premier Molded Plastics Co.</u> Leland, NC	<b>Rick Cauwels</b> Plant manager	4.00 <sup>E</sup>
487	<u>Retlaw Industries Inc.</u> Hartland, WI	<b>Walter Eberhardt</b> President	4.00 <sup>E</sup>
496	<u>Quality Assured Plastics Inc.</u> Lawrence, MI	<b>Annette Crandall</b> President	3.83
497	<u>Custom Plastics Inc.</u> Ontario, CA	<b>Linn Derickson</b> President	3.80
497	<u>Hapco Inc.</u> Baraboo, WI	<b>Larry Skalonz</b> Plant manager	3.80
497	<u>Innovative Plastic Solutions</u> Abingdon, MD	<b>Ray Seward</b> President	3.80
497	<u>Quashnick Tool Corp.</u> Lodi, CA	<b>Duane Saville</b> Plant manager	3.80
497	<u>Performance Plastics Ltd.</u> Cincinnati, OH	<b>Tom Mendel</b> President	3.80 <sup>E</sup>
502	<u>R&amp;D Plastics LLC</u> Hillsboro, OR	<b>Rod Roth</b> President	3.66
503	<u>A&amp;A Global Industries Inc.</u> Cockeysville, MD	<b>Steven Kovens</b> Executive VP	3.60
503	<u>Den Hartog Industries Inc.</u> Hospers, IA	<b>John Den Hartog</b> President	3.60
503	<u>Sunbelt Plastics Inc.</u> Frisco, TX	<b>John Anselmi</b> President & owner	3.60
506	<u>Con-Tech Plastics</u> Brea, CA	<b>Vern Meurer</b> Vice President	3.50
506	<u>DaMar Plastics Inc.</u> San Diego, CA	<b>David Kabbai</b> President	3.50
506	<u>Industrial Plastic Products Inc.</u> Miami Lakes, FL	<b>George Thorne</b> CEO	3.50
506	<u>Plastics One Inc.</u> Roanoke, VA	<b>David Wallenborn</b> CEO & President	3.50
506	<u>Kelly Co. Inc.</u> Clinton, MA	<b>Joe Kelly</b> CEO	3.50 <sup>E</sup>
511	<u>Horvath Co. LLC</u> Scottsdale, AZ	<b>T. Horvath</b> N.A.	3.44
512	<u>B&amp;B Tool and Die Co. Inc.</u> Muncie, IN	<b>Dave Fry</b> Molding manager	3.40
513	<u>Sonolite Plastics Corp.</u> Gloucester, MA	<b>Peter Lawrence</b> President	3.30
514	<u>GMB Enterprises Inc.</u> Cumming, GA	<b>Dave Salomone</b> Plant manager	3.20
514	<u>Myco Plastics Inc.</u> Jacksonville, TX	<b>Edward Snider</b> President	3.20

514	<u>Natech Plastics Inc.</u> Ronkonkoma, NY	<b>Thomas Nagler</b> President	3.20
517	<u>Action Mold &amp; Tool Co.</u> Anaheim, CA	<b>Bill Hall</b> CEO	3.10
517	<u>Astar Inc.</u> South Bend, IN	<b>Sidney Moore Jr.</b> CEO	3.10
517	<u>Holzmeier Die &amp; Mold Mfg. Corp.</u> Princeton, IN	<b>Alan Holzmeier</b> President	3.10
517	<u>Mother Lode Plastics</u> Sonora, CA	<b>Mitch Young</b> General Manager	3.10
521	<u>B.M.P. Injection</u> Riverside, CA	<b>Larry Harden</b> President	3.00
521	<u>Dimension Molding Corp.</u> Addison, IL	<b>Mike Stiglianese</b> President	3.00
521	<u>Fram Trak Industries Inc.</u> Middlesex, NJ	<b>Al Santelli Jr.</b> Owner	3.00
521	<u>George Ko Industries Inc.</u> Erie, PA	<b>Matt Koket</b> President	3.00
521	<u>Hartlage Manufacturing Inc.</u> Buckner, KY	<b>Tony Hartlage</b> Sales & engineering	3.00
521	<u>Hoffman Manufacturing Inc.</u> Concord, MI	<b>Larry Hoffman</b> President	3.00
521	<u>M.D.R. International Inc.</u> North Miami, FL	<b>Bernard Ghelbendorf</b> President	3.00
521	<u>Shape Global Technology</u> Sanford, ME	<b>Bob Crane</b> Engineering	3.00
521	<u>United Plastic Molders Inc.</u> Jackson, MS	<b>W.C. Hoge Jr.</b> Owner	3.00
521	<u>Custom Service Plastics Inc.</u> Lake Geneva, WI	<b>Minoo Selfoddini</b> President	3.00 <sup>E</sup>
521	<u>Magnus Molding</u> Pittsfield, MA	<b>Dave Pedrotti</b> President	3.00 <sup>E</sup>
521	<u>Molding Services of Illinois Inc.</u> <sup>f</sup> Olney, IL	<b>Anthony King</b> President	3.00 <sup>E</sup>
521	<u>River Valley Plastics Inc.</u> Elkart, IN	<b>Harold McCracken</b> President	3.00 <sup>E</sup>
534	<u>Vision Technical Molding LLC</u> Manchester, CT	<b>Anthony Brodeur</b> President	2.95
535	<u>MPS Plastics</u> Marlborough, CT	<b>David Nickolenko</b> General Manager	2.80
536	<u>Limmco Inc.</u> New Albany, IN	<b>Jeff Mosey</b> Sales manager	2.71
537	<u>Erwin Plastics Inc.</u> Riverside, CA	<b>Shane Erwin</b> Sales manager	2.70
537	<u>Plastech Inc.</u> Corvallis, OR	<b>Michael Hendrickson</b> President & owner	2.70
537	<u>Precision Mold &amp; Tool Inc.</u> Kissimmee, FL	<b>Mark Longbrake</b> Vice President	2.70
537	<u>Mastermolding Inc.</u> Joliet, IL	<b>Raymond Steinhart</b> Vice President	2.70 <sup>E</sup>
541	<u>Accurate Molded Products Inc.</u> Warwick, RI	<b>Howard Devine Sr.</b> President	2.50
541	<u>Kingston Plastics Corp.</u> Skokie, IL	<b>Gabriel Hostalet</b> President	2.50
541	<u>Microphor</u> Willits, CA	<b>Peter Keightley-Pugh</b> Manager, custom division	2.50
541	<u>Styletek Inc.</u> Lowell, MA	<b>Richard Salvo</b> Engineering manager	2.50
541	<u>Tact Plastics Inc.</u> Shelby, NC	<b>Glen Smith</b> President	2.50
541	<u>Woodland Plastics Corp.</u> Addison, IL	<b>Lee Sinderson</b> President	2.50

541	<u>Stelray Plastic Products Inc.</u> Ansonia, CT	<b>Larry Saffran</b> President	2.50 <sup>E</sup>
548	<u>Derby Plastics Ltd.</u> Neenah, WI	<b>Thomas Derby</b> President	2.45
549	<u>Oscoda Plastics Inc.</u> Oscoda, MI	<b>Mark Welles</b> Plant manager	2.40
549	<u>Sapona Plastics LLC</u> Asheboro, NC	<b>Dean Lail</b> President	2.40
551	<u>Hope Industries Inc.</u> <sup>9</sup> Madisonville, TN	<b>John Hourenagle</b> CEO	2.30
551	<u>Southern Plastic &amp; Rubber Co.</u> Ormond Beach, FL	<b>Frank Noce</b> Owner	2.30
551	<u>Techna-Plastics Inc.</u> Lehighton, PA	<b>Steve Barilla</b> President	2.30
551	<u>Apex Plastics &amp; Tooling Inc.</u> Garland, TX	<b>Tom O'Connor</b> President	2.30 <sup>E</sup>
555	<u>Detroit Molded Products Inc.</u> Ira Township, MI	<b>Craig Johnson</b> Operations manager	2.20
555	<u>Nylacarb Corp.</u> Vero Beach, FL	<b>Frank Cooley</b> President	2.20
557	<u>CP Plastics Group Inc.</u> Falconer, NY	<b>Marcus Turner</b> President	2.10
557	<u>GD Components de Mexico SA de CV</u> Jiutepec, Morelos	<b>Marco Castilla</b> Subdirector	2.10
559	<u>Autech Plastics</u> Auburn, NY	<b>Charles Beck</b> President	2.04
560	<u>Quake Industries Inc.</u> Belgrade, MT	<b>Ron Pierzina</b> Vice President	2.00 <sup>+</sup>
561	<u>A&amp;D Plastics Inc.</u> Plymouth, MI	<b>Jerry Jagacki</b> General Manager	2.00
561	<u>High Sierra Plastics</u> Bishop, CA	<b>Robert Wilson</b> Owner	2.00
561	<u>Latin American Industries LLC</u> Grand Rapids, MI	<b>Olivia Benitez</b> President	2.00
561	<u>Micromold Inc.</u> Riverside, CA	<b>Ron Peterson</b> General Manager	2.00
561	<u>Mold Precision Engineering Inc.</u> Simi Valley, CA	<b>Peter Minaskanian</b> President	2.00
561	<u>Noble Plastics Inc.</u> Lafayette, LA	<b>Melissa Rogers</b> President	2.00
561	<u>Plastics Group</u> Lawrenceville, GA	<b>Buzz Brockway</b> Operations manager	2.00
561	<u>Richard Plastics Co.</u> Laurel, MS	<b>David Buck</b> President	2.00
561	<u>Ruco Products Inc.</u> Blue Springs, MO	<b>Brenda Rupert</b> President	2.00
561	<u>Selmax Corp.</u> Selinsgrove, PA	<b>Ken Mease</b> CEO	2.00
561	<u>Sinicon Plastics Inc.</u> Pittsfield, MA	<b>David Allen</b> President	2.00
561	<u>Stellar Plastics Inc.</u> San Marcos, TX	<b>Fred Smith</b> President	2.00
561	<u>Abba Plastics Inc.</u> Yorkville, IL	<b>Scott Haws</b> Owner	2.00 <sup>E</sup>
574	<u>Chenango Valley Technologies Inc.</u> Sherburne, NY	<b>Lloyd Baker</b> CEO	1.90
575	<u>Accu-Tech Plastics</u> Batesville, MS	<b>William Byer</b> President	1.80
575	<u>Honor Plastics</u> Ontario, CA	<b>James Prior</b> President	1.80
575	<u>Poly-Ject Inc.</u> Amherst, NH	<b>Larry Thibeault</b> President	1.80

575	<u>Advanced Molding</u> Ontario, OR	<b>Clair Havens</b> Owner	1.80 <sup>E</sup>
575	<u>Master Molders Inc.</u> Orangeburg, SC	<b>Will Smetana</b> President	1.80 <sup>E</sup>
580	<u>Plas-Tech Molding &amp; Design Inc.</u> Brimfield, IN	<b>Kimm Hunt</b> General Manager	1.77
581	<u>Eclipse Manufacturing Co.</u> Lake Zurich, IL	<b>Robert Hinman</b> President	1.75
581	<u>Edco Industries Inc.</u> Bridgeport, CT	<b>John Szalan</b> President	1.75
581	<u>Wepeco Plastics Inc.</u> Middlefield, CT	<b>Waldo Parmelee</b> President	1.75
584	<u>Ashton Plastic Products Inc.</u> Xenia, OH	<b>Richard Keich</b> President	1.70
584	<u>Master Tool and Mold Inc.</u> York, PA	<b>Frederick Stermer</b> President	1.70
586	<u>G.A.I.M. Engineering</u> Bensenville, IL	<b>Skip Giatt</b> President	1.68
587	<u>Aim Processing Inc.</u> Longmont, CO	<b>Jacqueline Jones</b> President	1.60
587	<u>Ark Molding Inc.</u> Denver, CO	<b>Tim Dailey</b> President	1.60
589	<u>Accurate Injection Molds Inc.</u> Clinton Township, MI	<b>Jim Jarrett</b> President	1.50
589	<u>Basque Plastics Corp.</u> Leominster, MA	<b>Clifford Basque</b> President	1.50
589	<u>Four Process Ltd.</u> Fenton, MO	<b>Mark Fox</b> President	1.50
589	<u>Maloney Plastics Inc.</u> Meadville, PA	<b>Edward Maloney</b> President	1.50
589	<u>One Way Plastics Inc.</u> Edon, OH	<b>Joe Peterfeso</b> President	1.50
589	<u>Pearl Custom Plastic Molding</u> Gwynneville, IN	<b>Ken Grimes</b> Owner	1.50
589	<u>Pikes Peak Plastics Inc.</u> Colorado Springs, CO	<b>Dave Anthony</b> President	1.50
589	<u>Pyramid Plastics Inc.</u> Cleveland, OH	<b>James Newman</b> President	1.50
589	<u>R&amp;D Molders Inc.</u> Austin, TX	<b>Gregory Brown</b> President	1.50
589	<u>Tek Enterprise Inc.</u> Hartselle, AL	<b>Thomas Kerr</b> Vice President	1.50
589	<u>Advanced Engineering &amp; Molding Technology Inc.</u> Riverside, CA	<b>Donald Furness</b> President	1.50 <sup>E</sup>
589	<u>R&amp;D Plastics Inc.</u> Arden, NC	<b>R. Dennis Weaver</b> President	1.50 <sup>E</sup>
601	<u>Better Plastics Inc.</u> Kissimmee, FL	<b>W.A. Messina</b> CEO & President	1.45
601	<u>Precision Molded Plastics</u> Upland, CA	<b>Ted VanVoorhis</b> President	1.45
603	<u>Acutek Inc.</u> Odessa, MO	<b>Terry Stebbins</b> Production manager	1.40
603	<u>Plastic Injection Molders Inc.</u> Fertile, IA	<b>Greg Knopf</b> President	1.40
603	<u>Plastic Model Engineering Inc.</u> Post Falls, ID	<b>Jeff Lange</b> President	1.40
603	<u>Summitt Molding &amp; Engineering Inc.</u> Madisonville, KY	<b>Charles Rothe</b> President & co-owner	1.40
603	<u>Syntech Development &amp; Mfg. Inc.</u> Chino, CA	<b>Bob Hobbs</b> CEO & President	1.40
608	<u>Nortic Inc.</u> Oriskany, NY	<b>Coleman Harding</b> President	1.35

609	<u>American Precision Products</u> Huntsville, AL	<b>Mark Bannister</b> President	1.30
609	<u>Gator Plastics Inc.</u> <sup>h</sup> Miami, FL	<b>James O'Brien</b> President	1.30
611	<u>Wilks Precision Instrument Co. Inc.</u> Union Bridge, MD	<b>Thomas Wilks</b> President	1.27
612	<u>Ayanna Plastics &amp; Engineering Inc.</u> Largo, FL	<b>Scott Redmond</b> General Manager	1.25
612	<u>Venture 1 Division, Gibson County Plastics Inc.</u> Yorkville, TN	<b>Ben Cottrell</b> Marketing	1.25
614	<u>Dyna Tech Corp.</u> Largo, FL	<b>Terry Welsch</b> President	1.20
614	<u>Hoffman Precision Plastics Inc.</u> Blackwood, NJ	<b>Joseph Belville</b> Plant manager	1.20 <sup>E</sup>
616	<u>Mid-America Plastic Co.</u> Forreston, IL	<b>Eric Erdmann</b> President	1.15 <sup>E</sup>
617	<u>Advantage Plastic Products Inc.</u> Manchester, NH	<b>Wayne Froman</b> VP operations	1.10
618	<u>Greenleaf Industries</u> Lenoir City, TN	<b>Earle Segrest</b> CEO & President	1.06
619	<u>All-State Plastics Inc.</u> City of Industry, CA	<b>Patrick Minyard</b> President	1.05
620	<u>Engrave Inc.</u> Lawrenceburg, IN	<b>David Polewski</b> VP manufacturing	1.00
620	<u>Great Plains Plastic Molding LLC</u> Fargo, ND	<b>Joseph Schabel</b> Plant manager	1.00
620	<u>Molded Plastic Components Inc.</u> Woonsocket, RI	<b>Marcel Coutu</b> General Manager	1.00
620	<u>Pro Mold Inc.</u> Riverside, CA	<b>Randal Herr</b> VP & GM	1.00
620	<u>RKC&amp;A Plastics</u> Wyoming, MI	<b>Brian Chambers</b> General Manager	1.00
620	<u>V&amp;S Molding Inc.</u> Longmont, CO	<b>Ben Veltien</b> President	1.00
620	<u>Ventura Precision Molding Inc.</u> Ventura, CA	<b>Richard Sloane</b> President	1.00
620	<u>Decatur Plastics Inc.</u> Decatur, TN	<b>Doug Jackson</b> Vice President	1.00 <sup>E</sup>
620	<u>Tennessee Injection Molding Co. LLC</u> Gallatin, TN	<b>Hayden Black</b> President	1.00 <sup>E</sup>
629	<u>Mato Plastics</u> Saugus, CA	<b>Manfred Toll</b> Owner	0.90
630	<u>Aire Plastics Inc.</u> La Vernia, TX	<b>Tobin Post</b> Plant manager	0.87
631	<u>Precision Molded Products</u> San Antonio, TX	<b>Naum Royberg</b> CEO	0.85
632	<u>Dynamic Molding Inc.</u> Loveland, CO	<b>Rick Haack</b> VP & GM	0.82 <sup>E</sup>
633	<u>Chesapeake Plastics Manufacturing Inc.</u> Lusby, MD	<b>Mark McGrath</b> Co-owner	0.78
634	<u>Aegis Plastics Corp.</u> Deer Park, NY	<b>Tom McNamee</b> President	0.75
634	<u>Boyce Engineering Inc.</u> St. Petersburg, FL	<b>Darryl Crowe</b> General Manager	0.75
636	<u>Demoldco Plastics Inc.</u> Anaheim, CA	<b>Nick Trees</b> President	0.70
636	<u>R.C. Westburg Engineering Inc.</u> Laguna Hills, CA	<b>Ron Westburg</b> President	0.70
636	<u>Sierra Chief</u> Lemoncove, CA	<b>Tom Cairns</b> Owner	0.70
639	<u>Simplomatic Manufacturing Co.</u> Chicago, IL	<b>David Hahn</b> Assistant GM	0.65

640	<u>Anderson Plastics Inc.</u> Girard, PA	<b>Steve Anderson</b> President	0.62
641	<u>Port City Custom Plastics</u> Muskegon, MI	<b>Brenda Adams</b> Plant manager	0.60
642	<u>Jerrico Tool Inc.</u> Alden, NY	<b>Jeremy Peirick</b> Molding manager	0.50
642	<u>Plastics USA Inc.</u> West Melbourne, FL	<b>Jerry Covington</b> President	0.50 <sup>E</sup>
644	<u>HPI Molding</u> Elgin, IL	<b>A.J. Dillard</b> Owner	0.48
645	<u>Wolf Mold Inc.</u> Hayden, ID	<b>Randy Carruthers</b> Executive VP	0.40
646	<u>Rix Products</u> Evansville, IN	<b>Rick Rideout</b> Owner	0.39
647	<u>Q&amp;D Plastics Inc.</u> Forest Grove, OR	<b>Don Slezak</b> President	0.38
648	<u>Robson Co. Inc.</u> Girard, PA	<b>Christopher Robson</b> President	0.30
649	<u>Stacktech Systems California Ltd.</u> <sup>†</sup> Walnut, CA	<b>John Catalano</b> Business manager	0.25
650	<u>Red Cedar Plastics LLC</u> Menomonie, WI	<b>Kelly Kadinger</b> President	0.23
651	<u>Modern Molding Inc.</u> Jupiter, FL	<b>Ted Graham</b> President	0.18
652	<u>WDL Enterprises Inc.</u> Clifton, KS	<b>Wayne Lenhart</b> President	0.16
653	<u>Miteject Inc.</u> Santee, CA	<b>Dick Merritt</b> President	0.15
654	<u>Centennial Molding LLC</u> Hastings, NE	<b>Val Kopke</b> VP operations	0.12
655	<u>Plastics and Concepts of Connecticut Inc.</u> Manchester, CT	<b>John Harris</b> General Manager	0.10

(P)=Publicly Held N.A.=Not available

All information was provided by the companies, except where otherwise indicated.

\* Midpoint of a company-provided range

\*\* Company-provided estimate

<sup>E</sup>Plastics News and industry estimates. These figures were *not* provided by the company.

CURRENCY NOTE: All Canadian sales figures have been converted to U.S. dollars using the average annual exchange rate for the 12 months of each company's fiscal year. For fiscal years that correspond to calendar-year 2004 the following average annual rate was used: C\$1=US\$0.77.

All companies' fiscal years correspond the calendar-year 2004 unless otherwise noted.

- a) Plastech Engineered Products Inc. agreed March 25 to acquire the assets of Andover Industries, which was in Chapter 11 bankruptcy protection.
- b) Decoma International Inc.'s publicly held parent, Magna International Inc., has taken the company private, effective March 6, 2005. Magna plans to combine the Decoma injection molding business with its Magna Donnelly Corp. and operate the firms jointly under the Magna Donnelly name.
- c) Home Products International Inc. was acquired by equity firm Storage Acquisition Co. LLC in November 2004 and taken private.
- d) Tupperware Corp.'s data reflects recent layoffs; the company is continuing to curtail U.S. manufacturing operations.
- e) Moll Industries Inc. acquired Textron Inc.'s InteSys Technologies Inc. unit and Formec SA de CV's Monterrey, Mexico, business, early this year. Also reflected in Moll's listing is its acquisition of Creative Plastic Molders Inc. in May 2004.
- f) Carlisle Cos. Inc. has put its Carlisle Engineered Products Inc. unit up for sale.
- g) Switzerland-based Sarna Polymer Holding Inc. has put its Sarnamotive auto supply group up for sale, including Sarnamotive Blue Water Inc. Also, Sarnamotive Blue Water will close its Lexington, Mich., injection molding site by the end of July.
- h) Atlantis Plastics Molded Products Division's data includes its purchase of LaVanture Plastics in November 2004, which included injection molder Molded Designs Technology Inc.
- i) Jarden Plastic Solutions previously was listed as Unimark Plastics.

- j) CalsonicKansei North America Inc. previously was listed as Kantus Corp. Sales for parent CalsonicKansei Corp. are for the fiscal year ended March 31, 2004.
- k) Nyloncraft Inc.'s listing includes certain assets of Automold of America Inc., which it acquired Oct. 29, 2004.
- l) Injelectronics Inc.'s listing includes its May 2004 purchase of Gilreath Inc.
- m) Leggett & Platt Inc. acquired Canadian injection molders Conestogo Plastics Inc. and Shepherd Products Inc. in December 2004.
- n) Alcoa Inc. signed a letter of intent to fully acquire AFL Automotive from joint venture partner Fujikura Ltd. of Japan. Engineered Plastic Components is part of the AFL auto business.
- o) Pilkington plc's corporate sales are for the fiscal year ended March 31, 2004.
- p) Wilbert Plastic Services previously was listed as Morton Custom Plastics Inc.
- q) Newly listed Vaupell Inc. acquired previously listed SciTech Plastics Group LLC in May 2004.
- r) Easley Custom Plastics Inc. previously was listed as McKechnie Plastic Components, which was bought by equity group CH Industries Inc. in May 2004.
- s) Libralter Plastics Inc.'s data includes the operations of Alpine Plastics Inc. The firms recently were consolidated on the basis of common ownership.
- t) Parker Hannifin Corp. acquired Webster Plastics Inc.'s parent, Acadia Elastomers Corp., in November 2004.
- u) LMT-Mercer Group Inc. data includes certain assets of Hartville Plastics Inc., which LMT acquired in February 2004
- v) Duo Plastics Inc. was acquired in May 2004 and now operates as Imperial Plastics Inc.
- w) Kam Plastics Corp., previously Kam Industries LLC, is now partly employee-owned.
- x) True Precision Plastics LLC previously was listed as MPC Industries LLC
- y) Plastronics Plus Inc. previously was ranked under the name of parent Newcor Inc.
- z) In January 2005, UTI Corp. changed its name to Accellent Inc. and is moving its headquarters to the Boston area.
- aa) Previously listed Plastic Components Inc. was acquired by Hampson Corp. in July 2004.
- bb) Pent Custom Molding previously was listed as Pent Plastics Inc.
- cc) Advanced Plastics Inc. was acquired in August 2004 and now operates as EPI Advanced LLC.
- dd) Acorn-Gencon Plastics LLC acquired Dart Plastics & Engineering Inc. last year.
- ee) Humphrey Line Inc. previously was listed under parent Molded Container Corp., which consolidated into its Humphrey division.
- ff) Molding Services of Illinois Inc. previously was listed as Molding Systems Corp.
- gg) Hope Industries Inc. previously was listed as Rauschert Injection Molding Inc.
- hh) Gator Plastics Inc. previously was listed as Disposable Plastics.
- ii) Stacktech Systems California Ltd. previously was listed as Fairway Molds Inc.

[ [Back to Search](#) ]

---

[Home](#) | [About us](#) | [Contact us](#) | [Premium content & access policies](#)  
[Web site technical information](#) | [Privacy policy](#)

Entire contents copyright 2005 by Crain Communications Inc.  
All rights reserved.      [Terms & Conditions](#)

For information about this web site contact [webmaster@plasticsnews.com](mailto:webmaster@plasticsnews.com)

**INJECTION**

**MOLDING**

**HANDBOOK**

**THIRD EDITION**

---

**EDITED BY**

**DOMINICK V. ROSATO, P. E.**

**DONALD V. ROSATO, PH.D.**

**MARLENE G. ROSATO, P. E.**



**Kluwer Academic Publishers**  
Boston/Dordrecht/London



---

**Distributors for North, Central and South America:**

**Kluwer Academic Publishers**

101 Philip Drive

Assinippi Park

Norwell, Massachusetts 02061 USA

Telephone (781) 871-6600

Fax (781) 871-6528

E-Mail <kluwer@wkap.com>

**Distributors for all other countries:**

**Kluwer Academic Publishers Group**

Distribution Centre

Post Office Box 322

3300 AH Dordrecht, THE NETHERLANDS

Telephone 31 78 6392 392

Fax 31 78 6546 474

E-Mail <orderdept@wkap.nl>



Electronic Services <<http://www.wkap.nl>>

---

**Library of Congress Cataloging-in-Publication Data**

Injection molding handbook / Dominick V. Rosato, Donald V. Rosato, Marlene G. Rosato. - 3<sup>rd</sup> ed.

p. cm.

ISBN 0-7923-8619-1

1. Injection molding of plastics--Handbooks, manuals, etc. I. Rosato, Dominick V. II. Rosato, Donald V. III. Rosato, Marlene G.

TP1150.I55 2000

668.4'12--dc21

99-049946

---

Copyright © 2000 by Kluwer Academic Publishers.

All rights reserved. No part of this publication may be reproduced, stored in a retrieval system or transmitted in any form or by any means, mechanical, photo-copying, recording, or otherwise, without the prior written permission of the publisher, Kluwer Academic Publishers, 101 Philip Drive, Assinippi Park, Norwell, Massachusetts 02061

This students edition for sale only in the Republic of China

Distributed by: SCI-TECH Publishing Co., Ltd.

# Injection Molding Machines

## Introduction

The injection molding machine (IMM) is one of the most significant and rational forming methods existing for processing plastic materials. A major part in this development has been by the forward-thinking machinery industry, which has been quick to seize on innovations and incorporate them into plastic molded products. The most recent examples are the all-electric and hybrid IMMs. A major focus continues to be on finding more rational means of processing the endless new plastics that are developed and also produce more cost-efficient products. A simplified general layout for an IMM is shown in Figs. 2-1 and 1-3.

For years so-called *product innovation* was the only rich source of new developments, such as reducing the number of molded product components by making them able to perform a variety of functions or by taking full use of material's attributes. In recent years, however, *process innovation* has also been moving into the forefront (Fig. 1-16). The latter includes all the means that help tighten up the manufacturing process, reorganizing and optimizing it. All activity is targeted for the most efficient application of production materials, a principle which must run right through the entire process from plastic materials to the finished product (Fig. 1-15 and Chap. 4).

Even though modern IMM with all its ingenious microprocessor control technology is in principle suited to perform flexible tasks, it nevertheless takes a whole series of peripheral auxiliary equipment to guarantee the necessary degree of flexibility. Examples include (1) raw material supply systems; (2) mold transport facilities; (3) mold preheating banks; (4) mold-changing devices, including rapid clamping and coupling equipment; (5) plasticizer-cylinder-changing devices; (6) molded-product handling equipment, particularly robots with interchangeable arms allowing adaptation to various types of production; and (7) transport systems for finished products and handling equipment to pass molded products on to subsequent production stages.

There are different types and capacities of IMMs to meet different product and cost-production requirements. The types are principally horizontal single clamping units with reciprocating and two-stage plasticators. They range in injection capacity (shot size) from less than an ounce to at least 400 oz (usually from 4 to 100 oz) and in clamp tonnage up to at least 10,000 tons (usual from 50 to 600 tons). Other factors when specifying an IMM include clamp stroke, clamping speed, maximum daylight, clearances between tie rods, plasticating capacity, injection pressure, injection speed, and so on, as reviewed in this chapter and Chap. 4. The



0003-4878(94)00100-6

Attachment E

## EMISSIONS FROM PROCESSING THERMOPLASTICS

M. J. Forrest, A. M. Jolly, S. R. Holding and S. J. Richards  
Rapra Technology Ltd, Shawbury, Shrewsbury, Shropshire SY4 4NR, U.K.

(Received 9 May 1994 and in final form 9 August 1994)

**Abstract**—A 2-year study has been carried out into the emissions produced during the processing of thermoplastic materials. One of the main reasons for the inception of the work was the perceived need by the plastics processing industry and material suppliers for data in order to comply with recent work-place legislation. Very few data obtained under 'real life' situations were available for consultation prior to the start of this study. The principal objective of the project therefore was to determine the effect that the processing of thermoplastics had on the workplace environment by the collection both of qualitative and of quantitative chemical data. During the study a wide range of bulk commercial thermoplastic materials were covered, including polyvinyl chloride (PVC), Nylon 6, acrylonitrile-butadiene-styrene (ABS), high impact polystyrene (HIPS), low density polyethylene (LDPE) and high density polyethylene (HDPE). In order to investigate the effect the type of process had on the emissions produced two principal fabrication methods were studied, namely injection moulding and extrusion-based processes.

A wide range of species was detected in each process environment, it being possible to detect the relevant monomer(s) in some cases. However, none of the situations studied were found to generate a high level of process fume. The concentrations of the species detected were found to be in the range 0-2 mg m<sup>-3</sup> under standard processing conditions and up to ~10 mg m<sup>-3</sup> during purging operations. In none of the situations studied was any individual chemical species found at a concentration above the present occupational exposure limit. The data obtained shows that a higher level of fume is generated by extrusion-based processes than by those involving injection moulding.

Emissions data were obtained both by personal exposure monitoring and from a number of static monitors positioned around the process equipment. This revealed the important effect that the monitoring position had on the data generated and the need to employ an effective sampling strategy if representative data was to be obtained. The results obtained also showed how the choice of sampling adsorbent could influence the data obtained. Tenax has been found to be a satisfactory general-purpose adsorbent material for this type of study.

## INTRODUCTION

Legislation concerned with the management of health and safety in the workplace has been a major consideration for all concerned in recent years. It was perceived possible that employees working in the thermoplastics industry could be exposed to a health hazard since it was known that volatile chemical species were associated with the various fabrication processes employed. Although a number of studies concerned with the characterization of the species produced when thermoplastic materials are heated to elevated temperatures have been undertaken in the laboratory (Shmuilovich *et al.*, 1981; Hoff and Jacobsson, 1981; Lum and Kelleher, 1979) only a few workers have attempted to collect data from actual workplace situations.

Studies which are available in the literature include the investigation by Williamson and Kavanagh (1987) into vinylchloride monomer and other contaminants in PVC welding fumes, and the measurement of the depolymerization products in the polyacetal, polyamide and polymethacrylate industries (Vainiotalo and Pfaffli, 1989). In addition, Shaposhnikov *et al.* (1975) determined the volatile products during the processing of a limited number of polypropylene, PVC (polyvinylchloride) and ABS

1366 LINDEN DR. MADISON, WI 53716

(acrylonitrile-butadiene-styrene) plastics and Lemmen *et al.* (1989) have published data on the species produced during the processing of PVC.

An important contribution to this area is a work programme that was carried out by Hoff *et al.* (1982) in which both laboratory and process site data were collected on a number of thermoplastic materials.

In order to satisfy the demand for more comprehensive up-to-date 'real life' thermoplastic processing emissions data, this 2-year project was undertaken. During its lifetime 11 different thermoplastic-process combinations were evaluated. The principal objective was to determine the effect that the processing of thermoplastics had on the workplace environment by the compilation both of qualitative and quantitative emissions data. It was anticipated that the emissions produced for a given process would be mainly dependent on the material concerned.

Therefore during this study a wide range of important commercial thermoplastics was covered. It was also expected that in addition to material type a number of other factors would play an important role. The opportunity was therefore taken to investigate the effect of the type of process used on the emissions produced. Other important aspects of the study were likely to be any findings concerning the effect of ventilation, the relation of the monitoring position relative to the process and the location of the activity within the production site.

From a subjective point of view the act of purging a thermoplastic processing machine results in a much greater concentration of fume emission than that which is produced under standard processing conditions. Part of the study was aimed at obtaining a better understanding of the contribution made by this aspect of the process.

The principal sampling technique used throughout this study was based on adsorbent tubes which were subsequently analysed by thermal desorption gas chromatography-mass spectrometry (GC-MS). This analytical method is already used extensively to provide environmental data (HSE, 1987, 1989 and 1992). The principal limitation of this method is the specificity of the adsorbents used, with no adsorbents being regarded as completely universal in performance. Sampling methods which use adsorbent tubes with a subsequent solvent desorption stage prior to analysis were also used and a secondary objective of this project was a limited comparison of the two types of analysis technique.

Although some specific techniques were employed for certain species (e.g. liquid bubblers for hydrogen cyanide) it was not an aim of this project to carry out a wide range of specific analytical techniques for species such as aldehydes, etc. As a consequence, species which were present at a very low concentration, and for which the thermal desorption techniques used were not the most effective method of sampling, may have remained undetected. This could obviously be of importance for substances which have a very low occupational exposure limit. It should be pointed out therefore that the scope of this project did not extend to a full exposure assessment of the thermoplastic processing situations under study.

#### SAMPLING STRATEGY

The sampling strategy used to collect atmospheric samples can have a dramatic effect on the data produced. An important facet of this study was the development of a sampling strategy which would provide the best opportunity to collect representative

data on the specific situations of interest. The salient points of the sampling strategy used to collect samples are as follows:

- (a) where there was a chance to obtain representative personal exposure data this was carried out. However, if no operator was associated with any given process for a significant period a static monitor was placed in the position where the operative would normally be situated. Such samples are from hereon referred to using the term 'static-operator';
- (b) in the majority of the monitoring situations an attempt was made to investigate the effect that purging of the machine had on the emissions produced;
- (c) all static monitors were placed approximately 1.5 m from the floor, and at the following distances from the process:  
Background monitors: 4-6 m, and  
Process (Machine) monitors: 0.5-3 m;
- (d) in the monitoring positions chosen stainless steel tubes packed with one or more of the following, Tenax, Chromosorb or Poropak, were employed. In addition glass NIOSH type tubes packed with charcoal were used for plastics where monomers might be present for which there were established solvent desorption based methods;
- (e) to evaluate reproducibility duplicate determinations were carried out on selected monitoring positions during certain monitoring situations. Examples of these determinations are shown in the data tables; and
- (f) where liquid bubblers were to be used for the determination of hydrogen cyanide, they were placed either side of the process machine at a distance of approximately 1.5 m.

#### SUMMARY OF THE SITUATIONS STUDIED

- (1) Material: Acrylonitrile-butadiene-styrene, ABS  
Process: Injection moulding  
Environment: A
- (2) Material: High impact polystyrene, HIPS  
Process: Injection moulding  
Environment: A
- (3) Material: HIPS  
Process: Sheet extrusion  
Environment: A
- (4) Material: High density polyethylene, HDPE  
Process: Blow moulding  
Environment: C
- (5) Material: Low density polyethylene, LDPE  
Process: Blown film  
Environment: C
- (6) Material: A low density polyethylene-linear low density polyethylene blend, LDPE-LLDPE  
Process: Blown film  
Environment: B
- (7) Material: Nylon 6

- Process: Extrusion  
Environment: A
- (8) Material: Polypropylene  
Process: Tape extrusion  
Environment: B
- (9) Material: PVC (rigid)  
Process: Injection moulding  
Environment: A
- (10) Material: PVC (plasticised)  
Process: Cable extrusion  
Environment: B
- (11) Material: SAN  
Process: Injection moulding  
Environment: A

*Environment key*

- A = Work area where a number of different materials were being processed nearby.  
B = Work area where the majority or all of the nearby machines were processing the same material as the one being studied.  
C = Experimental process area where there were little or no other processes taking place nearby.

#### SAMPLING AND ANALYSIS

A measure of the total volatile organic compounds present was obtained at each sampling point using thermal desorption tubes packed with 150 g of adsorbent. Samples were obtained at a flow rate of  $100 \text{ ml min}^{-1}$ , with the sample size varying from 10 to 15 l.

The contents of the adsorbent tubes were desorbed at  $250^\circ\text{C}$  using an SKC thermal desorption unit with subsequent analysis of the desorbed species by a Finnigan 1050 GC-MS instrument. A liquid carbon dioxide on-column cold focus technique was employed using an SGE CTS-CL02 system with a Chrompak CB Sil 5CB  $25 \text{ m} \times 0.32 \text{ mm}$  capillary column heated at  $40^\circ\text{C}$  for 12 min initially and then at  $5^\circ\text{C min}^{-1}$  to  $250^\circ\text{C}$ . Mass spectral data were obtained by scanning the range 35–450 atomic mass units every 2 s. The Chromatogram peak assignments were obtained using the Finnigan National Bureau of Standards Library, with manual searching of the Royal Society of Chemistry Library and the National Institute of Health/Environmental Protection Agency Libraries where appropriate. Quantification data were obtained by calibrating with decane standards over the range  $0.02\text{--}1 \mu\text{g}$ .

Where appropriate, specific sampling for the monomers styrene and acrylonitrile was carried out at each sampling point using NOISH type charcoal tubes (100/50 mg). The sampling rate was  $100 \text{ ml min}^{-1}$ , and the sample size varied from 10 to 15 l. The contents of the tubes was desorbed using carbon disulphide and the amounts of styrene and acrylonitrile obtained using the analysis methods MDHS No. 20 and No. 1, respectively.

The sampling of hydrogen cyanide present during the processing of ABS and SAN was determined in each case using two liquid bubblers, filled with 10 ml of 0.1 m NaOH solution. The amount of hydrogen cyanide was then determined by analysing the

contents of the bubblers in 100  $\mu\text{l}$  aliquots using a Waters ion chromatograph fitted with a Waters IC Pak HC Anion Column. A 5 mM KOH mobile phase was used at a flow rate of 2 ml  $\text{min}^{-1}$ , with conductivity detection. Calibration curves were produced using potassium cyanide standards in the range 1–50 ppm.

During this study spot measurements for the species hydrogen cyanide, formaldehyde and hydrogen chloride were carried out using Draeger and Gastech tubes.

## RESULTS AND DISCUSSION

The data obtained using thermal desorption, solvent desorption and specific techniques have, for convenience, been segregated according to polymer type.

To produce tables that were of a manageable size the thermal desorption data have been edited to remove species of which the concentrations were below 0.1 or 0.01  $\text{mg m}^{-3}$ , depending on the situation. Also, the term not detected (nd) indicates that the species was not detected above the systems detection limit, which was approximately  $1 \times 10^{-4} \text{ mg m}^{-3}$ .

### (1) Acrylonitrile-butadiene-styrene (ABS)

*Thermal desorption results.* The thermal desorption results obtained for this material using Tenax are shown in Table 1. It can be seen that a wide range of different chemical species and of varying concentrations was observed. As expected, the concentrations of all species were higher during purging, but what had not been anticipated was the relatively high concentrations of many species in the background, the differences between the background and the monitoring positions close to the injection moulder being quite small.

It was possible to detect the monomers styrene and acrylonitrile (2-propenenitrile), and a modifier ( $\alpha$ -methyl styrene) which had been added at the polymerization stage. Butadiene was not detected and this is thought to be due to its low residual concentration in the polymer as a consequence of its highly volatile nature.

*Solvent desorption results.* Charcoal tubes with solvent desorptions were used to monitor both for acrylonitrile and for styrene. The determinations were carried out both under standard processing conditions and during purging. In none of the monitoring positions was styrene detected above the method detection limit of 0.4  $\text{mg m}^{-3}$  (10 l. sample of air), or acrylonitrile above the method detection limit of 2.2  $\text{mg m}^{-3}$  (20 l. sample of air). Both of these species were detected by the method based on thermal desorption because of its lower detection limit.

*Determination of hydrogen cyanide.* The emissions produced were monitored for the presence of hydrogen cyanide using both specific detection tubes (Draeger) and ion chromatography.

Spot measurements were taken using Draeger tubes during the period that the injection moulder was operating under standard conditions and during the purging operation. The measurements during standard conditions were taken in the area that the operator occupied and this was approximately 1.5–2 m from the nozzle. During purging, measurements were taken in the fume directly ( $\sim 10$ –15 cm) above the purge

Table 1. Emissions data obtained on ABS during an injection moulding process using Tenax

ABS—injection moulding Adsorbent, Tenax; Melt temperature, 245°C				
Tube 1 static—background				
Tube 2 static—operator/machine				
Tube 3 operator				
Tube 4 static—machine (purging)				
Compound	Concentration			
	Tube 1 (mg m <sup>-3</sup> )	Tube 2 (mg m <sup>-3</sup> )	Tube 3 (mg m <sup>-3</sup> )	Tube 4 (mg m <sup>-3</sup> )
2-Propenenitrile	nd	nd	nd	0.02
Hydrocarbon (~C <sub>5</sub> -C <sub>7</sub> )	0.01	0.01	<0.01	<0.01
Trichloromethane	nd	<0.01	<0.01	0.02
1,1,1-Trichloroethane	<0.01	<0.01	nd	nd
Benzene	<0.01	<0.01	nd	nd
Trichloroethene	0.01	<0.01	<0.01	nd
Unknown	<0.01	nd	nd	nd
Alcohol (~C <sub>5</sub> )	0.01	0.03	0.01	nd
Toluene	0.02	0.02	0.02	0.03
Hydrocarbon (~C <sub>8</sub> -C <sub>10</sub> )	0.01	0.01	0.01	<0.01
Unknown	<0.01	nd	<0.01	nd
Xylene isomers	0.03	0.03	0.02	0.01
Styrene	0.01	0.02	0.01	0.20
Hydrocarbon (~C <sub>10</sub> -C <sub>12</sub> )	0.01	<0.01	0.02	0.04
Alcohol (~C <sub>7</sub> )?	0.01	0.01	0.01	0.02
Benzene, methyl, ethyl isomers	<0.01	0.01	<0.01	0.03
Benzene, propyl isomer	<0.01	<0.01	<0.01	nd
Unknown	nd	nd	nd	0.03
Benzene, trimethyl isomers	0.02	0.02	0.02	<0.01
Alpha methyl styrene	<0.01	0.01	<0.01	0.30
Benzene, ethenyl, methyl isomers	<0.01	<0.01	<0.01	0.22
Benzene, dichloroisomer	0.01	0.01	0.01	nd
Acetophenone	nd	<0.01	nd	nd
Benzene, diethyl isomer	nd	<0.01	nd	nd
Unknown	nd	<0.01	nd	nd
Hydrocarbon (~C <sub>12</sub> -C <sub>14</sub> )	0.04	0.06	0.04	0.07
Benzene, ethyl, dimethyl isomers	0.01	<0.01	0.01	<0.01
Benzene, methyl, diethyl isomers	<0.01	<0.01	nd	nd
Naphthalene, tetrahydro isomer	<0.01	nd	<0.01	nd
Benzene, ethyl, methylethyl isomer	nd	nd	<0.01	nd
Siloxane	0.01	0.01	0.01	nd
Unknown	nd	0.01	<0.01	nd
Naphthalene, tetrahydro, methyl isomers	<0.01	0.01	<0.01	<0.01
BHT	nd	<0.01	<0.01	nd
Alcohol (~C <sub>12</sub> )?	<0.01	<0.01	<0.01	nd

nd = not detected.

waste and in the same operator position as that used during normal operation. It was not possible to detect hydrogen cyanide above the detection limit of the Draeger tube (2 ppm) on any occasion.

Direct analysis by ion-chromatography of the contents of the sampling bubblers did not reveal any peaks at an elution time which corresponded to that of the cyanide ion. No hydrogen cyanide was therefore detectable by this method, the detection limit of which was calculated as being approximately 0.5 ppm of the airborne species.



*Determination of formaldehyde.* The emissions present under standard processing conditions and during processing were examined for the presence of formaldehyde, using Draeger tubes having a detection limit of 0.2 ppm. Using the same sampling strategy as for the determination of hydrogen cyanide, no formaldehyde was detected above the detection limit.

(2) *High impact polystyrene (HIPS)*

*Thermal desorption results.* For the sheet extrusion study (Table 2) monitoring was only undertaken using Tenax adsorbent tubes, and while a range of different chemical species were identified they were all at comparatively low levels. The species detected

Table 2. Emissions data obtained on HIPS during a sheet extrusion process using Tenax

Compound	HIPS—sheet extrusion Adsorbent, Tenax; Melt temperature, 193°C			
	Tube 1 (mg m <sup>-3</sup> )	Tube 2 (mg m <sup>-3</sup> )	Tube 3 (mg m <sup>-3</sup> )	Tube 4 (mg m <sup>-3</sup> )
Acrylonitrile	nd	nd	nd	0.01
Methyl propenoic acid, methyl ester	nd	0.01	<0.01	0.07
Toluene	<0.01	0.01	<0.01	0.05
Ethenyl cyclohexene	<0.01	0.01	<0.01	0.14
Xylene isomers	<0.01	0.03	0.01	0.38
Styrene	0.03	0.13	0.05	1.48
Hydrocarbon (~C <sub>8</sub> -C <sub>10</sub> )	<0.01	0.01	0.01	0.02
Propyl benzene isomers	<0.01	0.01	<0.01	0.13
Alpha methyl styrene	<0.01	0.01	<0.01	0.10
Ethenyl dimethyl cyclohexene	<0.01	0.20	<0.01	<0.01
Acetophenone	<0.01	<0.01	<0.01	0.02
Propenyl benzene isomers	<0.01	0.01	<0.01	0.02
Hydrocarbon (~C <sub>10</sub> -C <sub>12</sub> )	<0.01	0.02	<0.01	0.01

nd = not detected.

were primarily aromatic in nature, styrene being one of the most prominent. The data produced during this study illustrated well how the position of a process within a workplace can effect the concentration of the species detected around it. The monitor positioned between the process and the adjacent sidewall of the work area (Static—Machine 2) recorded higher concentrations of species than the one positioned on the other side of the process which was open (Static—Machine 1). For this work owing to work schedules it was not possible to monitor during a purging operation.

With the injection moulding of HIPS both Tenax and Chromosorb adsorbent tubes were used (Tables 3 and 4). A wider range of chemical species were observed and at significantly higher concentrations than for the sheet extrusion. However, the background concentrations of most species were not much lower than in the monitoring positions adjacent to the process. A comparison of the data from the two types of adsorbent gave generally similar results. Purging was monitored with both tube types and significantly higher levels of most species were found.

Table 3. Emissions data obtained on HIPS during an injection moulding process using Tenax

HIPS— injection moulding				
Adsorbent, Tenax; Melt temperature, 225°C				
Tube 1 static—machine/operator				
Tube 2 static—background				
Tube 3 operator				
Tube 4 static—machine (purge area)				
Compound	Concentration			
	Tube 1 (mg m <sup>-3</sup> ) (standard)	Tube 2 (mg m <sup>-3</sup> ) (standard)	Tube 3 (mg m <sup>-3</sup> ) (standard)	Tube 4 (mg m <sup>-3</sup> ) (purge)
Dichloromethane	0.36	0.25	0.36	0.27
Toluene	0.31	0.28	0.25	0.32
Alcohol (C <sub>5</sub> )	0.33	0.30	0.22	0.46
Hydrocarbon (~C <sub>7</sub> )	0.13	<0.1	<0.1	<0.1
Xylene	1.60	0.66	0.49	0.40
Hydrocarbon (~C <sub>9</sub> )	<0.1	0.12	<0.1	<0.1
Propylbenzene	<0.1	0.38	<0.1	nd
Benzene, ethyl, methyl isomer	0.21	0.18	<0.1	<0.1
Benzene, ethyl, methyl isomer	0.12	0.10	<0.1	nd
Benzene, trimethyl isomer	0.31	0.28	0.13	0.12
Benzene, dichloro isomer	0.65	0.46	0.78	0.50
Benzene, trimethyl isomer	<0.1	0.25	<0.1	nd
Hydrocarbon (~C <sub>10</sub> )	0.42	0.25	0.21	0.17
Hydrocarbon (~C <sub>11</sub> )	0.66	0.47	0.33	0.21
Hydrocarbon (~C <sub>12</sub> )	0.62	0.38	0.21	0.12
Hydrocarbon (~C <sub>13</sub> )	0.15	0.15	<0.1	<0.1

nd = not detected.

*Solvent desorption results.* Charcoal adsorbent tubes with subsequent solvent desorption were used to monitor for styrene during the injection moulding of HIPS. Determinations were carried out both under standard processing conditions and during purging. No styrene was detected above the method detection limit of 0.4 mg m<sup>-3</sup> (10 l. sample of air) in any monitoring position. As in the case of the ABS data, it was possible to detect the presence of styrene using the thermal desorption technique because of the greater sensitivity of the method.

### (3) High density polyethylene (HDPE)

High density polyethylene was studied only with regard to a single blow moulding situation. The results obtained using the thermal desorption GC-MS technique are shown in Table 5. Since blow moulding is a process that inherently produces little fume, it is possibly not surprising that very low concentrations of species were detected. Simple hydrocarbons and toluene at a very low concentration were all that was observed. The fact that the process was being carried out in a very clean environment with few other processes operating at the time helped to minimize the concentration of species found.

Purging was not carried out during the study period with this process and so it was not possible to study its effect on the emissions produced.

Table 4. Emissions data obtained on HIPS during an injection moulding process using Chromosorb

HIPS— injection moulding				
Adsorbent, Chromosorb; Melt temperature, 225°C				
Tube 1 static—machine/operator				
Tube 2 static—background				
Tube 3 operator				
Tube 4 static—machine (purge area)				
Compound	Concentration			
	Tube 1 (mg m <sup>-3</sup> ) (standard)	Tube 2 (mg m <sup>-3</sup> ) (standard)	Tube 3 (mg m <sup>-3</sup> ) (standard)	Tube 4 (mg m <sup>-3</sup> ) (purge)
Acetone	0.17	0.16	<0.1	<0.1
Dichloromethane	1.23	0.87	0.33	0.80
Unknown	0.11	0.14	<0.1	0.11
1,1,1 Trichloroethane	0.43	0.34	0.19	0.19
Benzene	<0.1	0.16	<0.1	<0.1
Methyl methacrylate	<0.1	0.15	<0.1	nd
Toluene	0.40	0.69	0.29	0.17
Alcohol (C <sub>5</sub> )	0.41	0.59	nd	<0.1
Hydrocarbon (~C <sub>9</sub> )	0.16	0.17	<0.1	<0.1
Xylene	1.30	0.99	0.48	0.59
Hydrocarbon (~C <sub>10</sub> )	0.12	0.37	<0.1	<0.1
Propylbenzene	0.13	<0.1	<0.1	nd
Benzene, ethyl, methyl isomer	0.22	0.21	0.10	<0.1
Benzene, ethyl, methyl isomer	<0.1	0.10	<0.1	nd
Benzene, trimethyl isomer	0.35	0.31	0.27	nd
Benzene, dichloro isomer	0.75	0.83	0.76	0.21
Hydrocarbon (~C <sub>11</sub> )	0.37	0.83	0.31	<0.1
Benzene, trimethyl isomer	0.13	0.12	0.10	nd
Hydrocarbon (~C <sub>12</sub> )	0.38	<0.1	0.33	<0.1
Hydrocarbon (~C <sub>13</sub> )	0.23	nd	0.18	<0.1

nd = not detected.

Table 5. Emissions data obtained on HDPE during a blow moulding process using Tenax

HDPE—blow moulding				
Adsorbent, Tenax; Melt temperature, 210°C				
Tube 1 static—background				
Tube 2 static—machine (1)				
Tube 3 static—machine (2)				
Tube 4 operator				
Compound	Concentration			
	Tube 1 (mg m <sup>-3</sup> )	Tube 2 (mg m <sup>-3</sup> )	Tube 3 (mg m <sup>-3</sup> )	Tube 4 (mg m <sup>-3</sup> )
Hydrocarbon (~C <sub>5</sub> -C <sub>7</sub> )	0.01	<0.01	<0.01	0.01
Toluene	<0.01	<0.01	<0.01	0.01
Hydrocarbon (~C <sub>8</sub> -C <sub>10</sub> )	0.01	<0.01	<0.01	<0.01
Hydrocarbon (~C <sub>10</sub> -C <sub>12</sub> )	<0.01	0.01	<0.01	0.01
Hydrocarbon (~C <sub>12</sub> -C <sub>14</sub> )	0.01	0.01	0.01	0.03

(4) *Nylon 6*

Nylon 6 used in an extrusion process was studied on one occasion with both Tenax and Chromosorb tubes. Various chemical species were observed at relatively high concentrations (including the background). Similar results were obtained for both types of tube (Tables 6 and 7).

Table 6. Emissions data obtained on Nylon 6 during an extrusion process using Chromosorb

Nylon 6—extrusion					
Adsorbent, Chromosorb; Melt temperature, 276°C					
Tube 1 operator					
Tube 2 static—machine (purge)					
Tube 3 static—background (purge)					
Tube 4 static—machine					
Tube 5 static—background					
Compound	Concentration				
	Tube 1 (mg m <sup>-3</sup> ) (standard)	Tube 2 (mg m <sup>-3</sup> ) (purge)	Tube 3 (mg m <sup>-3</sup> ) (purge)	Tube 4 (mg m <sup>-3</sup> ) (standard)	Tube 5 (mg m <sup>-3</sup> ) (standard)
Chlorodifluoromethane	nd	nd	0.86	nd	nd
Ethane, 1-chloro-1, 1-difluoro-	nd	nd	0.24	nd	nd
Acetone	<0.1	nd	0.76	<0.1	nd
Dichloromethane	<0.1	<0.1	1.04	<0.1	<0.1
Benzene	<0.1	<0.1	0.31	<0.1	<0.1
Hydrocarbon (~C <sub>6</sub> -C <sub>8</sub> )	<0.1	0.18	0.91	<0.1	<0.1
Methyl methacrylate	nd	0.35	0.45	<0.1	nd
Toluene	<0.1	0.12	0.84	<0.1	<0.1
Butane, 1-chloro, 3-methyl-	nd	nd	0.11	nd	nd
Xylene	<0.1	nd	0.52	<0.1	<0.1
a-Methyl styrene	<0.1	<0.1	0.84	<0.1	<0.1
Hydrocarbon (~C <sub>9</sub> -C <sub>12</sub> )	<0.1	0.27	0.11	<0.1	<0.1

nd = not detected.

On this occasion, the background environment as well as the airborne species which were close to the process were monitored during purging and, interestingly, the concentrations of most chemical species in the background were considerably higher than those near to the process. This apparently anomalous situation is thought to be due to the fact that other working practices, such as product testing, were being carried out in the close vicinity and species from these (e.g. solvents) could have made a significant contribution.

(5) *Polypropylene*

The fumes emitted during the tape extrusion of polypropylene were studied using both Tenax and Chromosorb (Tables 8 and 9). On this occasion there was a perceptible draught in the vicinity of the process and monitoring was undertaken both upwind and downwind to investigate its effect on the collected data. The background was monitored both during purging and during standard processing conditions.

The chemical species observed included mostly hydrocarbons and some aromatics but at comparatively high levels. Not surprisingly, the levels of fume found downwind were significantly higher than those detected upwind. In this case the effect of purging did not appear to be as dramatic as with some of the processes. The relationship

Table 7. Emissions data obtained on Nylon 6 during an extrusion process using Tenax

Nylon 6—extrusion					
Adsorbent, Tenax; Melt temperature, 276°C					
Tube 1 operator					
Tube 2 static—machine (purge)					
Tube 3 static—background (purge)					
Tube 4 static—machine					
Tube 5 static—background					
Compound	Concentration				
	Tube 1 (mg m <sup>-3</sup> ) (standard)	Tube 2 (mg m <sup>-3</sup> ) (purge)	Tube 3 (mg m <sup>-3</sup> ) (purge)	Tube 4 (mg m <sup>-3</sup> ) (standard)	Tube 5 (mg m <sup>-3</sup> ) (standard)
Acetone	<0.1	<0.1	0.22	nd	nd
Dichloromethane	<0.1	0.13	0.53	<0.1	<0.1
Hydrocarbon (~C <sub>5</sub> -C <sub>7</sub> )	<0.1	0.16	0.71	<0.1	nd
Toluene	<0.1	0.19	0.59	<0.1	<0.1
Xylene	<0.1	<0.1	3.22	<0.1	<0.1
Hydrocarbon (~C <sub>8</sub> -C <sub>10</sub> )	<0.1	0.65	3.40	<0.1	0.68
a-Methyl styrene	<0.1	0.63	7.67	<0.1	0.39
Benzene, methyl (1-methylethyl)-	nd	0.14	1.69	nd	<0.1
Benzene, methyl, propyl isomer	nd	nd	nd	nd	0.10
Benzene, methyl, propyl isomer	nd	nd	nd	nd	0.11
Benzene, (1,1-dimethyl, ethyl)-	nd	nd	nd	nd	0.12
Benzene, 1-methyl-4-(methylethyl)-	nd	nd	nd	nd	0.12
Benzene, (1-ethylpropyl)-	nd	nd	nd	nd	0.12
Hydrocarbon (~C <sub>9</sub> -C <sub>11</sub> )	<0.1	1.58	5.80	<0.1	0.57
Naphthalene, 1,2,3,4-tetrahydro-	nd	nd	nd	nd	0.13
Hydrocarbon (~C <sub>10</sub> -C <sub>13</sub> )	<0.1	<0.1	0.55	0.16	0.86
BHT	nd	nd	0.28	nd	nd

nd = not detected.

between the Tenax and Chromosorb tube results were generally as reported for other plastics-process combinations.

#### (6) Polyvinylchloride (PVC)

*Thermal desorption results.* The injection moulding of unplasticised PVC was monitored using both Tenax and Chromosorb adsorbent tubes; while the cable extrusion of plasticized PVC was monitored using Tenax and Poropak.

For the injection moulding work, comparatively high concentrations of a wide variety of chemical species were observed (Tables 10 and 11) and once again the background during purging showed concentrations of some species higher than those obtained close to the process itself. From the data it can be seen that the background environment during purging altered compared to that which existed during normal operating conditions. The monomer type species found, although not thought to originate from the study compound, could originate from additives in PVC compounds being processed nearby. The purging operation was found to enhance the concentrations of species found, which is to be expected.

For the cable extrusion study the range and concentrations of species observed were both relatively small (Table 12). Although some process fume was apparent

Table 8. Emissions data obtained on polypropylene during a tape extrusion process using Tenax

Polypropylene—tape extrusion					
Adsorbent, Tenax; Melt temperature, 240°C					
Tube 1 static—background					
Tube 2 static—machine/operator (upwind side of die)					
Tube 3 static—machine/operator (downwind side of die)					
Tube 1 static—machine/operator (purging)					
Tube 2 static—background (purging)					
Compound	Concentration				
	Tube 1 (mg m <sup>-3</sup> ) (standard)	Tube 2 (mg m <sup>-3</sup> ) (standard)	Tube 3 (mg m <sup>-3</sup> ) (standard)	Tube 1 (mg m <sup>-3</sup> ) (purge)	Tube 2 (mg m <sup>-3</sup> ) (purge)
Hydrocarbon (~C <sub>5</sub> -C <sub>7</sub> )	0.48	0.22	1.65	0.27	0.23
Xylene	0.37	nd	nd	<0.1	<0.1
Hydrocarbon (~C <sub>6</sub> -C <sub>8</sub> )	0.37	0.74	0.35	<0.1	<0.1
a-Methyl styrene	0.16	<0.1	nd	0.11	nd
Hydrocarbon (~C <sub>7</sub> -C <sub>9</sub> )	0.58	0.46	1.79	1.05	0.79
Hydrocarbon (~C <sub>8</sub> -C <sub>10</sub> )	0.73	0.67	2.98	0.32	0.17
Hydrocarbon (~C <sub>9</sub> -C <sub>11</sub> )	1.49	1.04	5.24	<0.1	0.23
Hydrocarbon (~C <sub>10</sub> -C <sub>12</sub> )	0.89	0.44	2.68	<0.1	0.14
Hydrocarbon (~C <sub>11</sub> -C <sub>13</sub> )	1.43	0.97	5.38	<0.1	0.87
Hydrocarbon (~C <sub>12</sub> -C <sub>14</sub> )	2.27	0.15	6.69	<0.1	0.23
Hydrocarbon (~C <sub>13</sub> -C <sub>15</sub> )	0.88	0.52	1.70	<0.1	<0.1

nd = not detected.

Table 9. Emissions data obtained on polypropylene during a tape extrusion process using Chromosorb

Polypropylene—tape extrusion					
Adsorbent, Chromosorb; Melt temperature, 240°C					
Tube 1 static—background					
Tube 2 static—machine/operator (upwind side of die)					
Tube 3 static—machine/operator (downwind side of die)					
Tube 1 static—machine/operator (purging)					
Tube 2 static—background (purging)					
Compound	Concentration				
	Tube 1 (mg m <sup>-3</sup> ) (standard)	Tube 2 (mg m <sup>-3</sup> ) (standard)	Tube 3 (mg m <sup>-3</sup> ) (standard)	Tube 1 (mg m <sup>-3</sup> ) (purge)	Tube 2 (mg m <sup>-3</sup> ) (purge)
Hydrocarbon (~C <sub>5</sub> -C <sub>7</sub> )	<0.1	0.15	0.57	<0.1	0.25
Hydrocarbon (~C <sub>6</sub> -C <sub>8</sub> )	<0.1	0.32	2.16	0.47	0.55
Hydrocarbon (~C <sub>7</sub> -C <sub>9</sub> )	0.17	0.58	0.92	<0.1	<0.1
Xylene	0.14	0.14	nd	nd	<0.1
Hydrocarbon (~C <sub>8</sub> -C <sub>10</sub> )	<0.1	0.44	0.66	<0.1	0.66
a-Methyl styrene	nd	<0.1	nd	<0.1	0.10
Hydrocarbon (~C <sub>9</sub> -C <sub>11</sub> )	<0.1	1.11	2.63	<0.1	2.45
Hydrocarbon (~C <sub>10</sub> -C <sub>12</sub> )	<0.1	0.14	1.27	<0.1	0.36
Hydrocarbon (~C <sub>11</sub> -C <sub>13</sub> )	<0.1	0.12	0.25	<0.1	1.09
Hydrocarbon (~C <sub>12</sub> -C <sub>15</sub> )	0.11	0.10	<0.1	<0.1	1.56
Benzene, alkyl derivative	<0.1	<0.1	nd	nd	0.40

nd = not detected.

Table 10. Emissions data obtained on PVC during an injection moulding process using Tenax

PVC—injection moulding					
Adsorbent, Tenax; Melt temperature, 180°C					
Tube 1 static—operator					
Tube 2 static—machine					
Tube 3 static—background					
Tube 4 static—machine (purge)					
Tube 5 static—background (purge)					
Compound	Concentration				
	Tube 1 (mg m <sup>-3</sup> ) (standard)	Tube 2 (mg m <sup>-3</sup> ) (standard)	Tube 3 (mg m <sup>-3</sup> ) (standard)	Tube 4 (mg m <sup>-3</sup> ) (purge)	Tube 5 (mg m <sup>-3</sup> ) (purge)
Dichloromethane	nd	<0.1	<0.1	1.72	1.13
Ethyl acetate	nd	0.60	0.84	0.68	0.64
Ethene, trichloro-	<0.1	0.13	0.12	<0.1	<0.1
Hydrocarbon (~C <sub>6</sub> -C <sub>8</sub> )	<0.1	<0.1	0.10	0.12	1.17
Toluene	<0.1	<0.1	<0.1	0.24	0.16
Benzene, chloro-	0.43	0.42	0.55	0.24	0.11
Xylene	<0.1	<0.1	<0.1	0.60	1.26
Cyclic alkene (C <sub>10</sub> -H <sub>16</sub> )	<0.1	0.15	0.14	0.12	0.10
<i>o</i> -Methyl styrene	nd	nd	nd	3.44	2.30
Benzene, alkyl derivative	nd	nd	nd	nd	0.15
Hydrocarbon (~C <sub>10</sub> -C <sub>12</sub> )	0.85	0.80	1.03	1.65	2.44
Benzene, methyl, propyl isomer	nd	nd	nd	nd	0.51
Hydrocarbon (~C <sub>11</sub> -C <sub>13</sub> )	<0.1	0.31	0.17	0.16	0.14

nd = not detected.

during the standard operating conditions, as in the injection moulding study, the material still does not appear to have made a significant impact on the species detected in its immediate vicinity, similar data being recorded for the background. It is only during purging that the concentrations of the species detected rise markedly compared to those in the background. This study also demonstrated (as others did in this project) how the position of a monitor in relation to a process can have a profound effect on the data collected. The Poropak adsorbent was found to give similar results to Tenax on this occasion.

No vinylchloride monomer was detected on either occasion and this is thought to be due to its low residual concentration in the resins.

*Determination of hydrogen chloride.* The emissions present during the cable extrusion processing of plasticized PVC were analysed for hydrogen chloride using a Gastec tube (detection limit 0.2 ppm). Measurements were taken at ~0.2 and ~0.04 m from the die with no hydrogen chloride being detected in either case. A further reading was taken at 0.1 m above the purge waste, in the fume that was given off, but again no hydrogen chloride was detected.

#### (7) Low density polyethylene and a low density polyethylene-linear low density polyethylene blend

The blown film processing of these two materials was studied in two quite different environments. The data obtained for the LDPE-LLDPE blend using Tenax and Chromosorb tubes (Tables 13 and 14) were more complex, which was in part due to the

1305 LINDEN DRIVE, MADISON, WISCONSIN, U.S.A.

Table 10. Emissions data obtained on PVC during an injection moulding process using Tenax

Compound	PVC—injection moulding Adsorbent, Tenax; Melt temperature, 180°C				
	Tube 1 (mg m <sup>-3</sup> ) (standard)	Tube 2 (mg m <sup>-3</sup> ) (standard)	Concentration Tube 3 (mg m <sup>-3</sup> ) (standard)	Tube 4 (mg m <sup>-3</sup> ) (purge)	Tube 5 (mg m <sup>-3</sup> ) (purge)
Tube 1 static—operator					
Tube 2 static—machine					
Tube 3 static—background					
Tube 4 static—machine (purge)					
Tube 5 static—background (purge)					
Dichloromethane	nd	<0.1	<0.1	1.72	1.13
Ethyl acetate	nd	0.60	0.84	0.68	0.64
Ethene, trichloro-	<0.1	0.13	0.12	<0.1	<0.1
Hydrocarbon (~C <sub>6</sub> -C <sub>8</sub> )	<0.1	<0.1	0.10	0.12	1.17
Toluene	<0.1	<0.1	<0.1	0.24	0.16
Benzene, chloro-	0.43	0.42	0.55	0.24	0.11
Xylene	<0.1	<0.1	<0.1	0.60	1.26
Cyclic alkene (C <sub>10</sub> ·H <sub>16</sub> )	<0.1	0.15	0.14	0.12	0.10
a-Methyl styrene	nd	nd	nd	3.44	2.30
Benzene, alkyl derivative	nd	nd	nd	nd	0.15
Hydrocarbon (~C <sub>10</sub> -C <sub>12</sub> )	0.85	0.80	1.03	1.65	2.44
Benzene, methyl, propyl isomer	nd	nd	nd	nd	0.51
Hydrocarbon (~C <sub>11</sub> -C <sub>13</sub> )	<0.1	0.31	0.17	0.16	0.14

nd = not detected.

during the standard operating conditions, as in the injection moulding study, the material still does not appear to have made a significant impact on the species detected in its immediate vicinity, similar data being recorded for the background. It is only during purging that the concentrations of the species detected rise markedly compared to those in the background. This study also demonstrated (as others did in this project) how the position of a monitor in relation to a process can have a profound effect on the data collected. The Poropak adsorbent was found to give similar results to Tenax on this occasion.

No vinylchloride monomer was detected on either occasion and this is thought to be due to its low residual concentration in the resins.

*Determination of hydrogen chloride.* The emissions present during the cable extrusion processing of plasticized PVC were analysed for hydrogen chloride using a Gastec tube (detection limit 0.2 ppm). Measurements were taken at ~0.2 and ~0.04 m from the die with no hydrogen chloride being detected in either case. A further reading was taken at 0.1 m above the purge waste, in the fume that was given off, but again no hydrogen chloride was detected.

(7) *Low density polyethylene and a low density polyethylene-linear low density polyethylene blend*

The blown film processing of these two materials was studied in two quite different environments. The data obtained for the LDPE-LLDPE blend using Tenax and Chromosorb tubes (Tables 13 and 14) were more complex, which was in part due to the

1308 LINDEN DR. MADISON, WI 53706



Table 11. Emissions data obtained on PVC during an injection moulding process using Chromosorb

PVC—injection moulding					
Adsorbent, Chromosorb; Melt temperature, 180°C					
Tube 1 static—operator					
Tube 2 static—machine					
Tube 3 static—background					
Tube 4 static—machine (purge)					
Tube 5 static—background (purge)					
Compound	Concentration				
	Tube 1 (mg m <sup>-3</sup> ) (standard)	Tube 2 (mg m <sup>-3</sup> ) (standard)	Tube 3 (mg m <sup>-3</sup> ) (standard)	Tube 4 (mg m <sup>-3</sup> ) (purge)	Tube 5 (mg m <sup>-3</sup> ) (purge)
Acetone	<0.1	<0.1	<0.1	0.17	0.15
Dichloromethane	<0.1	<0.1	<0.1	10.61	9.48
Ethyl acetate	1.51	1.23	1.27	0.77	1.19
Ethene, trichloro	0.24	0.15	0.17	nd	nd
Methyl methacrylate	nd	<0.1	0.13	0.27	0.41
Hydrocarbon (~C <sub>7</sub> -C <sub>9</sub> )	0.10	<0.1	0.21	<0.1	0.20
Toluene	<0.1	0.10	<0.1	0.29	0.33
Benzene, chloro-	0.59	0.46	0.54	0.17	0.43
Xylene	nd	<0.1	<0.1	nd	0.10
Cyclic hydrocarbon (alkene) C <sub>10</sub> H <sub>16</sub>	0.79	0.52	0.37	<0.1	0.32
a-Methyl styrene	<0.1	<0.1	nd	0.47	0.62
Hydrocarbon (~C <sub>10</sub> -C <sub>12</sub> )	0.68	0.32	0.86	<0.1	0.65
Benzene, butenyl isomer	<0.1	<0.1	0.19	nd	nd
Benzene, butenyl isomer	nd	nd	0.10	nd	nd

nd = not detected.

fact that it was being processed in a manufacturing environment and not, as with the LDPE (Table 15), in an experimental test site. With the blend, a larger range of chemical species were detected and the concentrations found were higher. The presence of certain known monomeric species (i.e. methyl methacrylate and a-methyl styrene) in this data is surprising given that the types of polymers that these species are normally associated with were not obviously in evidence at the site, but the concentrations found are relatively low and so they could originate from another source.

For LDPE, only Tenax tubes were used and relatively low concentrations of a limited range of chemical species were observed. With this material the opportunity was taken to obtain more than one background measurement in order to obtain a fuller characterization. Unlike certain other situations purging was not found to increase significantly the concentrations of species detected for this process. This was corroborated by the effect seen at the time where it was apparent that little or no enhancement either in the amount of visual fume or in process odour resulted from carrying out the purge operation.

Both of these situations demonstrated that the relationship between the species detected near the process itself and those found in the background is complex.

#### (8) Styrene acrylonitrile (SAN)

A very limited study of this material was carried out, with only the concentration of hydrogen cyanide in the process fume being determined.

Spot measurements were taken using Draeger tubes both during standard

Table 12. Emissions data obtained on PVC during a cable extrusion process using Tenax and Poropak

PVC—cable extrusion Adsorbents, Tenax and Poropak Melt temperature, 140°C (standard conditions), 180°C (purging)						
Tube 1 static machine/operator (1)—Tenax						
Tube 2 static machine/operator (2)—Tenax						
Tube 3 static machine/operator* (purging)—Tenax						
Tube 4 static background—Tenax 1						
Tube 5 static background—Tenax 2						
Tube 6 static machine/operator (2)—Poropak						
Compound	Concentration					
	Tube 1 (mg m <sup>-3</sup> )	Tube 2 (mg m <sup>-3</sup> )	Tube 3 (mg m <sup>-3</sup> )	Tube 4 (mg m <sup>-3</sup> )	Tube 5 (mg m <sup>-3</sup> )	Tube 6 (mg m <sup>-3</sup> )
1,1,1 Trichloroethane	0.02	0.01	0.02	0.01	0.01	0.03
Toluene	0.18	0.01	0.03	0.10	0.04	0.01
Xylene isomers	0.03	0.01	0.32	0.02	0.02	0.04
Hydrocarbon (~C <sub>8</sub> -C <sub>10</sub> )	0.57	0.03	0.17	0.31	0.21	0.22
Benzene, trimethyl isomers	0.05	0.01	<0.01	0.05	0.05	0.05
Benzene, ethyldimethyl isomer	0.01	<0.01	0.05	<0.01	<0.01	<0.01
Hydrocarbon (~C <sub>9</sub> -C <sub>11</sub> )	0.43	0.17	1.00	0.28	0.44	0.64
Hydrocarbon (~C <sub>10</sub> -C <sub>12</sub> )	0.09	0.04	0.99	0.05	0.07	0.03
Hydrocarbon (~C <sub>11</sub> -C <sub>13</sub> )	<0.01	<0.01	0.96	0.04	<0.01	0.07

\*Different extrusion line.

Table 13. Emissions data obtained on a LDPE-LLDPE blend during a blown film process using Tenax

LDPE-LLDPE—blown film			
Adsorbent, Tenax; Melt temperature, 190°C			
Tube 1 static—machine			
Tube 2 static—operator			
Tube 3 static—background			
Compound	Concentration		
	Tube 1 (mg m <sup>-3</sup> )	Tube 2 (mg m <sup>-3</sup> )	Tube 3 (mg m <sup>-3</sup> )
Hexane	<0.1	nd	0.14
Hydrocarbon (~C <sub>6</sub> )	<0.1	0.15	<0.1
Xylene isomer	<0.1	0.12	0.12
a-Methyl styrene	0.89	1.16	1.11
Benzene, trimethyl isomer	0.16	0.13	0.13
Hydrocarbon (~C <sub>10</sub> -C <sub>12</sub> )	3.93	2.16	3.14
Benzene, trimethyl isomer	0.31	<0.1	<0.1
Benzene, ethyl, dimethyl isomer	<0.1	0.12	<0.1
Aliphatic aldehyde (~C <sub>10</sub> )	0.32	0.34	0.30
Benzene, dimethyl, pentyl isomer	0.12	<0.1	nd
Aliphatic aldehyde (~C <sub>11</sub> )	0.69	0.39	nd
Hydrocarbon (~C <sub>11</sub> -C <sub>13</sub> )	0.50	0.23	1.61
Aliphatic aldehyde (~C <sub>12</sub> )	0.12	nd	nd
Hydrocarbon (~C <sub>12</sub> -C <sub>14</sub> )	0.10	0.10	0.90

nd = not detected.

Table 14. Emissions data obtained on a LDPE-LLDPE blend during a blown film process using Chromosorb

LDPE-LLDPE—blown film			
Adsorbent, Chromosorb; Melt temperature, 190°C			
Tube 1 static—machine			
Tube 2 static—operator			
Tube 3 static—background			
Compound	Concentration		
	Tube 1 (mg m <sup>-3</sup> )	Tube 2 (mg m <sup>-3</sup> )	Tube 3 (mg m <sup>-3</sup> )
Acetone	<0.1	0.12	nd
Hydrocarbon (~C <sub>6</sub> -C <sub>8</sub> )	0.77	1.29	0.13
Unknown	0.12	0.21	<0.1
Methyl methacrylate	<0.1	0.20	nd
Styrene	<0.1	0.14	nd
Xylene isomer	0.14	0.38	nd
Hydrocarbon (~C <sub>9</sub> -C <sub>12</sub> )	2.31	2.10	<0.1
Benzaldehyde	0.21	0.47	nd
a-Methyl styrene	0.59	0.45	nd
Benzene, trimethyl isomer	0.17	nd	nd
Acetophenone	0.59	1.02	nd
Benzene, methyl, propyl isomer	0.10	nd	nd

nd = not detected.

Table 15. Emissions data obtained on LDPE during a blown film process using Tenax

Compound	LDPE—blown film Adsorbent, Tenax Melt temperature, 180°C							
	Tube 1 (mg m <sup>-3</sup> )	Tube 2 (mg m <sup>-3</sup> )	Tube 3 (mg m <sup>-3</sup> )	Concentration		Tube 6 (mg m <sup>-3</sup> )	Tube 7 (mg m <sup>-3</sup> )	Tube 8 (mg m <sup>-3</sup> )
				Tube 4 (mg m <sup>-3</sup> )	Tube 5 (mg m <sup>-3</sup> )			
Tube 1 operator—Tenax 1								
Tube 2 operator—Tenax 2								
Tube 3 static machine—Tenax 1								
Tube 4 static machine—Tenax 2								
Tube 5 static background (1)—Tenax 1								
Tube 6 static background (1)—Tenax 2								
Tube 7 static background (2)—Tenax								
Tube 8 static machine (purging)—Tenax								
Hydrocarbon (~C <sub>5</sub> )	0.01	0.01	<0.01	nd	nd	0.01	0.01	0.03
Trichloromethane	0.01	0.01	<0.01	<0.01	nd	0.01	0.01	0.01
1,1,1 Trichloroethane	0.01	<0.01	<0.01	<0.01	nd	<0.01	<0.01	<0.01
Hydrocarbon (~C <sub>6</sub> -C <sub>8</sub> )	0.01	<0.01	<0.01	<0.01	nd	<0.01	<0.01	<0.01
Toluene	0.11	0.07	0.01	0.01	<0.01	0.01	0.01	0.01
Hydrocarbon (~C <sub>9</sub> -C <sub>11</sub> )	0.02	0.03	0.02	<0.01	<0.01	0.01	0.03	0.02
Xylene isomer	0.01	0.01	<0.01	<0.01	<0.01	<0.01	<0.01	<0.01
Hydrocarbon (~C <sub>10</sub> -C <sub>12</sub> )	0.01	0.01	<0.01	<0.01	<0.01	<0.01	0.01	0.02
Hydrocarbon (~C <sub>11</sub> -C <sub>13</sub> )	<0.01	0.02	<0.01	<0.01	<0.01	<0.01	<0.01	0.01

nd = not detected.

operating conditions and during purging. The measurements in standard conditions were taken in the region that the operator occupied (approximately 1.5–2 m from the nozzle). During purging measurements were taken 10–15 cm above the purge waste and in the same operator position as that used during normal operation. In neither instance was it possible to detect hydrogen cyanide above the detection limit of the tubes (2 ppm).

Direct analysis by ion chromatography of the contents of the sampling bubblers did not result in any peaks being found at an elution time which corresponded to the cyanide ion. No hydrogen cyanide was detectable by this method, the detection limit of which was calculated as being approximately 0.5 ppm of the airborne species.

### CONCLUSIONS

The conclusions that can be drawn from this study are:

- (a) none of the situations studied were found to generate a high level of process fume. All the individual chemical species detected, were found to be present at concentrations significantly below the corresponding present occupational exposure limits (where such limits exist), even during purging operations.
- (b) In general, a higher level of emissions is generated by extrusion-based processes than by those involving injection moulding.
- (c) Purging operations result in concentrations of species higher than those generated in standard processing conditions and can also effect the type of species found.
- (d) The position that monitoring is carried out relative to the process being studied can have a significant effect on the results obtained. However, in many situations the background concentrations of volatiles was found to be similar to those found in monitoring positions very close to the process.
- (e) The use of thermal desorption with gas chromatography–mass spectrometry (GC–MS) analysis has been shown to be an effective technique for the study of thermoplastic fume. Some advantages over solvent desorption, particularly with regard to sensitivity, have been demonstrated.
- (f) Tenax has been shown to be a satisfactory general purpose adsorbent material for this type of study, with Chromosorb and Poropak possibly offering some advantages within the low molecular weight–high volatility region (e.g. the HIPS injection moulding data).

### REFERENCES

- Edgerley, P. G. (1980) *Plastics and Rubber Institute, Health and Safety in the Plastics and Rubber Industries, Conference, Warwick*, pp. 11.1–11.10.
- Hoff, A. and Jacobsson, S. (1981) Thermo-oxidative degradation of low-density polyethylene close to industrial processing conditions. *J. Appl. Polymer Sci.* **26**, 3409–3423.
- Hoff, A., Jacobsson, S., Pfaffli, P., Zitting A. and Frostling, H. (1982) Degradation products of plastics—polyethylene and styrene containing thermoplastics—analytical, occupational and toxicological aspects. *Scand. J. Wk Environ. Hlth* **8**, Supplement 2, 1–60.
- HSE (1987) MDHS 60. Mixed hydrocarbons (C<sub>3</sub> to C<sub>10</sub>) in air. Health and Safety Executive. HMSO, London.
- HSE (1989) MDHS 66. Mixed hydrocarbons (C<sub>5</sub> to C<sub>10</sub>) in air. Health and Safety Executive. HMSO, London.
- HSE (1992) MDHS 72. Volatile organic compounds in air. Health and Safety Executive. HMSO, London.

- Lemmen, T. H., Conroy, G. M. and Bautista, P. A. (1989) Odor and PVC: Identification and quantification of volatiles in clear polyvinylchloride processing. *J. Vinyl Technol.* **11**, 133-136.
- Lum, R. M. and Kelleher, P. G. (1979) *Polym. Preprints* **20**, No. 2, 608-613.
- Shaposhnikov, Yu. K., Kisarov, V. M., Saltanova, V. B., Novokovskaya, M. I. and Kirillova, E. I. (1975) Determination of volatile products in processing of polypropylene, PVC and ABS plastics *Plast. Massy.* No. 5, 37-38.
- Shmuilovich, S. M., Konstantinova, E. I. and Lazaris, A. Ya. (1981) Study of gaseous emissions from PVC resins. *Plast. Massy.* No.6, 48-49.
- Vainiotalo, S. and Pfaffli, P. (1989) Measurement of depolymerisation products in the polyacetal, polyamide and polymethyl methacrylate industry. *Am. ind. Hyg. Ass. J.* **50**, 396-399.
- Williamson, J. and Kavanagh, B. (1987) Vinyl chloride monomer and other contaminants in PVC welding fumes. *Am. ind. Hyg. Ass. J.* **48**, 432-436.

BEFORE THE ILLINOIS POLLUTION CONTROL BOARD

ORIGINAL

RECEIVED  
CLERK'S OFFICE

IN THE MATTER OF:

JUN 16 2005

PROPOSED AMENDMENTS TO )  
EXEMPTIONS FROM STATE )  
PERMITTING REQUIREMENTS )  
FOR PLASTIC INJECTION MOLDING )  
OPERATIONS )  
(35 Ill. Admin. Code 201.146) )

STATE OF ILLINOIS  
Pollution Control Board

R 05 -20

**PRE-FILED TESTIMONY OF PATRICIA F. SHARKEY  
ON BEHALF OF THE  
CHEMICAL INDUSTRY COUNCIL OF ILLINOIS**

My name is Patricia F. Sharkey and I am an attorney with the law firm of Mayer, Brown Rowe & Maw representing the Chemical Industry Council of Illinois in this proceeding. I am testifying in this proceeding for the limited purpose of providing the Board with publicly available information derived from our legal research pertaining to other states' permit exemptions for plastic injection molding operations.

While we have not done an exhaustive search of all 50 state's regulations, we can say that plastic injection molding operations are expressly exempted from state air pollution control permitting by a number of states, including Michigan, Ohio and Texas..

The amendatory language proposed by CICI in this proceeding was based on the permit exemption language contained in the Michigan Department of Environmental Quality's ("MDEQ") regulations which states:

"Rule 286. The requirement of R336.1201(1) to obtain a permit to install does not apply to any of the following:

- ...
- (b) Plastic injection, compression, and transfer molding equipment and associated plastic resin, handling, storage, and drying equipment."

The Texas Administrative Code, Title 30, Part I, Chap. 106,

Subchapter Q, Rule 106.394 is even briefer, simply stating:

“Equipment used for compression molding and injection molding of plastics is permitted by rule.”

Ohio Administrative Code 3745-31-03(A)(1)(k) creates a “permanent exemption” from state permits to install for:

“Equipment used for injection molding of resins where no more than one million pounds of resins (thermoplastic or thermosetting) per rolling twelve-month period are used in injection machines at the facility.”

The Ohio rules also provide for a discretionary exemption for equipment used for injection molding of resin where the facility does not qualify for the exemption under paragraph (A)(1)(k) and “the facility uses no thermoset resins and no more than six million pounds of thermoplastic resins (e.g., polyethylene, polypropylene, polycarbonate, and polyvinyl chloride, etc.) per rolling twelve-month period in injection machines at the facility.”

Copies of the Michigan, Ohio, and Texas regulations are attached hereto as Exhibits 1 through 3 respectively. Iowa is also considering such an exemption. See attached announcement. Exhibit 4.

PIM operations are also effectively exempted in many other states by virtue of the fact that the level of emissions attributable to PIM operations and/or PIM facilities fall beneath *de minimis* emission exemption levels contained in those states regulations *and* such exemptions are not limited emission units at otherwise permitted facilities. Examples of



states with such *de minimis* exemptions include the other Region 5 U.S. EPA states:

Wisconsin, Indiana, and Minnesota.

Indiana employs a tiered system in which only emissions units with a potential to emit (PTE) of 25 tons per year are required to obtain full state construction and operating permits. Units with a PTE of 10 to 25 tons are required to be registered with IDEM, but do not require permits.

Section 2-1.1-3(d)(4)(e)(1) of the IDEM regulations *exempts from both minor source permitting and registration* any new emission unit or modification at the following PTE levels:

- 1) 10 tons per year of PM<sub>10</sub>, SO<sub>2</sub>, NO<sub>x</sub> or VOC,
- 2) 5 tons of PM, hydrogen sulfide, total reduced sulfur, reduced sulfur compounds, fluorides, or VOC, if the unit is required to use of air pollution control equipment to comply with the applicable VOC provisions;
- 3) 25 tons of CO;
- 4) 2/10ths of a ton of lead; and
- 5) 1 ton of any hazardous air pollutant (HAP).

Chapter 7007 of the Minnesota Pollution Control Agency's (MPCA) regulations governs air permitting in Minnesota.. Under Part 7007.1300(3)(I) emission units with a PTE of less than the following levels qualify as "insignificant activities" and are exempt from permit requirements:

- 1) 2 tons per year of CO, and
- 2) 1 ton per year of NO<sub>x</sub>, SO<sub>2</sub>, PM, PM-10, VOC (including hazardous air pollutant-containing VOCs).

Wisconsin

In Wisconsin, Section 406.03 (1) of the Wisconsin Department of Natural Resources' air pollution control regulations states that no construction permit is required prior to

commencing “construction, reconstruction, replacement, relocation or modification” of certain specified categories of equipment, activities and operations. Section 406.03(2) states that, in addition to the categorical exemptions, no construction permit is required if the maximum theoretical emissions from the source, meaning the *facility as a whole*, do not exceed any of the following levels:

- 1) 9.0 lbs per hour for SO<sub>2</sub> and CO ( which translates to ~40 tons per year);
- 2) 5.7 lbs per hour for PM, NO<sub>x</sub> or VOC ( which translates to ~25 tons per year);
- 3) 3.4 lbs per hour for PM<sub>10</sub> ( which translates to ~15 tons per year);
- 4) 0.13 lbs per hour for lead ( which translates to ~1 ton per year); and
- 5) various emission rates listed for specified hazardous air contaminants.

Our point in referencing these other states regulations is to provide the Board with some perspective on the exemption CICI is proposing in this proceeding. PIM machines with the potential to emit in the range of 0.0022 to 0.22 tons per year of VOM, 0.00022 and 0.18 tons per year of HAPs and 0.0088 to 0.088 tons of PM per year, under conservative assumptions, are very minor emission sources. In recognition of this fact, state permitting is not required for these machines in many other states, including Illinois neighboring states in U.S. EPA Region 5.

While CICI has provided testimony on the level of emissions generated by PIM processes, it is important that the Board recognize that this proposal will not result in any increase in emissions to the environment. If exempted, PIM processes, like every other category of emission sources exempted under 35 Ill. Adm. Code 201.146, will remain subject to all applicable regulations, as expressly stated in that section:

“ ...The permitting exemptions in this Section do not relieve the owner or operator of any source from any obligation to comply with any other applicable requirements, including the obligation to obtain a

permit pursuant to Sections 9.1(d) and 39.5 of the Act, Sections 165, 173, and 502 of the Clean Air Act or any other applicable permit or registration requirements.”

On behalf of CICI, I would like to thank the Board for its consideration of this testimony and this proposed exemption and would be happy to respond to any questions the Board or other members of the interested public may have.

Respectfully submitted,

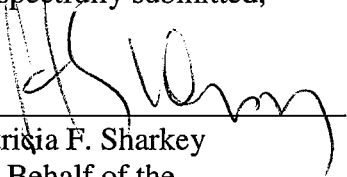

Patricia F. Sharkey  
On Behalf of the  
Chemical Industry Council of Illinois

## Exhibit 1

### MICHIGAN DEQ

#### **R 336.1286 Permit to install exemptions; plastic processing equipment.**

Rule 286. The requirement of R 336.1201(1) to obtain a permit to install does not apply to any of the following:

- (a) Plastic extrusion, rotocasting, and pultrusion equipment and associated plastic resin handling, storage, and drying equipment.
- (b) Plastic injection, compression, and transfer molding equipment and associated plastic resin handling, storage, and drying equipment.
- (c) Plastic blow molding equipment and associated plastic resin handling, storage, and drying equipment if the blowing gas is 1 or more of the following gasses:
  - (i) Air.
  - (ii) Nitrogen.
  - (iii) Oxygen.
  - (iv) Carbon dioxide.
  - (v) Helium.
  - (vi) Neon.
  - (vii) Argon.
  - (viii) Krypton.
  - (ix) Xenon.
- (d) Plastic thermoforming equipment.
- (e) Reaction injection molding (open or closed mold) and slabstock/casting equipment.

*History: 1993 MR 11, Eff. Nov. 18, 1993; 1995 MR 7, Eff. July 26, 1995; 1997 MR 5, Eff. June 15, 1997.*

## Exhibit 2

### OHIO EPA

#### 3745-31-03 Permit to install exemptions.

(A) A permit to install as required by rule 3745-31-02 of the Administrative Code must be obtained for the installation or modification of a new air contaminant source unless exempted from the requirements as follows:

(1) Permanent exemptions:

The following exemptions do not apply to a combination of common emissions units that are a major stationary source or major modification, or to emissions units that the National Emissions Standards for Hazardous Air Pollutants applies (except for 40 CFR Part 61, subpart M, asbestos removal activities), or to emissions units that the Maximum Achievable Control Technology standard applies, or to emissions units that the "New Source Performance Standards" applies (except for 40 CFR Part 60, subpart AAA, residential wood heaters).

...

(k) Equipment used for injection molding of resins where no more than one million pounds of resins (thermoplastic or thermosetting) per rolling twelvemonth period are used in injection machines at the facility.

...

(m) Compression molding presses used for the curing of plastic products that qualify for the de minimis exemption under rule 3745-15-05 of the Administrative Code. This type of press uses a thermosetting resin and involves a chemical reaction, usually involving heat, that converts the material (e.g., polyesters, polyurethanes, epoxy resins, etc.) to a solid, insoluble state using a hardening or curing operation.

...

(4) Permit-by-rule exemptions

The following air contaminant sources are exempt from the requirement to obtain a permit to install. These exemptions are valid only as long as the owner or operator collects and maintains the records described for each air contaminant source exempted under this rule and these records are retained in the owner or operator's files for a period of not less than five years and are made available to the director or any authorized representative of the director for review during normal business hours:

...

(b) Equipment used for injection and compression molding of resins where:

(i) The facility does not qualify for the exemption under paragraph (A)(1)(k) or (A)(1)(m) of rule 3745-31-03 of the Administrative Code; and

(ii) The facility uses no more than 1000 pounds of volatile organic compound in external mold release agents and flatting spray per rolling

twelve-month period; and

- (a) The facility uses no thermoset resins and no more than six million pounds of thermoplastic resins (e.g., polyethylene, polypropylene, polycarbonate, and polyvinyl chloride, etc.) per rolling twelve-month period in injection machines at the facility (this type of molding operation involves materials that soften and melt upon heating or pressurization heating with no chemical change and no permanent change in physical properties. It does not involve curing, thermosetting or cross-linking.); or
- (b) The facility uses no thermoplastic resins and no more than five hundred thousand pounds of thermoset resins (e.g., polyesters, polyurethanes, epoxy resins, etc.) per rolling twelve-month period in injection and compression molding machines at the facility (these types of molding operations use a thermoset resin and involve a chemical reaction, usually involving heat, that converts the material (e.g., polyesters, polyurethanes, epoxy resins, etc.) to a solid, insoluble state using a hardening or curing operation.); or
- (iii) No more than three tons per year of volatile organic compounds are emitted, including volatile organic compounds from external mold release agents and flatting spray, per rolling twelve-month period from injection and compression molding machines at the facility calculated by using emission factors approved by the Ohio EPA; and
- (iv) The facility maintains monthly records that contain the rolling twelve-month usage of thermoplastic resins, thermosetting resins and volatile organic compounds in external mold release agents and flatting spray used in all injection and compression molding machines at the facility, and the Ohio EPA approved emission factors used to calculate the emissions.

[<<Prev Rule](#)

# Texas Administrative Code

[Next Rule>>](#)

**TITLE 30**

ENVIRONMENTAL QUALITY

**PART 1**

TEXAS COMMISSION ON ENVIRONMENTAL QUALITY

**CHAPTER 106**

PERMITS BY RULE

**SUBCHAPTER Q**

PLASTICS AND RUBBER

**RULE §106.394**

**Plastic Compression and Injection Molding**

Equipment used for compression molding and injection molding of plastics is permitted by rule.

**Source Note:** The provisions of this §106.394 adopted to be effective March 14, 1997, 22 TexReg 2439; amended to be effective September 4, 2000, 25 TexReg 8653

[Next Page](#)

[Previous Page](#)

[List of Titles](#)

[Back to List](#)

[HOME](#) | [TEXAS REGISTER](#) | [TEXAS ADMINISTRATIVE CODE](#) | [OPEN MEETINGS](#) | [HELP](#) |

**Update on "Indoor Sources" and "Permit it or Exempt it" statement  
January 18, 2005**

The Iowa Department of Natural Resources (IDNR) is formally withdrawing the "Permit it or Exempt it" statement ("Requirements for Small Source Permitting and Exemptions," revision date August 5, 2004). IDNR will resume its past practice of only requiring permits for indoor sources when needed to limit the facility's potential emissions to reduce its regulatory burden (when those units were required to be permitted due to major source permitting requirements), or if the IDNR believes that the facility is trying to circumvent permitting requirements.

IDNR, company representatives, the Iowa Department of Economic Development (IDED), University of Northern Iowa (UNI) Emissions Assistance Program, and the U.S. Environmental Protection Agency Region 7, met in a Work Group on January 10 to 12, 2005, to develop a new plan for addressing air pollution sources whose emissions are not directly vented to the outside (also known as "indoor" sources). This new plan includes:

1. Withdrawing the "Permit it or Exempt it" statement and its February 28, 2005 implementation deadline and in its place resuming the Department's past practice for the regulatory treatment of these sources,
2. Pursuing EPA approval for DNR's past practice of only requiring permits for indoor sources when as mentioned above this is needed to either limit a facility's potential emissions to reduce its regulatory burden, or if the Department believes a facility is trying to circumvent permitting requirements,
3. Allowing the use of exemptions currently in DNR administrative rule to be available for sources which are covered under a MACT, NESHAPS or NSPS or other applicable federal standard,
4. Adopting a list of "trivial" activities not needing a permit into DNR's administrative rules, and
5. Developing a more extensive list of exemptions from the requirement to get construction permits. These exemptions will be proposed in two rulemakings.

The Work Group is completing development of draft administrative rules to exempt 11 activities or equipment types from air construction permitting. These exemptions will have thresholds necessary to assure protection of air quality. The first set of exemptions will be introduced to the Environmental Protection Commission (EPC) in March 2005. DNR will also include a list of "Trivial Activities" for which permits are not required. To provide industry and the public with an opportunity to help develop these rules, a first draft of the rules will be posted on the DNR website ([www.iowacleanair.com](http://www.iowacleanair.com)), and distributed through the "Air-tech" list server February 17<sup>th</sup>, 2005.



The WorkGroup will consider comments sent to the Department before the rule is taken back to the EPC on April 2005 for formal consideration and public comment. Final action on the rule is expected in July, 2005. Each of the activities listed below will be addressed in the first rulemaking. However, these exemptions will not apply to all sizes and types of this equipment, except to the extent that an adequate justification for rulemaking can be developed. Those under development include:

1. Welding and brazing,
2. Storage & mixing of flammable materials,
3. Powder coating operations,
4. Conveying of wet grain,
5. Research and development,
6. Saw Dust with pollution control,
7. Spray aerosols,
8. Direct fired heating,
9. Phosphatizing,
10. Pressurized storage tanks, and
11. Refrigeration systems.

“Trivial Activities” include the following:

1. Cafeterias, kitchens, and other facilities used for preparing food or beverages primarily for consumption at the source.
2. Consumer use of office equipment and products, not including printers or businesses primarily involved in photographic reproduction.
3. Janitorial services and consumer use of janitorial products.
4. Internal combustion engines used for lawn care, landscaping, and grounds-keeping purposes.
5. Laundry activities, not including dry-cleaning and steam boilers.
6. Bathroom vent emissions, including toilet vent emissions.
7. Blacksmith forges.
8. Plant maintenance and upkeep activities, and repair or maintenance shop activities (e.g., grounds-keeping, general repairs, cleaning, painting, welding, plumbing, re-tarring roofs, installing insulation, and paving parking lots) provided these activities are not conducted as part of a manufacturing process, are not related to the source's primary business activity, and not otherwise triggering a permit modification. Cleaning and painting activities qualify if they are not subject to VOC or HAP control requirements.
9. Air compressors and vacuum pumps, including hand tools.
10. Batteries and battery charging stations, except at battery manufacturing plants.
11. Storage tanks, reservoirs, pumping and handling equipment of any size, and equipment used to mix and package soaps, detergents, surfactants, waxes, glycerin, vegetable oils, greases, animal fats, sweetener, corn syrup, and aqueous salt or caustic solutions, provided appropriate lids and covers are utilized and no organic solvent has been mixed with such materials.

12. Equipment used exclusively to slaughter animals, but not including other equipment at slaughterhouses, such as rendering cookers, boilers, heating plants, incinerators, and electrical power generating equipment.
13. Vents from continuous emissions monitors and other analyzers.
14. Natural gas pressure regulator vents, excluding venting at oil and gas production facilities.
15. Equipment used for surface coating by brush or roller, painting, and dipping operations, except those that will emit VOC or HAP.
16. Hydraulic and hydrostatic testing equipment.
17. Environmental chambers not using HAP gasses.
18. Shock chambers and humidity chambers, and solar simulators.
19. Fugitive dust emissions related to movement of passenger vehicles on unpaved road surfaces, provided the emissions are not counted for applicability purposes and any fugitive dust control plan or its equivalent is submitted as required by the department.
20. Process water filtration systems and demineralizers, demineralized water tanks, and demineralizer vents.
21. Boiler water treatment operations, not including cooling towers.
22. Oxygen scavenging (de-aeration) of water.
23. Fire suppression systems.
24. Emergency road flares.
25. Steam vents and safety relief valves, steam leaks, and steam sterilizers.
26. Steam sterilizers.
27. Recycling centers.

The workgroup will meet again in July 2005 to prepare technical justifications to support a second exemption rulemaking. The following equipment, activities, and processes have been suggested to be considered for the second exemption rulemaking:

Product labeling, coating operations, aqueous cleaning systems, small parts washers, steam cleaning, small electric heat transfer furnaces, laser, electric, plasma, and gaseous fuel cutting, dry cleaners, cooling towers, polymer mixing, plastic injection molders, spray application of water based glue, hand held applicators for hot metal adhesive, equipment for used for surface coating, ozone generators, salt baths, drop hammers, extruders, wet grain and coke products handling, spray aerosols and trigger sprayers used for cleaning, pressurized refrigerant storage tanks, paved roads, and possible vehicle maintenance activities.

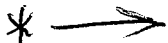

If you would like additional information on this please contact the following individuals at the DNR: Jim McGraw, Supervisor, Air Quality Bureau at 515/242-5167 or Christine Spackman, Business Assistance Coordinator at 515/281-7276.